



This deliverable has not yet been externally reviewed and approved by the European Commission.

Project no.:	101095738		
Project full title:	6G SHort range extreme communication IN Entities		
Project Acronym:	6G-SHINE		
Project start date:	01/03/2023	Duration	30 months

D2.2. – REFINED DEFINITION OF SCENARIOS, USE CASES AND SERVICE REQUIREMENTS FOR IN-X SUBNETWORKS

Due date	29/02/2024	Delivery date	28/02/2024
Work package	WP2		
Responsible Author(s)	Basuki Priyanto (SONY)		
Contributor(s)	Gilberto Berardinelli (AAU), Mathias Holst Ramlov (AAU), Baldomero Coll-Perales (UMH), Luca Lusvarghi (UMH), Keyvan Aghababaiyan (UMH), Javier Gozalvez Sempere (UMH), Miguel Sepulcre Ribes (UMH), Naoki Kusashima (SONY), Bernhard Raaf (Apple), Sabine Roessel (Apple), Pedro Maia de Sant Ana (BOSCH), Henrik Klessig (BOSCH), Meng Li (IMEC), Fotis Foukalas (COGN)		
Version	V1.0		
Reviewer(s)	Davide Dardari (CNIT) Ognen Ognenoski (IDC)		
Dissemination level	Public		

VERSION AND AMENDMENT HISTORY

Version	Date (DD/MM/YYYY)	Created/Amended by	Changes
V0.3	15/11/2023	Basuki Priyanto	Initial version
V0.6	22/01/2024	Basuki Priyanto	Internal Review Version 1
V0.7	30/01/2024	Basuki Priyanto	Internal Review Version 2
V0.75	16/02/2024	Basuki Priyanto	Internal Review Version 3
V0.8	26/02/2024	Basuki Priyanto	Refinement and add new measurement results
V1.0	28/02/2024	Basuki Priyanto	Final version

TABLE OF CONTENTS

FIGURES	9
TABLES	11
ABBREVIATIONS	13
EXECUTIVE SUMMARY	16
1 INTRODUCTION	18
1.1 OBJECTIVE OF THE DOCUMENT	18
1.2 STRUCTURE OF THE DOCUMENT	18
1.3 METHODOLOGY	18
1.3.1 Defining Use Cases	18
1.3.2 Definition of Key Performance Indicators	19
1.3.3 Definition of Key Value Indicators	21
2 IN-X SUBNETWORK ARCHITECTURE	26
2.1 INTRODUCTION	26
2.2 NETWORK ELEMENTS OF THE PARENT NETWORK	26
2.2.1 6G Base Station (6G BS)	26
2.2.2 6G Core Network (6G CN)	26
2.2.3 6G Network Compute Node (CompN)	27
2.2.4 User Equipment (UE)	27
2.3 ELEMENTS IN A SUBNETWORK	27
2.3.1 Element with High Capabilities (HC)	27
2.3.2 Element with Low Capabilities (LC)	28
2.3.3 Subnetwork Element (SNE)	28
2.3.4 Reconfigurable Intelligent Surfaces (RIS)	28
2.4 FURTHER DEFINITIONS	29
2.4.1 Entity (EN)	29
2.4.2 In-X Wireless Subnetwork (SN)	29
2.5 ELEMENT ROLES	30
2.5.1 The Gateway (GW) Role	30
2.5.2 The Compute Offloading (OFF) Role	30
2.5.3 The Radio Resource Management (RRM) Role	30
2.5.4 The Subnetwork Management (SNM) Role	30
2.6 REFERENCE ARCHITECTURE	31

2.7	COMMUNICATION MODES	32
2.8	GENERAL HINTS ON FUNCTIONAL REQUIREMENTS	34
3	CONSUMER SUBNETWORKS CATEGORY	36
3.1	STATUS QUO ON CONSUMER NETWORKS	36
3.2	EVOLUTION TRENDS	37
3.3	BENEFITS AND CHALLENGES OF CONSUMER SUBNETWORKS	37
3.4	KVIs OF CONSUMER SUBNETWORKS	38
3.5	CONSUMER SUBNETWORKS USE CASES	39
3.5.1	Immersive Education.....	40
3.5.1.1	Description	40
3.5.1.2	Pre-condition(s).....	41
3.5.1.3	Operation Flow.....	41
3.5.1.4	Deployment Scenarios	42
3.5.1.5	Subnetwork Architecture	42
3.5.1.6	Post-condition(s)	44
3.5.1.7	Challenges to the 6G system	44
3.5.1.8	Traffic Characteristics	46
3.5.1.9	KPI Aspects & Requirements.....	46
3.5.2	Indoor Interactive Gaming.....	48
3.5.2.1	Description	48
3.5.2.2	Pre-condition(s).....	49
3.5.2.3	Operation Flow.....	49
3.5.2.4	Deployment Scenarios	49
3.5.2.5	Subnetwork Architecture	50
3.5.2.6	Post-condition(s)	51
3.5.2.7	Challenges to the 6G system	52
3.5.2.8	Traffic Characteristics	52
3.5.2.9	KPI Aspects & Requirements.....	54
3.5.3	Virtual content production of live music.....	56
3.5.3.1	Descriptions	56
3.5.3.2	Pre-condition(s).....	57
3.5.3.3	Operation Flow.....	57
3.5.3.4	Deployment Scenarios	57
3.5.3.5	Subnetwork Architecture	58

3.5.3.6	Post-condition(s)	59
3.5.3.7	Challenges to the 6G system	59
3.5.3.8	KPI Aspects & Requirements	60
3.5.4	Augmented Reality (AR) Navigation	61
3.5.4.1	Descriptions	61
3.5.4.2	Pre-condition(s).....	62
3.5.4.3	Operation Flow.....	62
3.5.4.4	Deployment Scenarios	63
3.5.4.5	Subnetwork Architecture	63
3.5.4.6	Post-condition(s)	64
3.5.4.7	Challenges to the 6G system	64
3.5.4.8	KPI Aspects.....	66
3.6	6G CHALLENGES AND 6G-SHINE TECHNOLOGY COMPONENTS RELATED TO CONSUMER SUBNETWORK	66
4	INDUSTRIAL SUBNETWORKS CATEGORY	69
4.1	STATUS QUO ON INDUSTRIAL NETWORKS	69
4.2	SWARM PRODUCTION AS A TREND AND THE ROLE OF 6G SUBNETWORKS	70
4.3	BENEFITS AND CHALLENGES OF INDUSTRIAL SUBNETWORKS	71
4.4	KVIS OF INDUSTRIAL SUBNETWORKS.....	72
4.5	INDUSTRIAL SUBNETWORKS USE CASES.....	73
4.5.1	Robot Control	73
4.5.1.1	Description	73
4.5.1.2	Pre-condition(s).....	74
4.5.1.3	Operation Flow.....	74
4.5.1.4	Deployment Scenarios	75
4.5.1.5	Subnetwork Architecture	75
4.5.1.6	Post-condition(s)	76
4.5.1.7	KPI Aspects & Potential Requirements	76
4.5.2	Unit Test Cell.....	77
4.5.2.1	Description	77
4.5.2.2	Pre-condition(s).....	77
4.5.2.3	Operation Flow.....	78
4.5.2.4	Deployment Scenarios	78
4.5.2.5	Subnetwork Architecture	79

4.5.2.6	Post-condition(s)	80
4.5.2.7	KPI Aspects & Potential Requirements	80
4.5.3	Visual Inspection Cell	80
4.5.3.1	Description	80
4.5.3.2	Pre-condition(s)	80
4.5.3.3	Operation Flow	81
4.5.3.4	Deployment Scenarios	82
4.5.3.5	Subnetwork Architecture	82
4.5.3.6	Post-condition(s)	83
4.5.3.7	KPI Aspects & Potential Requirements	83
4.5.4	Subnetworks Swarms: Subnetwork Co-existence in Factory Hall	85
4.5.4.1	Description	85
4.5.4.2	Pre-condition(s)	86
4.5.4.3	Operation Flow	87
4.5.4.4	Deployment Scenarios	88
4.5.4.5	Subnetwork Architecture	88
4.5.4.6	Post-condition(s)	89
4.5.4.7	KPI Aspects & Potential Requirements	90
4.5.5	Subnetwork Segmentation and Management	90
4.5.5.1	Description	90
4.5.5.2	Pre-condition(s)	91
4.5.5.3	Operation Flow	91
4.5.5.4	Deployment Scenarios	92
4.5.5.5	Post-condition(s)	92
4.5.5.6	KPI Aspects & Potential Requirements	92
4.6	CHARACTERIZATION OF INDUSTRIAL TRAFFIC	93
4.7	POSSIBLE INDUSTRIAL SUB-CATEGORIES	98
4.8	6G CHALLENGES AND 6G-SHINE TECHNOLOGY COMPONENTS RELATED TO INDUSTRIAL SUBNETWORK	99
5	IN-VEHICLE SUBNETWORKS CATEGORY	101
5.1	STATUS QUO ON IN-VEHICLE NETWORKS AND E/E ARCHITECTURES	101
5.2	IN-VEHICLE EVOLUTIONARY TRENDS	102
5.3	6G-SHINE REFERENCE IN-VEHICLE FRAMEWORK	104
5.4	BENEFITS AND CHALLENGES OF IN-VEHICLE SUBNETWORKS	105

5.5	KVIS OF IN-VEHICLE SUBNETWORKS	106
5.6	IN-VEHICLE SUBNETWORKS USE CASES	107
5.6.1	Wireless Zone ECU: In-vehicle wireless subnetwork zone	107
5.6.1.1	Description	107
5.6.1.2	Pre-condition(s)	108
5.6.1.3	Operation Flow	109
5.6.1.4	Deployment Scenarios	110
5.6.1.5	Subnetwork Architecture	110
5.6.1.6	Post-condition(s)	111
5.6.1.7	KPI Aspects & Potential Requirements	112
5.6.2	Collaborative Wireless Zone ECUs: Functions across multiple in-vehicle zones 114	
5.6.2.1	Description	114
5.6.2.2	Pre-condition(s)	114
5.6.2.3	Operation Flow	115
5.6.2.4	Deployment Scenarios	115
5.6.2.5	Subnetwork Architecture	116
5.6.2.6	Post-condition(s)	117
5.6.2.7	KPI Aspects & Potential Requirements	117
5.6.3	Inter-subnetwork Coordination: Collaboration between subnetworks in intra/inter-vehicle communications	117
5.6.3.1	Description	117
5.6.3.2	Pre-condition(s)	119
5.6.3.3	Operation Flow	120
5.6.3.4	Deployment Scenarios	120
5.6.3.5	Subnetwork Architecture	121
5.6.3.6	Post-condition(s)	122
5.6.3.7	KPI Aspects & Potential Requirements	122
5.6.4	Virtual ECU: In-vehicle sensor data and functions processing at the 6G network edge	122
5.6.4.1	Description	122
5.6.4.2	Pre-condition(s)	124
5.6.4.3	Operation Flow	124
5.6.4.4	Deployment Scenarios	124
5.6.4.5	Subnetwork Architecture	124

5.6.4.6	Post-condition(s)	126
5.6.4.7	KPI Aspects & Potential Requirements	126
5.7	IN-VEHICLE NETWORK TRAFFIC CHARACTERISTICS	126
5.7.1	Connected and Automated Mobility (CAM) Research Platform	126
5.7.2	Sensor Deployment and Characteristics	129
5.7.3	Message Logging	130
5.7.4	Driving scenarios	131
5.7.5	Results	132
5.8	6G CHALLENGES AND 6G-SHINE TECHNOLOGY COMPONENTS RELATED TO IN-VEHICLE SUBNETWORK	138
6	CONCLUSIONS	142
	REFERENCES	145

FIGURES

Figure 1: Illustration of 6G-SHINE project in supporting various use cases	19
Figure 2: The 17 UN Sustainability Development Goals (SDGs) (figure taken and simplified from [5]) ..	21
Figure 3: The 17 SDGs grouped by Stockholm Resilience Centre (figure taken from [7])	22
Figure 4: Illustration the relation of KV, KVI, and KPI of a use-case.....	23
Figure 5: Reference Architecture	31
Figure 6: Example Role Assignment	32
Figure 7: Example of communication modes for the reference architecture.....	34
Figure 8: Illustration of immersive education showing some potential hierarchical subnetworks (adapted from [11])	41
Figure 9: Subnetwork Architecture of the Immersive Education Use Case	43
Figure 10: Illustration of indoor interactive gaming within a subnetwork	48
Figure 11: Subnetwork Architecture of the Indoor Interactive Gaming Use Case.....	51
Figure 12: Split Rendering Operation in Cloud Gaming	53
Figure 13: Overall Description of Content Production of Live Music.....	57
Figure 14: Subnetwork Architecture of the Virtual Live Production Use Case	58
Figure 15: Illustration of AR Navigation	62
Figure 16: Subnetwork Architecture of the AR Navigation Use Case	64
Figure 17: Illustration of the Robot Control Use Case.....	74
Figure 18: Subnetwork Architecture of the Robot Control Use Case.....	76
Figure 19: Illustration of the Unit Test Cell Use Case	78
Figure 20: Subnetwork Architecture of the Unit Test Cell Use Case.....	79
Figure 21: Illustration of the Visual Inspection Cell Use Case	81
Figure 22: Subnetwork Architecture of the Visual Inspection Cell Use Case	83
Figure 23: Illustration of the Subnetwork Co-existence in Factory Hall Use Case	86
Figure 24: Example of a pre-condition for the co-existence of two adjacent sub-networks.....	87
Figure 25: Subnetwork Architecture of the Subnet Co-existence in Factory Hall Use Case	89
Figure 26: Traffic traces (a) and distribution of inter-arrival times (b) for motion control.....	95
Figure 27: Traffic traces (a) and distribution of inter-arrival times (b) for robot control.	95
Figure 28: Traffic traces (a) and packet interarrival distribution (b) for UDP traffic generated by sensor camera.....	96

Figure 29: Time traces (a) and distribution of packet interarrival times (b) for TPC traffic generated by sensor camera. 97

Figure 30: Time traces (a) and distribution of packet interarrival times (b) for traffic generated by the second sensor camera. 97

Figure 31: Evolutionary Trends in E/E Architecture Development (figure taken from [41]) 102

Figure 32: Evolution of vehicular E/E architectures 104

Figure 33: 6G-SHINE reference in-vehicle E/E architecture that captures the evolutionary trends towards centralized, zone-oriented E/E architectures. 105

Figure 34: Wireless zone ECU 108

Figure 35: Subnetwork Architecture of the Wireless Zone ECU Use Case 111

Figure 36: Collaborative wireless zone ECUs. 114

Figure 37: Subnetwork Architecture of the Collaborative Wireless Zone ECUs Use Case 116

Figure 38: Intra-vehicular RRM within the 6G-SHINE reference E/E Architecture. 118

Figure 39: Inter-vehicular RRM between adjacent vehicles. 119

Figure 40: Subnetwork Architecture of the Inter-subnetwork Coordination Use Case 121

Figure 41: Integration of the 6G in-vehicle network with the 6G parent network. 123

Figure 42: Subnetwork Architecture of the Virtual ECU Use Case 125

Figure 43: CAM research platform for IVN traffic characterization. 128

Figure 44: CAM research platform setup with a single AUTOWARE instance. 128

Figure 45: Sensor deployment for the L3 autonomous vehicle. 130

Figure 46: AUTOWARE main functionalities and relevant ROS topics. 131

Figure 47: Driving scenarios: left: highway with vehicles driving in the same direction; center: urban with vehicles driving in opposite directions; right: intersection scenario. 132

Figure 48: Raw and processed data generated by different on-board sensor types. 133

Figure 49: Size of the radars’ processed data. 134

Figure 50: Message size at the output of the Autoware’s perception module for different driving scenarios. 135

Figure 51: Cross-correlation between the sensors’ processed data. 136

Figure 52: Cross-correlation of the processed message sizes of the radars over time. 137

Figure 53: Perception module’s processing time 138

TABLES

Table 1: Symbols of Parent Network Elements	27
Table 2: Symbols of the Elements Involved in Local Communication	28
Table 3: Symbols for Entities and Subnetworks	29
Table 4: Symbols for the Different Roles.....	30
Table 5: Possible Communication Relationships Between Elements.....	32
Table 6: Summary of KVI and its enabler of Consumer Subnetwork	39
Table 7: Functional Requirements of the Immersive Education Use Case	43
Table 8: Selected Key TCs for Immersive Education Use Case	45
Table 9: Functional Requirements of the Indoor Interactive Gaming Use Case	51
Table 10: Selected Key TCs for Indoor Interactive Gaming Use Case	52
Table 11: Functional Requirements of the Virtual Live Production Use Case.....	58
Table 12: Selected Key TCs for Virtual Content Production Use Case	59
Table 13: Functional Requirements of the AR Navigation Use Case.....	64
Table 14: Selected Key TCs for Augmented Reality (AR) Navigation	65
Table 15: Technical Components (TCs) Addressing the Consumer subnetwork Use Case Challenges	67
Table 16: Summary of KVI & Its enabler of Industrial Subnetwork Use Cases.....	72
Table 17: Functional Requirements of the Robot Control Use Case.....	76
Table 18: Functional Requirements of the Unit Test Cell Use Case	79
Table 19: Functional Requirements of the Visual Inspection Cell Use Case	83
Table 20: Summary of the main requirements of the three use cases in the Industrial category	84
Table 21: Functional Requirements of the Subnet Co-existence in Factory Hall Use Case.....	89
Table 22: Functional Requirements of the Subnetwork Segmentation and Management Use Case.....	93
Table 23: Hierarchical Setup of Industrial Sub-Categories and Use Cases.....	98
Table 24: Technical Components (TCs) Addressing the Use Case Challenges	99
Table 25: Summary of KVI & Its enabler of In-vehicle subnetwork Use Cases	107
Table 26: Functional Requirements of the Wireless Zone ECU Use Case	111
Table 27: KPIs for in-vehicle networks of the vehicle’s domain functions [48]	112
Table 28: KPIs for in-vehicle wired networking technologies [47][48]	113
Table 29: Functional Requirements of the Collaborative Wireless Zone ECUs Use Case	116

Table 30: Functional Requirements of the Inter-subnetwork Coordination Use Case	121
Table 31: Functional Requirements of the Virtual ECU Use Case	125
Table 32: Technical Components (TCs) addressing In-Vehicle category use case challenges	139
Table 33: Summary of the use cases and short descriptions	142

ABBREVIATIONS

Abbreviation	Meaning
2G	Second-Generation
3G	3 rd Generation
3GPP	3 rd Generation Partnership Project
4G	4 th Generation
5G	5 th Generation
5G-ACIA	5G Alliance for Connected Industries and Automation
6G	6 th Generation
AD	Autonomous Driving
ADAS	Advanced Driver Assistance Systems
AGV	Autonomous Guided Vehicle
AI	Artificial Intelligence
AMR	Autonomous Mobile Robot
AP	Access Point
AR	Augmented Reality
AVC	Advanced Video Coding
CAN	Controller Area Network
CAN FD	CAN Full Duplex
CAV	Connected and Automated Vehicles
CCU	Connectivity Control Unit
CompN	Computation Node
CRT	Cathode Ray Tube
DL	Downlink
DoF	Degree of Freedom
DUT	Device Under Test
D2D	Device to Device
E/E	Electrical/Electronic
ECU	Electronic Control Unit
EN	Entity
EV	Electric Vehicles
FOV	Field of View
FR	Functional Requirement
gNB	gNodeB (i.e., the functional equivalent of a base-station)
GNSS	Global Navigation Satellite System
HC	High Capability
HEVC	High-Efficiency Video Coding
HMI	Human-Machine Interface

HPCU	High-Performance Computing Unit
IIoT	Industrial Internet of Things
IMU	Inertial Measurement Unit
In-X	In entity (e.g., in a car, in a robot, etc)
IPU	Image Processing Unit
IT	Information Technology
KPI	Key Performance Indicator
KVI	Key Value Indicator
LED	Light Emitting Diode
LC	Low Capability
LCD	Liquid Crystal Display
LIN	Local Interconnect Network
MCS	Modulation and Coding Scheme
ML	Machine Learning
MNOs	Mobile Network Operators
MOST	Media Oriented Systems Transport
O&AM	Operation & Administration Maintenance
OFF	Compute Offload
OT	Operational Technology
OTA	Over The Air updates
PLC	Programmable Logic Controller
PMI	Precoding Matrix Indicator
PoC	Proof of Concept
RIS	Reconfigurable Intelligent Surface
ROI	Regions of Interest
RRM	Radio Resource Management
SMS	Short Message/Messaging Service
SN	Subnetwork
SNE	Subnetwork element
SNM	Subnetwork Management
SDGs	Sustainability Development Goals
TC	Technology Component
TM	Transmission Mode
TPMS	Tire Pressure Monitoring Systems
TRL	Technology Readiness Level
TSN	Time Sensitive Networking
UE	User Equipment
UL	Uplink

URLLC	Ultra-Reliable Low Latency Communication
VR	Virtual Reality
XR	Extended Reality

EXECUTIVE SUMMARY

This report is the second deliverable of the 6G-SHINE work package (WP2) and provides definitions of scenarios, use cases, and service requirements for various types of subnetwork categories. Three subnetwork categories are considered in 6G-SHINE, namely the consumer, industrial, and in-vehicle subnetwork categories. This deliverable expands the initial definition of use cases and scenarios presented in D2.1, by refining descriptions, deployments and traffic characteristics, presenting thoroughly the key value benefits of in-X subnetworks. It also describes the architectural components of subnetworks, and their functional requirements for each use cases.

Subnetwork operation in an entity (in-X) is deployed in all 6G-SHINE use cases. Hence, the definition of In-X subnetwork is specified in order to provide guideline and reference when describing the use-cases. The subnetworks and the interactions to the 6G parent network involve various network elements. Each element may have different and unique role(s). Furthermore, a subnetwork may have various types of communication modes. A use case may require a certain subnetwork architecture that can be different than other use cases. The use-cases for each subnetwork categories are described below.

For the consumer subnetworks, the identified use cases include Immersive Education, Indoor Interactive Gaming, Virtual Content Production of Live Music, and Augmented Reality (AR) Navigation. These diverse use cases aim at supporting enhanced and immersive user experience. High data-rates and low latency are the Key Performance Indicators (KPIs) for these use cases. These KPIs are mostly required to deliver high resolutions, wide-angle, and high frame rate video.

In industrial subnetworks, the use cases are represented using a bottom-up approach, starting from the subnetwork in a single entity to a complex subnetwork with multiple entities. The use cases identified in this category are Robot control, Unit Test Cell, Visual Inspection Cell, Subnet Coexistence in Factory Hall, and Subnetwork Segmentation and Management. These use cases are defined with the objective to maintain the automation process in the manufacturing production line for optimal operation. The network traffic characteristics of these use cases mandate low data rates with ultra-low latency. Many connected devices are expected to be deployed and resulting in high network traffic in certain conditions.

In the in-vehicle subnetwork category, the representation of the use cases also follows a bottom-up approach similar to as the industrial subnetworks case. The identified use cases are Wireless Zone Electronic Control Unit (ECU), Collaborative Wireless Zone ECU, Inter-Subnetwork Coordination, and Virtual ECU. The objective of realizing these use cases is to design 6G-native in-vehicle wireless subnetworks that are capable of providing dependable service levels like wired networks. In principle, this objective can also be applied to other subnetwork categories. These use cases are characterized by multiple network traffic flows with varying requirements, demanding deterministic network performance (ultra-low bounded latency and high reliability). Extreme reliability and low latency are required in some of the use-cases with the primary objective to improve the safety of the road users.

A principle set of KPIs for the aforementioned use cases in the three subnetwork categories has been designated at the outset and would be revisited at different stages of the project as the work evolves to safeguard their compatibility with the use cases. The purpose of these KPIs is to ensure that the required services of a use case can be supported. It is noteworthy that some of the KPI requirements may not be fully supported through the existing technology. However, it is expected that the research and development under different technical components of the project would finally allow the application of these KPIs to the identified use cases. In relation to this, the mapping of 6G-SHINE technology components (TCs) to the use-cases in each subnetwork category is provided. In the context of social, economic, and environment sustainability, the Key Value Indicators (KVI) associated with the identified uses cases are also investigated, including the enabling factors (i.e., KV enablers) of the identified KVI(s). This study facilitates to understand the societal impact of the research undertaken in this project.

This deliverable will be used as the reference for other activities across the involved WPs of the project, such as TCs development and proof of concept (PoC) activity. The other WPs may select the identified use-cases and develop a specific TCs based on the deployment scenario, subnetwork architecture, KPI, and requirements. Within WP2, we will also characterize radio propagation at different frequency bands and explore network architectures for in-X subnetworks of the selected use cases.

1 INTRODUCTION

6G-SHINE is one of the European Union 6G projects under the 6G-SNS Stream B (research for revolutionary technology advancement toward 6G) framework. This report is the second deliverable of WP2 and the scope of WP2 is on defining scenarios, use cases, and requirements. Specifically, this report is the refinement of our previous deliverable D2.1 Initial Definition of Scenarios, use cases and service requirements for In-X Subnetworks. This report presents the definition of In-X subnetworks and a set of use cases for the consumer, industrial, and in-vehicle subnetwork categories defined in 6G-SHINE. The operation of In-X subnetwork is the major characteristic of 6G-SHINE use cases. Hence, it is essential to provide the definition of In-X subnetwork. Subsequently, the following aspects are described for the use cases in 6G-SHINE:

- Use case description and its operation
- Deployment and Subnetwork architecture
- Traffic characteristics
- KPIs and requirements aspect
- KVis aspect
- Challenges to 6G System

1.1 OBJECTIVE OF THE DOCUMENT

This deliverable covers the work for the definition of relevant scenarios, assumptions, and use cases for the subnetworks along with KPI requirements. The objective of this report is to identify numerous relevant use cases including the descriptions, operation flows, and pre/post conditions covering consumer, industrial, and in-vehicle subnetwork categories. The KPIs and KVis related to the use cases are stipulated. Finally, the potential mapping of the 6G-SHINE TCs to the use cases in each subnetwork category is also identified. The selected use cases identified in this report will be used for further work on WP2 and other WPs, particularly in the development of TCs and PoCs.

1.2 STRUCTURE OF THE DOCUMENT

This report is organized as follows. Chapter 1 provides the introduction, including the objectives and the methodology for defining the use cases, KPIs, and KVis. Chapter 2 describes the definition of In-X subnetwork. Chapter 3, 4, and 5 describe numerous use cases in the consumer, industrial, and in-vehicle subnetwork categories, respectively. In each chapter, we elaborate the respective background, and the KVis for the given category. Each use case is thoroughly covered with high-level descriptions, pre- and post-condition aspects, operation flow, subnetwork architecture, and KPI & requirements. The traffic characteristics are provided for the selected use cases. Furthermore, each of these chapters describing subnetwork categories is concluded by explaining how the TCs in 6G-SHINE could address the challenges in the respective category. Finally, conclusions are drawn in Chapter 6.

1.3 METHODOLOGY

1.3.1 Defining Use Cases

Figure 1 illustrates the focus of the 6G-SHINE project. The subnetworks are intended to replace traditional cabled media for demanding use cases, and feature the following main characteristics:

- Short range (below 10 meters) low-power cells meant to offer localized connectivity by offloading larger networks with demanding services.
- Support services with rigorous requirements in terms of latency, reliability, and data rates.
- Consist of one or more Access Point (AP(s)) with integrated edge processing capabilities and a potentially large number of cost-effective and potentially computationally constrained devices with limited form factor, such as sensors/actuators.
- Support the stand-alone operation in case the connection with an umbrella 6G network is not available or it is not needed.

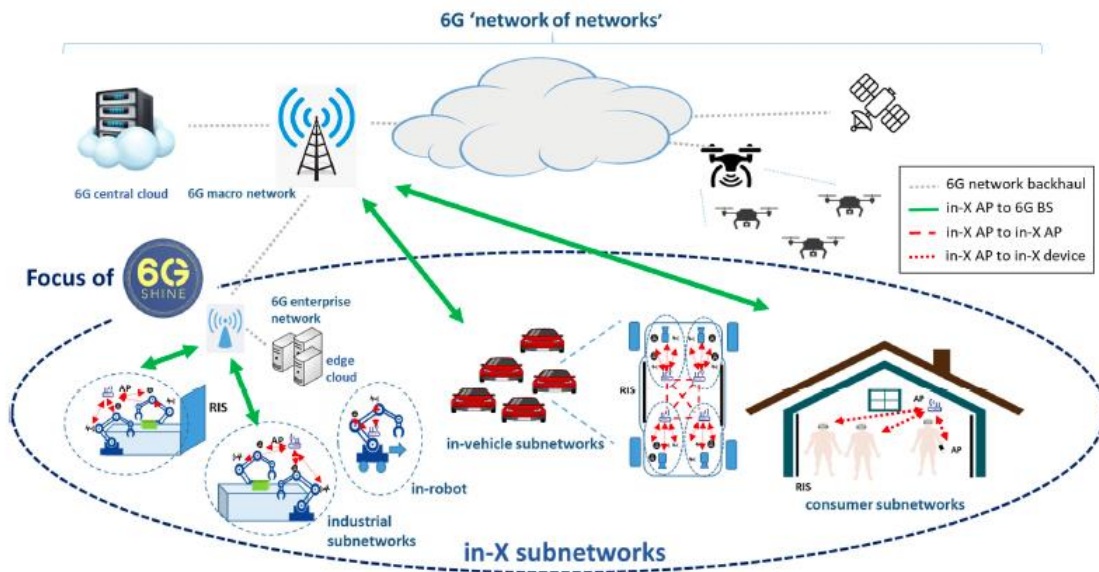

Figure 1: Illustration of 6G-SHINE project in supporting various use cases

Based on the above stated characteristics, various use cases can be defined to address the future needs/requirements. In order to ensure that diverse use cases are identified for 6G deployments, we defined the use cases for the following three subnetwork categories:

- Consumer
- Industrial
- In-vehicle

1.3.2 Definition of Key Performance Indicators

Key Performance Indicators (KPIs) refer to the measurable metrics that are used to assess and evaluate the performance and effectiveness of various aspects of the communication system. These KPIs provide insights into the overall efficiency and quality of infrastructure, services and operations provided by the communication system. In this project, we consider the traditional set of KPIs that are well established by the standardization bodies, such as 3GPP. For instance, transmission (packet/bit) error rate, data rate, latency, and reliability. We consider those as common KPIs to evaluate or to assess the performance of wireless connectivity. These KPIs are also adopted in 6G SHINE. Additionally, we have also identified

some other KPIs which could still be derived or related to the common KPI. One or more of the derived KPI can be applicable to a specific use case. The KPIs are briefly described below.

- **Data rate:** rate at which data is transmitted from one point to another within the network. It is closely related to the concept of bandwidth, but it specifically emphasizes the actual data transfer rate rather than the overall capacity.

The relevant or derived KPI(s):

- *User experienced data rate:* the minimum data rate required to achieve a sufficient quality experience, except for scenario for broadcast like services where the given value is the maximum that is needed [1].

- **Reliability:** percentage of packets successfully delivered within the time/latency constraint required by the target service or domain function out of all the packets transmitted [1].

The relevant or derived KPI(s):

- *Communication service availability:* percentage value of the amount of time the end-to-end communication service is delivered according to a specified QoS, divided by the amount of time the system is expected to deliver the end-to-end service [1].
- *Communication service reliability:* ability of the communication service to perform as required for a given time interval, under given conditions [2].
- *Survival time:* the time that an application consuming a communication service may continue without an anticipated message [1]
- *Jitter:* deviation from true periodicity of a presumably periodic signal.
- *Packet Error Rate (PER):* ratio of number of packets received in error to total number of transmitted packets.

- **Latency:** time delay between the initiation of a data transfer or command and its actual reception or execution.

The relevant or derived KPI(s):

- *End-to-End latency:* the time that it takes to transfer a given piece of information from a source to a destination, measured at the communication interface, from the moment it is transmitted by the source to the moment it is successfully received at the destination [1].
- *Packet Delay Budget (PDB):* a limited time budget for a packet to be transmitted over the air from a base-station (gNB) to a UE [3].
- *Control loop time (or control cycle time):* time interval between consecutive updates or iterations of a control system. In industrial and automotive applications, this represents the frequency at which the control system processes sensor data, computes the appropriate response, and sends commands to actuators.
- *Transfer interval:* time difference between two consecutive transfers of application data from an application via the service interface to 3GPP system [2].
- *Determinism:* ability to guarantee that data is delivered within specific time constraints or time bound.

- **Synchronization threshold:** A synchronization threshold can be defined as the maximum tolerable temporal separation of the onset of two stimuli, one of which is presented to one sense and the

other to another sense, such that the accompanying sensory objects are perceived as being synchronous [1].

The relevant or derived KPI(s):

- *Clock Synchronicity*: the maximum allowed time offset within the fully synchronised system between UE clocks [2].

In addition to the above KPIs, we consider other potential KPIs that could still be relevant to 6G-SHINE. These additional KPIs may not only be required for evaluating the performance of a wireless links but also for the optimal operation of subnetworks in 6G-SHINE. For example, system capacity (e.g., the supported number of simultaneous connected devices without compromising each wireless link), power consumption, signalling overhead, computational complexity, and possible distribution/transfer of computation within a subnetwork.

All of the above KPIs are relevant for 6G-SHINE project. However, we may not necessarily use those KPIs in this report. At least, some of the KPIs are discussed in the subsequent chapters and some others may be specifically addressed in the relevant WPs, especially when the technical solution(s) is required to achieve certain KPIs.

1.3.3 Definition of Key Value Indicators

The key values (KVs) within 6G-SHINE are initially defined based on the work described in [4]. Firstly, the United Nations have developed the 2030 Agenda for Sustainable Development where the 17 sustainability development goals (SDGs) have been defined and shown in Figure 2 [5]. The descriptions and goal targets of each SDG are described in [6].



Figure 2: The 17 UN Sustainability Development Goals (SDGs) (figure taken and simplified from [5])

Furthermore, the Stockholm Resilience Centre has grouped those development goals and visualized them as shown in Figure 3 [7]. Here, these groups are associated with the key value (KV) to be addressed in this project, named as economic sustainability, social sustainability, and environment sustainability.

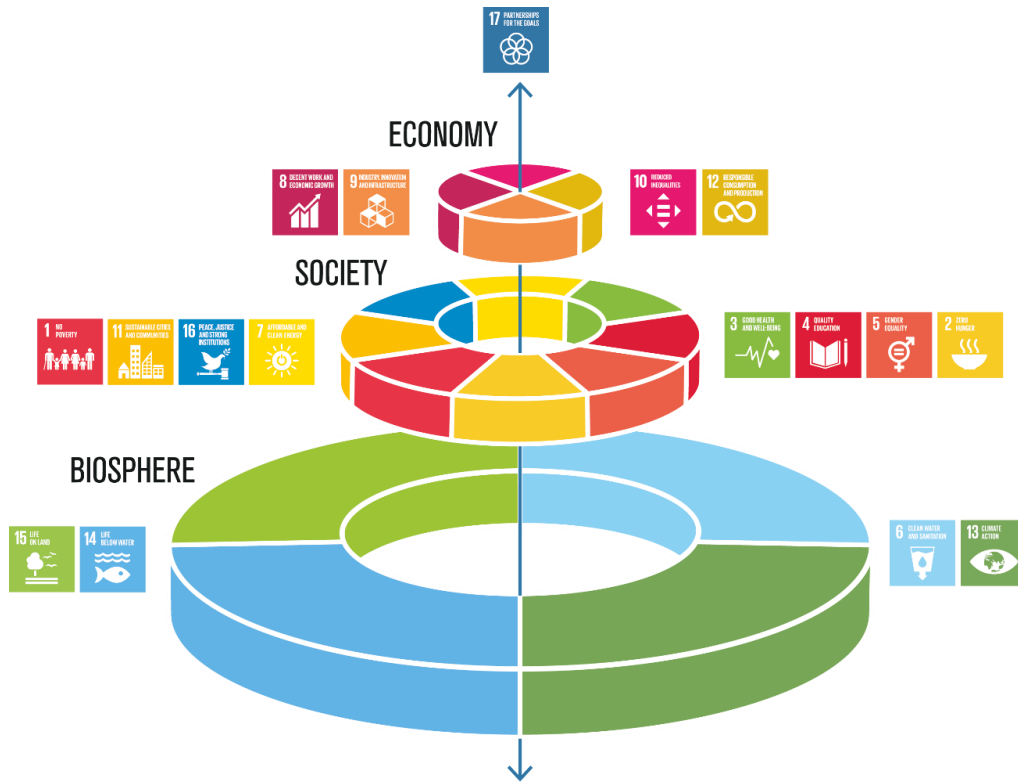

Graphics by Jerker Lokrantz/Asente

Figure 3: The 17 SDGs grouped by Stockholm Resilience Centre (figure taken from [7])

Subsequently, the indicator for each KVs above will be derived further for each use cases category as described in Section 1.3.1. Key Value Indicator (KVI) is a way to measure the identified KV. We can foresee the KV(s) to have a direct or indirect impact on human society. In this context, the KVI should be able to measure the impacts of the new generation wireless technologies developed in this project on both qualitative and/or quantitative evaluation. A technology becomes valuable if it enables KV and KVI being useful as providing the metrics to visualize and to demonstrate the value of the technology itself [4]. Furthermore, the assessment towards KVI is important to facilitate in addressing the SDGs by United Nation.

A use case can be established depending on the key value enablers and these enablers are typically related to fulfilling the technical requirements. According to [4], KVIs can be used to demonstrate value but cannot be directly used to design for value. The KVI enablers can be used for impacting the technical design to support the use-cases. Lastly, the Key Performance Indicator (KPI) can be introduced as a set of technical numerical targets associated to one or more KV enabler. The relation of these aspects is illustrated in Figure 4.

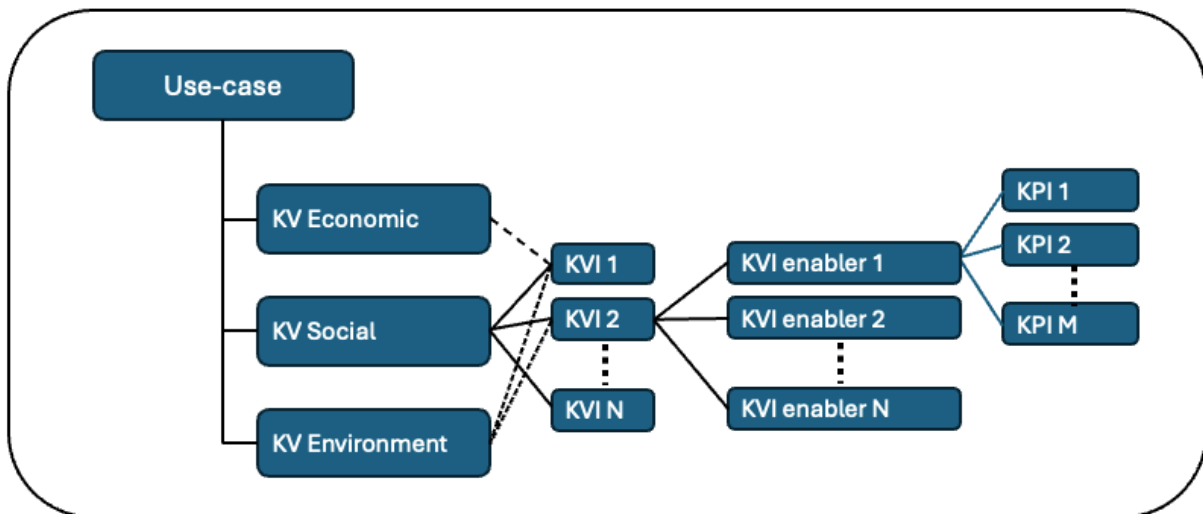

Figure 4: Illustration the relation of KV, KVI, and KPI of a use-case

In relation to 6G-SHINE project that focuses on low technology readiness level (TRL) research, KVIs are at the center of our technology design and development. Note, the descriptions of TRL can be found in [8]. We can then speculate on how the designed technology components, when integrated in a complete system design for specific use cases (beyond the scope of this project), can be the building blocks that enable the fulfillment of KVIs. According to the scheme proposed in [4], we focus on *objective assessment*. 6G-SHINE partners from vertical sectors have indeed thorough experience on assessing the relevant KVIs, and their contribution is fundamental in the design of KVI-aware technology components.

In-X subnetworks can be used in various sectors and use case categories. In 6G-SHINE we focus on three categories -consumer, industrial, and in-vehicle- and have defined relevant use cases for each category where our technologies can have a major impact. Though scenarios and use cases are rather different, we identify some common KV benefits introduced by the concept of in-X subnetworks. These KV benefits can also be considered as common KV indicators. Both are used interchangeably in this report. The common KVIs means it is applicable to all of the use-cases. The specific KVIs of each use-cases will be further elaborated in separate sections.

Environment sustainability

The concept of in-X subnetworks can contribute to improve environment sustainability as follows:

- **Reducing cable harness.** In-X subnetworks can bring wireless to a higher level of pervasiveness than what experienced in today's networks, substituting cables for short-range critical communications. While 5G has already done a tremendous effort in reducing cable harness, most of today's installations with very demanding communication requirements are still wired as 5G cannot cope with them. Materials used for manufacturing cables are an environmental hazard. For example, the mining and processing of copper can result in around hundred gigajoules of energy emission [9]; besides, most of the rock surface around copper deposit is regarded as wasted. Production of materials for jacketing and shielding cables (e.g., poly vinyl chloride) requires fuel consumption and can release toxic gases and chemicals, besides greenhouse gases like chlorine and vinyl chloride monomer. The jacket structure is also

composed of lead; the chaffing and deterioration of cables can lead to the additive getting loose and accumulating on ceilings, floors, and walls of buildings. Besides, the plastic material used as shielding jackets are easily inflammable, releasing toxic gases and potentially spreading fire and gases throughout a building in case they are stored in plenum spaces. It is obvious that a massive reduction of the cable harness enabled by in-X wireless subnetworks can bring to significant improvement in terms of environmental hazard.

- **Enabling modular equipment.** The replacement of cables with wireless can enable the possibility of making equipment more flexible, portable and modular, as different parts do not need to be rigidly connected. Making equipment modular has major benefits in terms of environment sustainability, since only defective components are to be repaired or refurbished, reducing the need for new devices. Modular equipment also eases the disassembly of parts, enabling the possibility of extracting valuable materials and reusing them for new devices.
- **Energy efficiency.** This can influence the design of 6G-SHINE technology components. A major hypothesis of the 6G-SHINE project is indeed that, short-range communication and the possibility of leveraging knowledge of the operational environment (and to a large extent, the possibility of controlling the propagation environment) and specific operational characteristics (e.g., devices in static and predictive motion) can lead to the possibility of achieving demanding requirement with minimum energy.
- **Architecture enhancements and edge computing.** In-X subnetworks introduce major architectural innovation in wireless networks, enabling connectivity and computing capabilities at the very end of the 6G ‘network of networks’. The possibility of processing the most critical traffic at the network edge can enable better scalability and reduce the amount of critical traffic in the network. Transferring traffic generated by multiple deployments with very demanding requirements in terms of latency or data rate over large portions of the network require indeed a large amount of processing resources, with associated negative environmental footprints related to higher energy consumption and cooling costs. By bringing intelligence at the edge of the network, traffic can remain local and processing capabilities are tailored to the need of the specific subnetwork installation.

Social sustainability

In-X subnetworks can contribute to social sustainability as follows:

- As mentioned above, the architectural innovation enabled by in-X subnetworks can bring the processing capabilities very close to the physical subnetwork installation. Besides the environmental benefits, this can ease the processing of critical traffic, and ensure privacy and security as critical data are not transported through the broader network infrastructure.
- The improved scalability enabled by wireless subnetworks can ease the support of a larger number of sensors by the same control infrastructure; for certain use cases, e.g., in-vehicle, this can contribute enhancing safety with respect to rigid wired installations.
- Ensuring capillary coverage via tailored wireless installations that offers applications and services of unprecedented quality, can contribute enhancing people trust on technology and digital capabilities. People without extensive digital training and comprehension can have a smoother experience in accessing services via wireless, as this does not require a cumbersome and time-consuming wired installation process.

Economic sustainability

Economic sustainability can be addressed by in-X subnetworks as follows:

- In-X subnetworks represent a major innovation in the wireless communication landscape, given their capability of operating as standalone entities, while being part of a broader 6G infrastructure. We believe their peculiar nature combined with the diverse set of use cases where subnetworks can be major actors, can inspire novel business models for the mobile communication sector, as well as for the verticals. For example, a mobile operator can offer as a service the control and management of a number of in-X subnetworks installed in facilities such as factories and schools, ensuring a quality of service that cannot be achieved by uncoordinated ad-hoc installations.
- In-X subnetworks can make wireless installations more agile, portable, and flexible. This can help reducing installation and maintenance costs with respect to e.g., fieldbus connections, requiring complex wired setups.
- Besides its positive environmental footprint, the possibility of having modular equipment enabled by the enhanced wireless capabilities, can reduce the cost of upgrades as only defective components are to be replaced, ultimately extending lifetime of installations.

A more detailed description of the KVs addressed by the specific use cases, as well as their enablers, will be presented in the next sections.

2 IN-X SUBNETWORK ARCHITECTURE

This chapter provides the essential definitions and nomenclature for all elements that are relevant in the different use cases. They include network elements, their roles and different communication modes. A reference architecture is provided, as well, to highlight the different aspects of the first considerations regarding an in-X subnetwork architecture. Concrete use case-specific in-X subnetwork architectures will be provided in Chapters 3 to 5. Finally, a few hints are given regarding functional requirements, which will also be detailed for each of the use cases in Chapters 3 to 5.

2.1 INTRODUCTION

The large diversity of the different use cases and use case categories demand a top-down approach to define essential aspects of an in-X subnetwork architecture with, nevertheless, a strong focus on use case-related requirements.

In this top-down approach, 6G-SHINE first defines broad categories for network elements, which are first defined according to the capabilities and then to be defined based on functionalities. Such capabilities mostly refer to computational and communication capabilities, as well as power consumption. Then, high-level functionality clusters are associated via so-called roles, which indicate groups of communication, management and compute functionalities or features.

We propose network elements with different degrees of capabilities. It is important to note that these degrees are only defined relative to each other on a per-use case basis. This means that the capabilities of a low-capability element of one use case cannot necessarily be compared to the ones of another low-capability element defined for another use case. However, it is important to compare different capabilities of network elements per use case, as this will provide indications for a certain role assignment in each of the different 6G-SHINE use case.

2.2 NETWORK ELEMENTS OF THE PARENT NETWORK

For the regular case, we assume that subnetworks are integrated in a 6G parent network, whose elements are described next and summarized in Table 1.

2.2.1 6G Base Station (6G BS)

A 6G base station comprises the radio access network components of the parent network, to which subnetworks can be connected. It might realize a subset of the signal processing and coordination functionalities under investigation in WP3 and WP4.

2.2.2 6G Core Network (6G CN)

The 6G core network comprises all necessary network functions to run, operate and manage the parent network. It might also include functionality to manage and operate subnetworks associated to the parent network. There might exist two different subtypes: Public networks and non-public networks

(enterprise or campus). A non-public network can provide a dedicated 6G core network to a certain scenario, such as an industrial factory.



2.2.3 6G Network Compute Node (CompN)

A 6G compute node is a component that offers computing resources, and which is not part of a subnetwork, but instead can be used by multiple subnetworks. The 6G core network might be involved in provisioning of the compute resources.

2.2.4 User Equipment (UE)

We consider standard user equipment (UE) as defined by 3GPP. The UE does not necessarily have to be part of a subnetwork but there is the possibility to have a communication relationship established between such a UE and other elements within subnetworks.

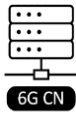
Table 1: Symbols of Parent Network Elements

Element	Abbreviation	Symbol
6G Base Station	6G BS	
6G Core Network	6G CN	
6G Network Compute Node	CompN	
User Equipment	UE	

2.3 ELEMENTS IN A SUBNETWORK

We propose four categories of elements being present in a subnetwork, which – as mentioned above – are defined according to their capabilities. They are summarized in Table 2.

2.3.1 Element with High Capabilities (HC)

An element with high capabilities is a device/node with increased capabilities in terms of networking and computation. Such a node might act as the central communication node in a subnetwork and also

might offer compute resources to other devices in the subnetwork. Multiple such HCs can be installed in a single subnetwork. An HC element can be a user equipment as defined by 3GPP or a non-3GPP device, which include also access points (APs).

2.3.2 Element with Low Capabilities (LC)

An element with low capabilities is similar to an HC but has reduced capabilities in terms of networking and computation. This can limit the functionalities this device provides to the subnetwork and even there might be no connection between the LC and the 6G base station. In a hierarchical or nested subnetwork, the LC might act as an aggregator. An LC element can be a user equipment as defined by 3GPP or a non-3GPP device, adhering to the description in this subsection.



2.3.3 Subnetwork Element (SNE)

Subnetwork elements are computationally constrained devices that have limited form factor, cost footprint, power/energy, and that include devices such as sensors/actuators. Similar to the HC and LC, an SNE device can be a user equipment as defined by 3GPP or a non-3GPP device, too.

2.3.4 Reconfigurable Intelligent Surfaces (RIS)

A reconfigurable intelligent surface is an electromagnetic passive element that can beneficially influence the wireless channel. The descriptions and the fundamental operations of RIS can be found in [10].

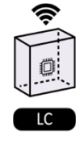
Table 2: Symbols of the Elements Involved in Local Communication

Element	Abbreviation	Symbol
Element with High Capabilities	HC	
Element with Low Capabilities	LC	
Subnetwork Element	SNE	
Reconfigurable Intelligent Surface	RIS	

2.4 FURTHER DEFINITIONS

In the following, we also introduce two other terms, entity and in-X wireless subnetwork, which are important for the definition of the deployment architectures. Their abbreviations and symbols are given in Table 3.



2.4.1 Entity (EN)

The concept of entity stands here for specific use case unit with limited operational radius, where one or more subnetworks can be installed for a set of coherent and correlated operations. Entities can be robots, production modules, vehicles, but even classrooms for consumer type of applications. A single entity (e.g., vehicle or robot) may feature more than one subnetwork.

2.4.2 In-X Wireless Subnetwork (SN)

In-X subnetworks are special purpose networks that can support localized and high-performance connectivity within an entity. They are short range (below 10 meters), typically low-power, cells, meant at offering very localized connectivity by offloading larger networks of demanding services. They consist of one or more HCs and/or LCs with integrated edge processing capabilities (in case of HCs) and a potentially large number of cost-effective very constrained devices with limited form factor, such as sensors/actuators, called SNEs. They can operate as stand-alone subnetworks in case the connection with an umbrella 6G network (6G base station) drops or is intermittent. The umbrella 6G network can take care of efficiently orchestrating the subnetwork operations when connection is available. Non-standalone subnetworks always depend on the umbrella 6G network.

Table 3: Symbols for Entities and Subnetworks

Element	Abbreviation	Symbol
Entity	EN	
In-X Wireless Subnetwork	SN	

Important note: the term access point (AP) was used in the previous document (Deliverable D2.1) and also some parts in this document to refer to an essential network element being part of an in-X subnetwork. This term already implies certain functionalities, which might be different for the various use cases, so that this is something to be avoided. AP is therefore replaced by the more neutral terms HC and LC, which also differentiate different degrees of capabilities and provide more flexibility to define

various in-X subnetwork architectures, which can be seen in Chapters 3 to 5. For some use cases, the term AP can still be used explicitly for a particular HC or LC.

2.5 ELEMENT ROLES

Roles are high-level descriptions of sets of functionalities or features, and they can be assigned to different elements present in the use case. The following roles are defined in the context of 6G-SHINE and summarized in Table 4.

2.5.1 The Gateway (GW) Role

An element with the gateway role can manage the data traffic routing within and/or across subnetworks. In special cases, it can act as intra-SN or cross-SN relay as well as gateway towards the 6G parent network.

2.5.2 The Compute Offloading (OFF) Role

An element with the compute offloading role uses its capabilities to orchestrate application and/or network function offloading from source elements to target elements. Or, it is a provider or donor of compute resources to another element within the same or another subnetwork.



2.5.3 The Radio Resource Management (RRM) Role



An element with the radio resource management role uses its capabilities to manage the radio resources of one or multiple other elements within a subnetwork (central, hybrid, distributed). Such management functions can also consider jamming, RIS (if present) and licensed/unlicensed spectrum in general.

2.5.4 The Subnetwork Management (SNM) Role

An element with SNM functionality manages the operational activities of elements within a subnetwork. This might include authentication, handover procedures, master clock roles, and monitoring of network performance.

Table 4: Symbols for the Different Roles

Role	Abbreviation	Symbol
Gateway Role	GW	
Compute Offloading Role	OFF	

Radio Resource Management Role	RRM	
Subnetwork Management Role	SNM	

2.6 REFERENCE ARCHITECTURE

Figure 5 shows an example architecture as an illustrative reference with three entities employing one or more than one subnetwork each. The leftmost entity has three subnetworks in a nested setup with HC and LC as “head nodes”. RIS are either integrated in a subnetwork or standalone as part of the parent network. SNEs are usually end nodes, but also exceptions exist where they can relay information to another SNE. There can also be subnetworks without SNEs but only with HCs and LCs instead such as in the rightmost subnetwork. A UE is explicitly considered in case it is outside of any subnetwork but can communicate with elements within a subnetwork, i.e., with an HC, LC, or SNE. In many cases, there exist communication links between HCs and LCs, and with this also between subnetworks of the same entity or different entities. It can also be seen that different communication structures are possible, such a tree-like, meshed or setups with multi-connectivity of SNEs towards more than one HC/LC.

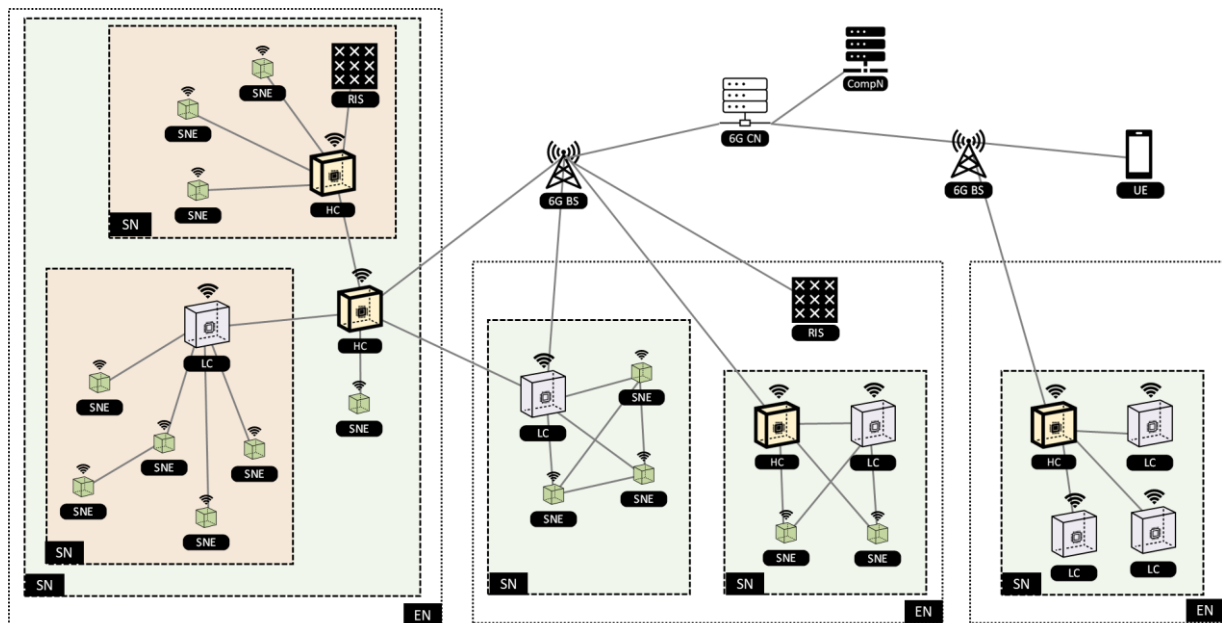

Figure 5: Reference Architecture

In Figure 6, an example role assignment can be seen for the leftmost entity of Figure 5.

Gateway Roles:

All three “head nodes” (two HCs and one LC) have the GW role as they can relay and distribute information in their subnetworks and among the SNE. In addition, the HC of the green SN also acts as gateway towards the parent network while there is no other direct communication of any other element

in the SNs towards the parent network. Also, another SNE has the GW role as it relays towards another SNE.

RRM Roles:

The upper HC (being part of the yellow SN) has the RRM role, which means that it can manage radio resources within and beyond its subnetwork, including steering the RIS. At the same time, the 6G BS also employs RRM, so that a hybrid form of radio resource management is installed in this case.

Compute Roles:

Furthermore, two nodes, that are the HC in the green SN and the CompN, have the compute offloading role, which enables them to manage and/or offer computational offloading to other entities within their domain, such as within the green SN (including the orange SN, as well).

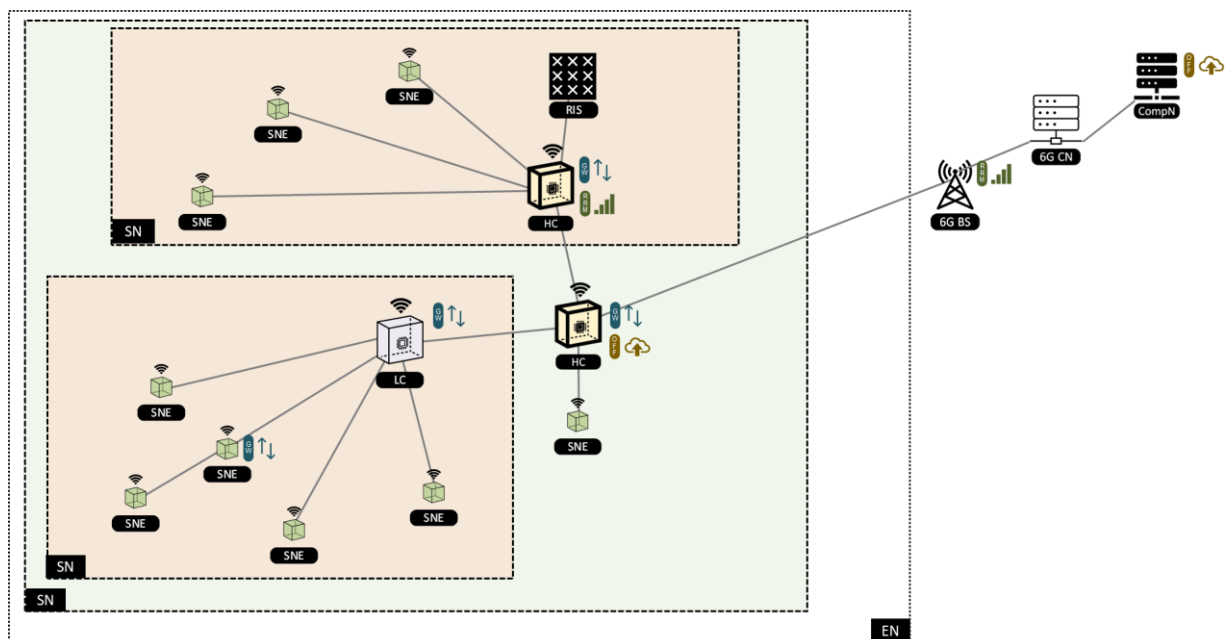

Figure 6: Example Role Assignment

2.7 COMMUNICATION MODES

In general, there exists a large number of different possibilities of communication relationships between the various types of elements. One can distinguish between direct and indirect (such as relayed) communication modes. The following Table 5 provides an overview and highlights, to which extent these relationships are relevant for the 6G-SHINE use cases. The different possibilities of the communication modes listed in the table are also illustrated in Figure 7. More details are provided in Chapters 3 to 5.

Table 5: Possible Communication Relationships Between Elements.

Communication Relationship	Relevance
	Direct Communication

①	Between SNEs	Relevant in rare cases.
②	SNE to LC/HC	Standard communication mode present in the use cases.
③	Between LC/HC (same level)	Considered in some special cases, e.g., for load balancing or equally relevant elements.
④	Between LC/HC (different levels)	Standard communication mode present in the use cases.
⑤	LC/HC to 6G network	Relevant for some of the use cases.
⑥	SNE to 6G network	Typically, not considered in the use cases.
⑦	Between UE and 6G network	Relevant for some of the use cases.
Indirect Communication		
①	Between SNEs via LC/HC	Relevant in rare cases.
②.1 ②.2	Between SNEs in different SNs via LC/HC (2.1) or via 6G parent network (2.2)	Relevant in rare cases.
③.1 ③.2	SNE to LC/HC via LC/HC (3.1) or via 6G parent network (3.2)	Standard communication mode present in the use cases, especially with LCs acting as data aggregators.
④	SNE to 6G net via LC/HC	Typically, not considered in the use cases.
⑤	Between LC via HC	Standard communication mode present in the use cases.
⑥	UE to SNE/LC/HC via 6G parent network	Only in use cases with a UE being present.
⑦	SNE to LC/HC via SNE	Relevant in exceptional cases.
⑧	LC/HC to 6G parent network via LC/HC	Relevant for some of the use cases.
⑨	SNE to SNE via SNE	Typically, not considered in the use cases.

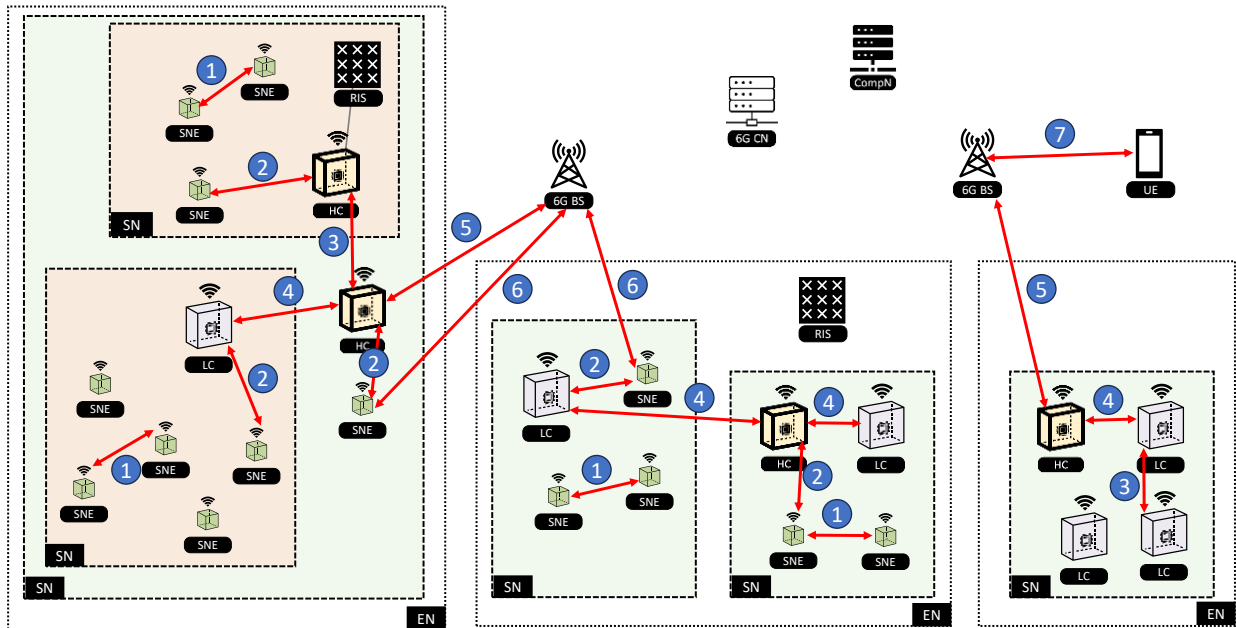

a) Direct communication mode

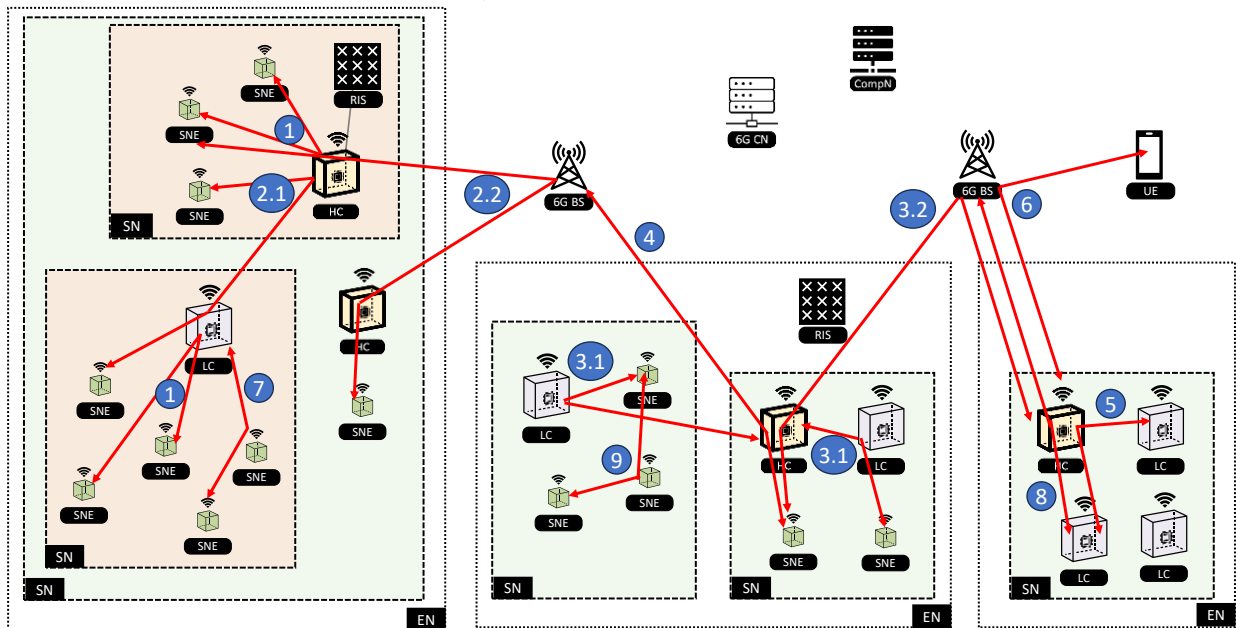

b) Indirect communication mode

Figure 7: Example of communication modes for the reference architecture

2.8 GENERAL HINTS ON FUNCTIONAL REQUIREMENTS

In contrast to quantitative performance requirements, functional requirements describe concrete qualitative aspects, functions, features, or behaviours of systems. Functional requirements typically are indicators for certain architecture-related design decisions. In this regard, the use case analysis in Chapters 3 to 5 includes information regarding the functional requirements, as well. The functional requirements are formulated in a form similar to the ETSI/3GPP specifications. This means that “shall”

indicates a mandatory functional requirement. Often, the term “system” is used in the requirement description. The “system” describes the collection of all elements relevant for the use case.

Some elements, in particular, parent network elements, can still be present in a certain setup of a use case, while its absence in the use case description indicates that, for the sake of use case analysis, these elements are irrelevant.

3 CONSUMER SUBNETWORKS CATEGORY

The subsequent three chapters will detail a selection of example use cases, organized by category: Chapters 3, 4, and 5 will cover use cases for the consumer, industrial, and in-vehicle subnetwork categories, respectively. The respective backgrounds of the categories will be presented along with a summary of expected characteristics and the required KPIs and KVIs, which have been introduced in chapter 1. The descriptions of the respective use cases will make use of the definitions and architecture elements for in-X subnetworks which were introduced in the previous chapter 2. Traffic characteristics are provided for a selection of the use cases. Finally, each of these chapters will be concluded with a summary of key challenges and how the TCs to be investigated in 6G-SHINE can help to solve them.

We start with the consumer use cases, giving a background of the general properties in subchapters 3.1 through 3.4, followed by the individual use cases in subchapter 3.5, and the summary of challenges in subchapter 3.6.

3.1 STATUS QUO ON CONSUMER NETWORKS

Wireless telecommunication (practically telephony) started as a business application with a low adoption rate in the last century because of the prohibitive cost compared to wireline communication. This changed considerably with the introduction of second-generation (2G) technology. A virtuous cycle was sparked by the transition from analogue national to digital regional or global standards, allowing higher adoption rates, larger production volumes, and consequently lower unit costs, enabled by the assignment of additional spectrum that could be used more efficiently, thanks to advanced digital processing technology. This allowed consumers to afford wireless services and in turn, increased the addressable market. After the turn of the century, 3G, and subsequently 4G and 5G technologies perpetuated that trend and introduced the support of mobile data services on top of telephony and short-message service (SMS). The new device category of smartphones leveraged data services, i.e., connectivity to support various web-based services, i.e., take advantage of ever-increasing information that is available on the web. Subsequently specific apps targeting mobile users were developed, that were tailored both to the capabilities (but also limitations) of smartphones and to the specific needs of consumers on the go, wherever they were.

Immersive media were boosted by the transition from bulky Cathode-Ray Tubes (CRTs) to flat screen Liquid Crystal Display (LCD) and Light Emitting Diode (LED) monitors. These allowed the presentation of more content at better quality in terms of screen size, number of pixels, frame rate, and resolution. Transfer of video footage to the monitors was again facilitated by the change from analogue to digital technologies. While mobile devices, especially the smartphones, drove large parts of the consumer device business, users who demanded the highest performance had to be aware of mobile device constraints (size, energy, complexity, data rate, and latency). The top end of the consumer market, motivated by gaming, strived for ever higher performing setups of computers, networks, and displays for a gaming experience that is as realistic and immersive as possible. While for education multimedia

content has been used since a long time, from traditional films over PC based towards the laptop or tablet-based media, it was by no means the sector that was progressing technologies fastest.

3.2 EVOLUTION TRENDS

Apart from the general advancements in all of the above-mentioned technologies, it is desirable to make immersive media experiences available to a broader market, gradually expanding from specialized high-end setups (i.e., primarily for business users or most advanced early adopters and gamers).

Wireless connectivity provides free movement and enables experiencing media on the go. This is particularly useful if several devices (displays, cameras, and sensors, for one or multiple users) are involved to provide data (including video) wirelessly at optimized power consumption.

There is an evolving segment addressing the use of smartphones for a growing set of use cases, at least those allowed by the limited capabilities (screen size, resolution, connectivity, and processing power). An example of such a use case is the display of prospective purchases in the consumers home environment; even simple setups, e.g., using a cardboard-based Virtual Reality (VR) set or a smartphone, allow overlaying the desired product into a display of the local scenery to give a rough impression whether an intended purchase would fit. Gaming applications also soon emerged, as well as immersive performances for entertainment, displaying human performers or animated avatars.

Already today wireless technologies provide instantaneous information for various applications covering anything from pure entertainment up to business-critical information: The spread of smartphones and tablets has brought a variety of information sources to everybody's fingertips. Immersive technologies will make it effortless to access any information, more generally any perceivable content. A natural audio-visual experience will delight end-users who will perceive no constraints from latency, resolution, space, or time. While such technology is not yet widely utilized, we can see an emergence of extended reality (XR) headsets. Future device capabilities will be expected to favour this proliferation, progressing from initial simple concepts to more advanced devices supporting more challenging use cases.

3.3 BENEFITS AND CHALLENGES OF CONSUMER SUBNETWORKS

Providing users the freedom to move around and enabling them to enjoy services wherever they want or need is a strong benefit of wireless networks. This applies both to small-scale scenarios, e.g., within a building or a vehicle, and to large-scale scenarios where users may roam freely within the umbrella network. Several use cases adopt more than one device either per user or per user group which can naturally form subnetworks or even hierarchical subnetworks within subnetworks within the enclosing network. 6G-SHINE is expected to investigate and develop schemes that will allow running multiple connections amongst the deployed devices, supporting the individual needs of all these devices and their respective interactions with other devices and services running within the same or adjacent sets of subnetworks.

Ideally, wireless networks should be able to support all perceivable use cases. However, as wireless spectrum resources are shared and scarce, there is a limit regarding how tightly they can be reused, and

achieving consistent wireless performance will always be challenging. Therefore, it will be essential to develop schemes that may allow to adjust the available capacity by assigning optimal resources to a set of subnetworks that support the specific needs of all the devices and the respective use cases. 6G-SHINE will contribute to this goal by developing and investigating technology components for such schemes. The specific technology components to address the requirements of individual use cases are identified in the respective chapters.

3.4 KVIs OF CONSUMER SUBNETWORKS

The use cases in consumer subnetworks are introduced with the motivation to advance the KVIs as described in Section 1.3.3. The common KVIs applicable to all use-cases are elaborated in Section 1.3.3. In this section, the specific KVIs of consumer subnetworks are described. On social sustainability aspects, the new use cases, such as immersive gaming and education may enhance the user experience and also realize digital inclusion, i.e., to be part of a world where you can meet your peers from around the world in a digital environment, have fun and make new friends, etc. For education, it will affect the individual members of the community and the society in its entirety. Advancements in the education sector in terms of enabling the teachers to educate efficiently through digital tools and students to learn and grasp subjects intuitively and interactively will provide significant rewards, both commercially, intellectually, and emotionally. These can be considered as the social key values of the use cases and the associated KVIs are shown in Table 6.

Immersive education, indoor interactive gaming, and other related use cases are expected to improve social connection and interaction among people. This can be considered as one of the KVIs of these use cases. The interactive contents can also attract the pupils to join the education program, provide them easier access to the taught subjects and eventually improve the quality of education. Reduce student dropping rate can also be as the KPI. For example, in 2022, 11.1% of young men and 8.0% of young women in EU were early leavers from education, with Romania, Spain and Hungary being the most affected countries, with percentages approaching 15% [12]. Learning difficulties, lack of motivation, guidance or support, are identified among the major reasons for becoming early leavers. XR-enabled programs supported by in-classrooms subnetworks can revolutionize education and make it highly appealing to students of all ages, contributing to the reduction of the early leavers. Moreover, the evolution of user-friendly XR interfaces can improve digital literacy and ensure there is not discrimination between people with different cultural background.

On environment sustainability aspects, the least we can expect is a significant reduction in energy consumption and carbon footprint. Digital Inclusion would enable users to interact virtually, regardless of geographic location. Hence, it reduces the carbon footprint by reasonably lowering the need for business traveling. The design of the consumer subnetworks use cases in their entirety is expected to reduce overall energy consumption. Hence, we consider reducing the transportation efforts, lighter devices with less materials as the KVI for the environment sustainability.

On economic sustainability aspects, the new use cases in consumer subnetworks will create new services, features and business opportunities, to support the consumer electronics industry and system

providers. Furthermore, the willingness to pay for an added value/increased user experience is a revenue opportunity for both mobile network operators (MNOs), for being able to offer high-end subscriptions, and system providers (e.g., gaming/education providers), for being able to generate a more immersive experience based on increased network capacity. Some of the identified KVIs are shown in Table 6. For example, these new use cases require digital contents. As for the KVI, we expect there will be a massive new business opportunity for the content creators, platform developments on the education programme and interactive game content. In another example on AR navigation, efficient marketing communication serving consumer needs can be achieved as the consumer receives the requested information in a timely manner.

Table 6 summarises the main KVs, KVIs and example KVI enablers for the consumer use cases.

Table 6: Summary of KVI and its enabler of Consumer Subnetwork

KV	KVI	KVI Enabler (examples)
Social	<ul style="list-style-type: none"> • Improve social connection / interaction • Attract the pupils to join the education program and provide them easier access to the taught subjects. • Improve quality education • Reduce dropping rate of students 	<ul style="list-style-type: none"> • High data rate communications • Low latency and high reliability communications • Compute offload • Discovery of offload opportunities
Environment	<ul style="list-style-type: none"> • Reduce the transportation efforts • Lighter devices with less materials 	
Economic	<ul style="list-style-type: none"> • Create new business opportunity, such as content creator, platform provider. • Provide higher quality education at lower cost (unburden and enable teachers) • Create new job opportunities • Improve efficiency and productivity • Reduce inequality, by providing good education easier and cheaper. • Efficient marketing communication serving consumer needs 	

3.5 CONSUMER SUBNETWORKS USE CASES

In the following, the relevant identified use cases for consumer subnetworks are described. For each use case, we describe the elements that are used to implement the functionalities for the respective consumer services and applications. We also identify pre-conditions, the operational flow, and post-conditions when the use case is correctly implemented. Finally, we report the main potential key performance indicators and requirements of the use cases.

3.5.1 Immersive Education

3.5.1.1 Description

Education is a decisive task of society that crucially determines its future success. Immersive Education aims at enhancing the interactive experience of a group of students and teacher(s) for knowledge exchange, leveraging media content, and related technologies. It allows to enhance the students' experiences beyond an ordinary classroom. This will also help them to understand the course content more easily and intuitively so they can apply the classroom concepts in the practical world. As every student has a different learning style, providing a rich XR experience with various diverse stimuli will give the students a better chance to learn consistently. This not only fosters a healthy interaction amongst students in the classroom, but also aids a better integration of virtual students.

While education is primarily taking place in dedicated venues (classrooms), the concepts can be extended to field excursions, e.g., to historic sites, museums, industry venues and others, as well as on the go. The media to be shared include telepresence type of footage to allow interactive participation of remote students (or teachers). However, an important aspect is also to provide tutorial footage allowing an almost “hands on” experience for the students, ideally offering options for (virtual) interaction providing a “learning by doing” experience.

The immersive education use case can be further divided into a subset of use cases to serve distinct applications as there will not be a single application scenario covering all the related aspects. These applications will also differ depending on the devices that will be utilized. While it would be easier to implement use cases using dedicated and specialized devices, the option should be provided to use generic devices (that may be available to the students anyhow). This however requires dealing with a heterogeneous set of devices, both from student interaction and communication capabilities standpoint. Such heterogeneity will have to be supported by the subnetwork architecture and the protocols.

The strict latency requirements, the geographical area of communication, potential computation offloading, and the fact that the capabilities of devices may vary from simple displays over XR devices up to fully immersive holographic devices equipped with tactile sensors and actuators, requires more independent and hierarchical subnetworks.

There are many options for providing a functional split between the subnetwork devices and the content server, which may also include additional content and compute servers in proximity to groups of pupils. These servers belonging to the corresponding subnetworks close to the end devices can greatly offload the computational burden from the end devices and thus allow inclusive scenarios with a set of diverse devices. The operation of immersive education is illustrated in Figure 8, providing a general artist's view of the use case to illustrate the use case objectives while a more technical view is presented in Figure 9, which is focussing on the architectural components, functionalities, and relationships of the involved devices that collectively implement the use case within the subnetworks of the entity of the classroom.

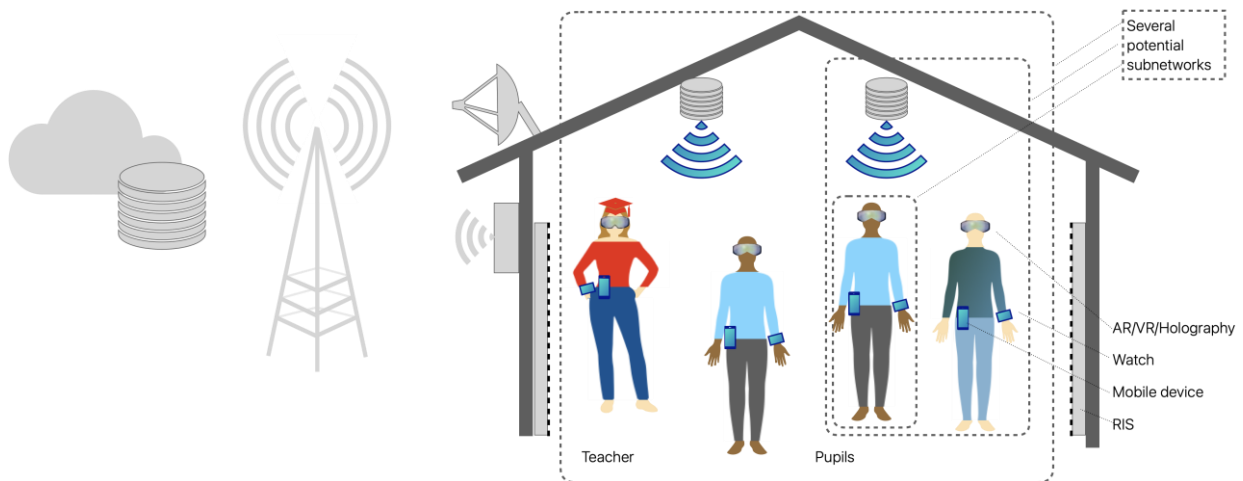

Figure 8: Illustration of immersive education showing some potential hierarchical subnetworks (adapted from [11])

3.5.1.2 Pre-condition(s)

Students (or pupils) have gathered in the classroom (or lecture hall) and have their devices ready. Optionally, some of the pupils or the teacher may join in remotely from another location (tele-education).

Devices may typically be XR devices, but optionally there could also be more advanced or less advanced devices ranging from ordinary screens or tablets (or cardboard-style smartphone holders, improving XR displays) up to holographic displays serving individual students or sets of students. The teacher has a similar device but with extended capabilities allowing to steer the lesson, supervise pupils' actions and provide dedicated support and feedback.

The footage has been made available in the local subnetworks, i.e., ideally within the classroom. Apart from the media content the provisioning of computational offloading, e.g., for animating the footage or offloading of Artificial Intelligence/Machine Learning (AI/ML) tasks may be beneficial to support a broad range of individual devices. This compute offload may be provided by the same devices within the local subnetwork, that provide the footage, it might be devices owned by pupils, the teachers or provided in the classroom or could alternatively be provided in the 6G parent network, e.g., on a close by edge server.

3.5.1.3 Operation Flow

The flow of operation can be described as follows:

1. Pupils have connected their devices to the local AP and are thus connected to the server hosting the session, either directly or indirectly via intermediate servers or access points within the subnetwork. The teacher has selected a session and is ready to launch and steer it.
2. Media content regarding the lesson is streamed from the respective local AP to the pupils' devices. The teacher can steer i.e., modify the lesson, provide additional explanations, and highlight interesting aspects. Typically, the pupils can also interact with the content and provide hints, such as, pointing at specific questions, which will be visible to the teacher and the other

pupils, when enabled by the teacher. Consequently, there is not only a stream of data from the local AP to the devices, but also in the other direction and between devices (potentially via the local AP).

3. Pupils may explore the subject on their own, looking at different aspects of the scene and exercising different details, either individually or in groups. During this stage, the experience of different sets of pupils may diverge due to their individual interests and learning pace.
4. Eventually, the session is wrapped up and finally terminated or replaced by a subsequent lesson by the teacher.

3.5.1.4 Deployment Scenarios

Typically, this use case will take place in an indoor deployment. It is assumed that there is a 6G parent network providing connectivity and internet access as well as potentially additional compute capabilities at the edge or in the cloud. Within the subnetwork there might be other higher capability devices, e.g., more powerful laptops, computers, or even high-end phones that provide additional computational and communication capabilities.

A special variant are field excursions, which may go into dedicated venues like museums that will be similarly equipped as classrooms or may even have more advanced equipment. At those venues it should be possible to integrate these on-site facilities quickly into the class's subnetwork.

In case the excursion goes outside, i.e., into an area without such supporting equipment, then it should be possible to operate autonomously for some time, based on footage and compute resources available in the subnetwork itself. Whenever available, the 6G parent network can provide connectivity and provide additional compute resources at the edge. This may be a special use case, sharing some characteristics with the AR Navigation use case. Depending on the local connectivity and the number of pupils, it may be necessary to scale down the visual quality, or the complexity of the use case, to bring traffic and compute demand in line with the one available in the respective locations.

3.5.1.5 Subnetwork Architecture

An exemplary architecture diagram for the use case is shown in Figure 9. It contains multiple subnetworks (SN) spanning the devices of individual pupils or the teacher. These subnetworks may be composed of several devices (HC and LC), which may include XR headsets or supporting compute nodes which may e.g., be implemented within or together with UEs or computers. Additional sensors (SNE) may provide additional information e.g., pose related, within these subnetworks. The HC devices will control the personal subnetworks (SNM) and the connections therein (RRM), may provide locally compute power to offload compute (OFF) and provide connectivity (GW). Subnetworks may be nested and share the connectivity through a single HC as shown in the green subnetworks (SN). Ideally subnetworks contain powerful compute nodes supporting rendering tasks (see HCs with offloading capabilities OFF), they can be organized in a dedicated subnetwork, or as part of subnetworks, shown as HC devices below. Each subnetwork is controlled and connected via an HC device. Together they form a classroom entity (EN) that is connected to the internet and external servers hosting the desired footage

via the 6G parent network (6G BS). This 6G parent network may additionally provide compute resources (CompN) located at the edge, or further in the core-network (6G CN).

Optionally, one or several Reconfigurable Intelligent Surfaces (RIS) may be deployed to enhance communication with and within the subnetworks and extend coverage.

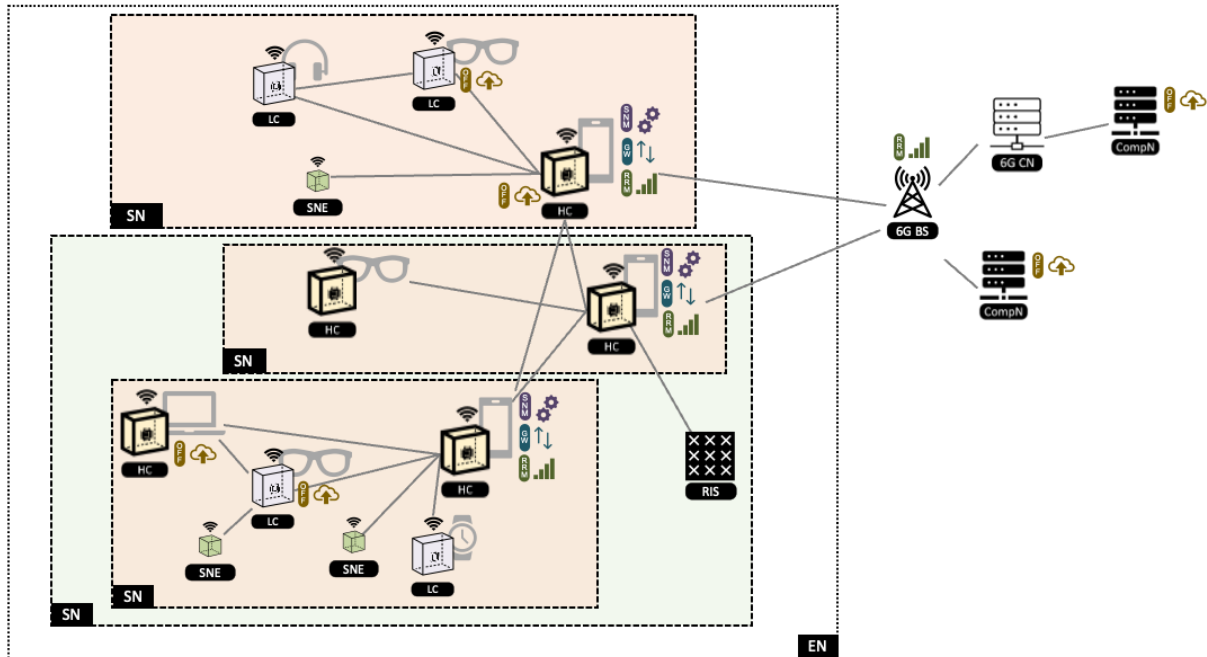

Figure 9: Subnetwork Architecture of the Immersive Education Use Case

The main functional requirements to support the subnetwork architecture of the immersive education use case are listed in Table 7, together with short explanations of these functionalities.

Table 7: Functional Requirements of the Immersive Education Use Case

ID	Functional Requirement
C-1-FR-1	The HC and LCs shall be able to discover each other in the initialization phase. Devices shall be able to form subnetworks, where HC devices shall be able to take the role of subnetwork management nodes.
C-1-FR-2	The HC heading a SN shall offer access to the SN to authorized users (i.e., pupils) and allow the teacher to do (or have done) suitable configurations. The HC device heading a SN shall offer access to the SN to authorized users (i.e., pupils) and allow the teacher to do (or have done) suitable configurations.
C-1-FR-3	The HC shall be able to determine and establish suitable connections to and between the LCs and HCs, in particular, to those offering compute offload.

	HC devices shall be able to offer additional capabilities to LC devices (e.g., compute power, connectivity).
C-1-FR-4	The HC shall be able support discovery of external compute offload options (e.g., edge or within the parent or 6G network) and provide their service to LCs. Devices in the subnetwork shall be able to discover additional capabilities provided by devices within the subnetwork, neighbouring subnetworks, or edge/cloud.
C-1-FR-5	This configuration may need to be adapted to varying circumstances, e.g., availability of HC devices, number of pupils and the (traffic & compute) characteristics of the lesson. Subnetworks and their managing HCs shall be able to adapt to changing requirements (e.g., number of pupils, characteristics of the lesson) and/or physical distribution of devices and adapt subnetwork topology.

3.5.1.6 Post-condition(s)

Each pupil has experienced an immersive education session and gained insight on the taught subjects, tailored to the user device, and adapted to the individual experience level. The teacher was able to assess pupils' paces, interact with them, and steer the session accordingly.

3.5.1.7 Challenges to the 6G system

The main challenges are:

- To support the necessary connectivity for a suitable immersive education experience to a set of users, either within the same classroom or distributed over a wider area. Particularly the real-time nature that requires a low delay to provide instantaneous response upon user interactions will be challenging. The locality and density of devices communication at a low latency scale may require more communication happening locally and thus being ideally managed locally within the respective subnetworks.
- Offloading of the computational efforts from the devices towards an AP or server is a promising technology enabling slim user devices. Unfortunately, this comes at the cost of increased communication load and more strict latency requirements to provide properly pre-processed footage at the right time to the respective devices. There are various strategies available for the local compute vs. communication trade-off. As a general rule, the better the communication the higher the potential for computational offloading and consequently lower complexity and power consumption on the user devices. Accordingly, there is no fixed set of KPIs that enable the use case, but any improvement of the communication KPIs can be leveraged in favour of supporting slim devices and extended device battery longevity.
- Heterogeneity in the devices may necessitate different approaches for the individual devices with tailored trade-offs between computation and communication. To select the proper split of streams for individual and joint footage, the 6G system and the application should be able to

determine and adapt to the possible aggregate communication rates for optimal selection of the individual media encoding schemes.

The above challenges may not be able to be fulfilled by the existing 5G technology. We consider the following selected technology components (TCs) shown in Table 8 are highly relevant for this use case.

Table 8: Selected Key TCs for Immersive Education Use Case

Technology component (TC)	Explanation
TC1. In-X data traffic models	General aid for developing a concept
TC2. Channel models for in-X scenarios	General aid for developing a concept
TC3. Sub-THz system models	Sub-THz transmissions are a promising technology to provide ample capacity for multiple users closely localized and enable short frame durations to support ultra-low latency and high reliability in suitable propagation environments.
TC4. Ultra-short transmissions with extreme reliability	Small latency enables more options for offloading within the subnetwork, while this use case may not require extreme reliability.
TC5. Analog/hybrid beamforming/beamfocusing	Enable optimized communication with individual devices or groups of devices within the coverage area of a particular subnetwork and increase overall capacity
TC7. RIS enhancements	Enable steering of beams towards individual users within a room
TC8. Intra-subnetwork macro-diversity	E.g., to achieve reliability for low latency
TC9. Flexible/full duplex scheduler	Depending on the selected offloading scheme for Uplink (UL) and Downlink (DL) related processing, there may be both significant uplink and downlink traffic, which is the scenario benefitting most from flexible/full duplex scheduling options
TC10. Predictive scheduler	Prediction helps optimize compute vs. communication (e.g., radio resources) trade-off
TC11. Latency-aware access in the unlicensed spectrum	Optimized latency in unlicensed spectrum enables more options for offloading within the subnetwork
TC13. Distributed/hybrid radio resource management.	E.g., distributed within the subnetwork
TC15. Hybrid management of traffic, spectrum and computational resources	There is a trade-off between communication and compute when deciding about offloading strategies for the provisioning of multimedia content, e.g., rendering. To find the optimum setting and to maintain it despite variations in connectivity and compute demand requires an

	integrated approach to scheduling and resource management.
TC16. Coordination of operations among subnetworks in the same entity	If multiple subnetworks within a location e.g., the classroom serve the users, potentially via multiple local or edge servers, and considering that the subnetwork may be built from a hierarchy of personal subnetworks that aggregate each user's set of devices, this will be very relevant

3.5.1.8 Traffic Characteristics

Typically, the traffic will be dominated by video and audio traffic, plus the supportive pose information for generating video footage from proper viewpoints. We expect similar traffic patterns as exemplified in the indoor interactive gaming use case and as set out in [13], and similarly in [3] and [14]. However, it should be kept in mind, that these traffic characteristics target today's implementations. Going forward, we may want to enhance resolution and vividness of the user experience, requiring higher data rates, roughly in proportion with the quality enhancement.

Note: Traffic is expected to be similar to indoor interactive gaming, also somewhat similar to virtual content creation, though the latter will likely target higher quality for production even if it might be scaled down as needed for distribution.

3.5.1.9 KPI Aspects & Requirements

XR immersive education will have certain network traffic characteristics, in particular, considering the interactions of multiple pupils and provisioning a suitable footage from a server. For the latter, [14] quotes a wide variety of KPIs depending on the selected compute architecture split. Required latencies are ranging from several 10s of milliseconds down to a few milliseconds, and data rates from few Mbps up to multiple Gbps. Typically, at least the high-end values cannot be achieved for 5G networks, when required for several devices within a constrained area. We expect that advanced communication schemes within subnetworks to be developed within 6G-SHINE will allow to reach such challenging requirements and benefit from device offloading, enabling the utilization of lean devices. Well-coordinated subnetworks will ease signal processing for all the involved devices by mitigating intra subnetwork interference. Basically, the better the communication the less effort for local compute is required. Multiple pupils often view highly correlated content, consequently, precomputing and distributing pre-processed content via broadcast or multicast towards multiple devices allows to benefit the reduced device complexity for multiple devices.

Data rate

Data rate estimates will need to include peak data rate, and typical data rate, both for individual devices and for multiple devices as immersive education is typically a multi-user scenario.

Latency

Considering end-to-end latency, we may need to not only consider communication latency (including retransmissions when necessary), but also the latency for distributed processing that is required both at the end devices and the server and potentially intermediate servers or supporting devices. Note that the configuration of dynamic subnetworks may also contribute to latency. Consequently, this aspect should be investigated and optimized suitably.

Synchronization

Different users' experiences and reactions need to be processed in a well synchronized way to allow a coordinated and responsive immersive experience of multiple users.

Maximum Number of Users

The number of pupils to be supported needs to cover the respective class. Depending on local situations this may be from the low tens of pupils for a typical classroom up to thousands of pupils in specific cases of large lecture halls. Potentially, for fully distributed scenarios linking pupils from multiple sites to a teaching session, the number may be even higher, but this may be considered a specific variant of the use case.

Reliability

At this use case does not involve critical operations, the reliability does not need to be extremely high in comparison to some other use cases. However, losses in data should not cause annoying effects like display artefacts or rough motion, which may be tolerable in rare cases but would deteriorate the user experience when happening too often. The occurrence of such artifacts should be seldom enough, e.g., happen much less than once during a typical lesson on average. While some data loss may be hidden by error concealment strategies, those would increase local compute requirements if they should cover more substantial data losses (e.g., bridging more than just a few frames).

The expected requirements of the above KPIs for immersive education is expected to be similar as the requirements for indoor interactive gaming (See section 3.5.2.9).

3.5.2 Indoor Interactive Gaming

3.5.2.1 Description

This use case is about XR interactive gaming in an indoor environment where one or more players play in a controlled environment. A controlled environment is a place equipped with some equipment to facilitate the XR interactive gaming. For example, various sensors and actuators have been placed in certain strategic locations, the high capability element acts a similar function as access point and its antennas are placed in optimal location, and a high-end edge server is located or attached together with the HC. A controlled environment is likely an indoor area / a room dedicated for this use case. Figure 10 illustrates the scenario of indoor interactive gaming within a subnetwork. Here, there are two game players, each of them is wearing various types of devices:

- VR headsets
- small sensor and actuator devices attached to the body.

The tracking of headsets could be both outside-in or inside-out, where the outside-in tracking is the external sensors (like base stations) placed around the VR headset to track the movement of the users while the inside-out tracking is the embedded sensors (like cameras) placed on the headset or controllers to track the movements of the users. Based on the setting of the indoor environment, the outside-in type tracking is more suitable for this scenario.

The indoor environment is equipped with many static sensor devices which are scattered around the room. These sensors are used to obtain user(s) poses / orientations and then later to be used for the XR scene generation. All those sensor devices can communicate locally to an HC within a subnetwork. There is also an edge server that can be built-in to the AP or separately.

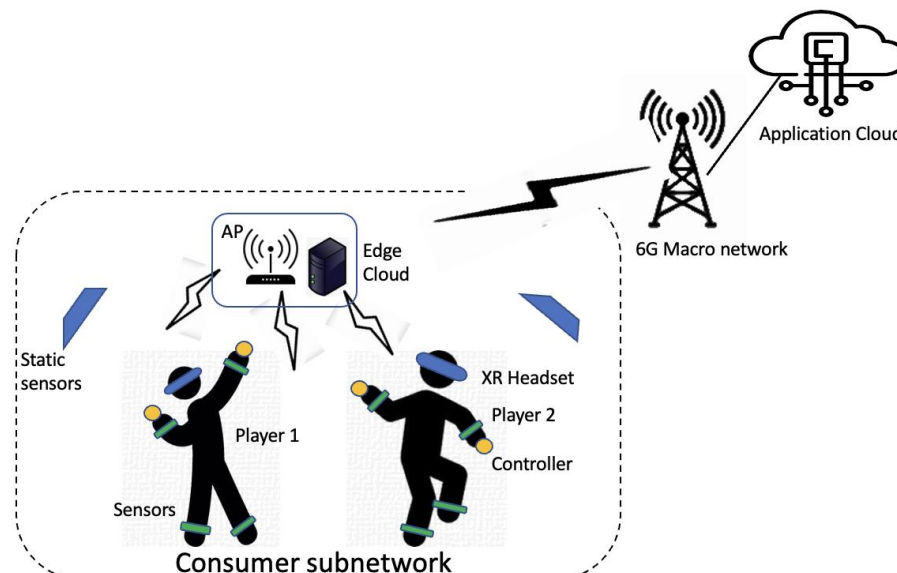

Figure 10: Illustration of indoor interactive gaming within a subnetwork

The game, obtained from the application cloud server, is preloaded into the edge server. The edge server provides the XR scene to the VR headsets based on the input from the camera attached to the VR

headsets and various sensors (e.g., in the VR headsets, attached in the room, and attached to the users). The XR scene can be produced in the edge server so that it will minimize the computation process in the VR headsets itself. This process is known as split-rendering operation. There are also another options where the VR headset has high capability computation so that the XR scene can be self-generated. However, it may also increase the VR headset power consumption.

In order to provide immersive XR experience, the edge server could provide input to the device attached to the users (i.e., actuators) so that the game player experiences sensation of the game in a form of, for example, vibration, heating. This sensation inputs shall be synchronized with the XR scene delivered to the game player. Furthermore, the XR experiences (e.g., XR scene, sensation) shall also be synchronized among all the game players.

3.5.2.2 Pre-condition(s)

Game participants are wearing the VR headsets and are equipped with sensors which are attached to their bodies.

The indoor environment is equipped with an AP which is connected to the 6G macro network, then to edge cloud server. In addition, certain rooms within the indoor environment are equipped with static sensors.

3.5.2.3 Operation Flow

The flow of operations events can be described as follows:

1. The game player(s) select the game from the application server and downloads it to the edge server.
2. The edge server provides the XR scene to the game player(s) (e.g., the VR headsets attached to the game player(s)).
3. The sensors, including camera attached to the VR headsets provide the input to the edge server. Those sensors detect the head movements and also capture the image surrounding the game player.
4. The sensors attached to the game player (e.g., sensors in hands, legs) detect the body movements and send the output to the edge server.
5. The sensors in the room also detect the player(s) movement and send the output to the edge server.
6. Based on 3), 4), 5), the edge server processes the XR scene and provides the XR scene to the game player (step 2 above).

3.5.2.4 Deployment Scenarios

One of possible deployment scenarios for indoor interactive gaming is similar to indoor hotspot as described in [15]. The size of indoor area is scalable depending on the purpose. It can be a large hall, such as a commercial indoor gaming area. Alternatively, it can also be in a room, such as a living room for a private indoor gaming arena. One or multiple indoor High Capabilities element(s) with a similar

function as a base-station with small coverage are located in the indoor area. In case of multiple HCs, at least one of the HC(s) is connected to the 6G parent network. For example, the HC is connected to 6G base-station located in outdoor (e.g., macro base-station).

For the devices, the user with XR devices (e.g., VR headset) which can be categorized as LC or HC element. There are also sensors and actuators (categorized as SNE) located in indoor area. In principle, we consider a 100% indoor user distribution. The user is expected with low mobility, such as with the speed 3 kmph or less. Within an indoor area, the number of users with XR device can be up to 10 users depending on the size of the indoor gaming arena. Furthermore, there are approximately up to 100 sensors and actuators.

The devices are expected to be connected to one of the HC which act as a base-station or access point. The operating frequency can be within FR1, FR2, or any other potential new frequency range (e.g., sub-THz). For example, FR2 which has wider bandwidth (e.g., 1 GHz bandwidth) is used to provide high data-rate for the connectivity to the XR device. FR1 can be used for the connectivity to the sensors and actuators. In order to improve the link quality in certain area, RIS panel can be deployed in the area.

3.5.2.5 Subnetwork Architecture

An architecture diagram for the indoor interactive gaming use case is shown in Figure 11. In this figure, we consider two users equipped with XR devices (e.g., headset). One XR device is represented as an HC element. The XR device has high computation function so that it can locally generate the XR viewport rendering based on its own sensor and controller input. The sensor and controller can be in a form of SNEs. The other user is equipped with an XR device as an LC element. It does not have high computation function so that it performs split rendering process in order to generate the XR video at the game player display. The LC receives the sensors' and controllers' information from SNEs attached to the game player. The information is transmitted by LC to the AP (another HC element). HC element that has AP functionality here has even higher capability than the HC for XR device. It performs various roles such as gateway role, RRM role, offloading role. The offloading role would enable the AP to perform as XR engine to generate the XR scene for the XR device with LC element. The HC as an AP is also connected to other XR devices with HC elements, SNEs representing sensors, controllers, and actuators. The HC can be connected to a 6G BS, that can manage radio resources among other subnetworks. The 6G BS is connected to the CN as well as to a CompN, that can take care of computational tasks related to the resource management of the subnetworks in the coverage area of the parent network. The subnetwork can also optionally be equipped with a RIS element to improve the signal reception in certain areas.

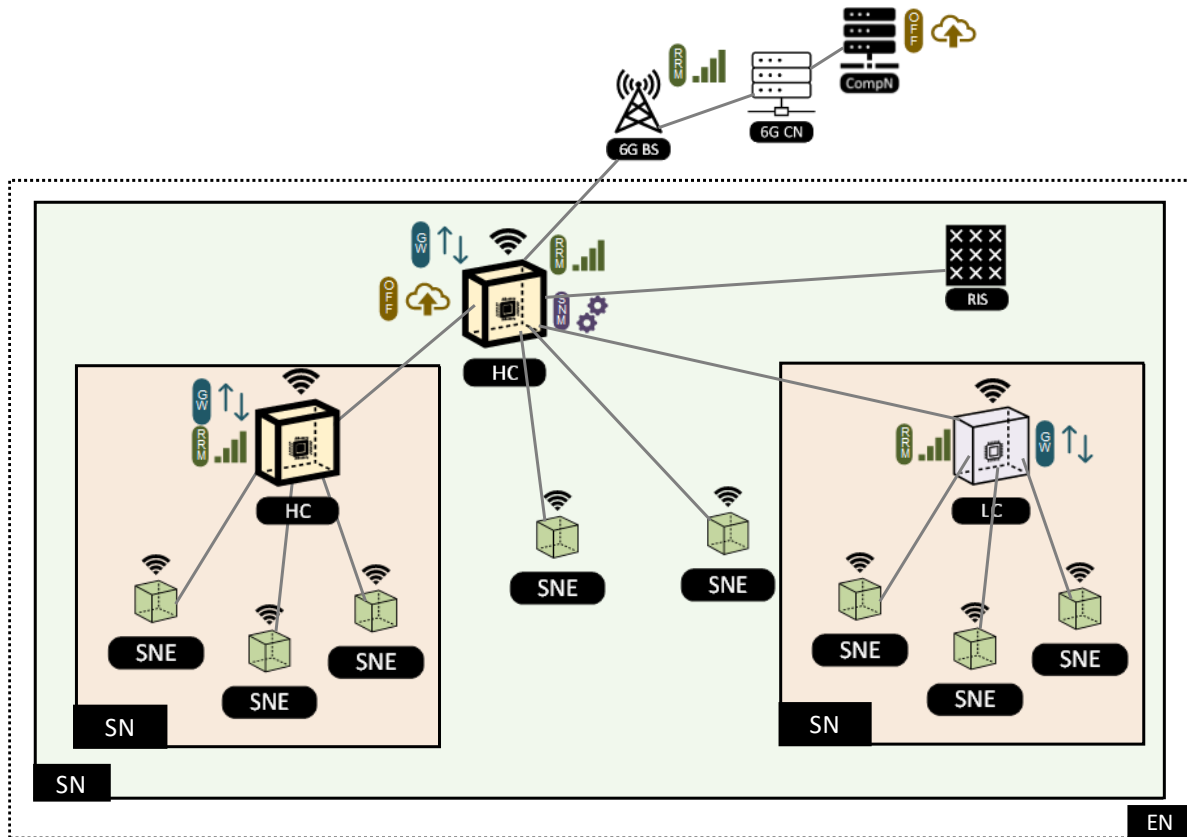

Figure 11: Subnetwork Architecture of the Indoor Interactive Gaming Use Case

The main functional requirements to support the subnetwork architecture of the Indoor Interactive Gaming use case are listed in Table 9.

Table 9: Functional Requirements of the Indoor Interactive Gaming Use Case

ID	Functional Requirement
C-2-FR-1	In the initialisation phase, the system shall enable the devices (SNEs, LC, HC) to register, transfer capability to at least one of the HC.
C-2-FR-2	The system that is managed by at least one of HC acts as an access point / base station shall be able to operate in stand-alone and/or connected to the 6G parent network.
C-2-FR-3	The system shall support highly time-sensitive network (e.g., among SNEs, LCs, HCs) to achieve certain QoS.
C-2-FR-4	The system shall support computation offloading/distribution function (e.g., to support XR split rendering operation)

3.5.2.6 Post-condition(s)

Each game participant is wearing VR glasses that provide full immersive experiences during game playing. The light weight of the glasses guaranties that players can wear them during the duration of the game session and feel comfortable.

3.5.2.7 Challenges to the 6G system

The XR interactive gaming as described above requires massive communication links between the sensors and the edge server, XR scene processing, and the transmission of XR scene from the edge server to VR headsets and devices attached to the users. All of these operations shall be executed in a very limited time in order to provide a high quality XR experience. The main challenges are:

- To provide various sensors outputs from multiple nodes in a synchronized manner
- To provide the scenes and information for different users in a synchronized manner
- To provide ultra low latency and high reliability communications
- To provide high data rate communication (i.e., providing XR scene to the users)

The above challenges may not be fulfilled by the existing 5G technology. A 6G system with subnetwork operation is expected to overcome those challenges. A subnetwork that is operated within a close proximity (less than 10 meters) can ensure extremely low latency and high reliability communications, particularly for high data rate communications. The usage of RIS is expected to have an important role in increasing the performance of radio communications. The RIS panel(s) can be strategically placed in certain locations of an indoor XR gaming area.

The following highly-relevant technology components (TCs) are considered for this use case. Other TCs can still be relevant and are shown in section 3.6.

Table 10: Selected Key TCs for Indoor Interactive Gaming Use Case

Technology component (TC)	Explanation
TC3. Sub-THz system models	Indoor gaming, especially in small room, makes it feasible to operate the wireless communications with sub-THz frequency in order to provide high data rate and ultra-low latency communications.
TC4. Ultra-short transmissions with extreme reliability	Ultra-low latency with high reliability improves the user experience.
TC5. Analog/hybrid beamforming/beamfocusing	Enable optimized communication with individual devices or groups of devices within the coverage area of a particular subnetwork and at the end the overall network capacity.
TC7. RIS enhancements	Enable reflecting radio signals towards individual users within a room
TC15. Hybrid management of traffic, spectrum, and computational resources	Enable the efficient resource allocation and distributing the computational resources in various nodes.

3.5.2.8 Traffic Characteristics

XR processing and media architecture for 5G system has been studied and described in [14]. Specifically to this use-cases, it will involve the data traffics from XR server which is basically the game server to the XR device. The data traffics may include video, audio, and data/control information. One of the most

challenging parts is on handling the XR media traffic which would be typically the video streaming. In one of the architectures, the XR scene displayed on the end-user XR device during the operation of indoor gaming, can be generated in the XR device itself. This operation may not require extensive media streaming to the XR device. Consequently, the XR device requires a high processing unit to generate the XR scene with certain video quality and latency requirements. The high processing computation could quickly drain the battery. Furthermore, high processing computation may also cause excessive heating dissipation in the device (overheating). It can make a discomfort feeling to the end user.

In another architecture, the XR scene is generated in the game server and then the outcome is transmitted to the XR device. This operation, known as split rendering, may not require XR device with high computation power and it can extend the XR device battery life. We are interested to explore this architecture, including the traffic characteristics. The operation of split rendering between game server and XR device is illustrated in Figure 12. This figure is the modified version of the cloud gaming operation in 5G system described in [13].

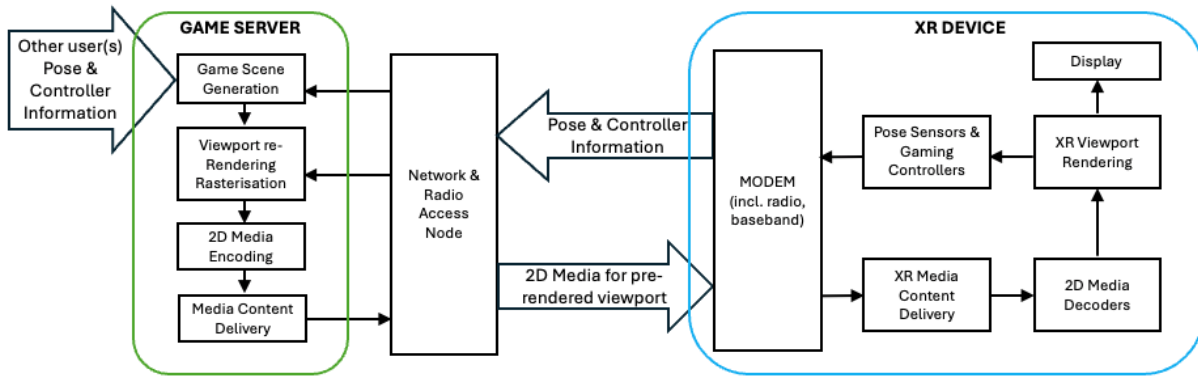

Figure 12: Split Rendering Operation in Cloud Gaming

The same principle as described in [13], the game server runs a game engine to generate the game scene based on the input, such as pose and controller information from the game player. There could also be other inputs, such as the other user(s) that can be co-located with the indoor game player or be at other places connected via internet cloud. The game server rasterizes the viewport and performs the scene pre-rendering. The output is encoded with 2D media encoding. The media content delivery provides the output from the game server that can be transmitted to the communication system (e.g., 6G system). The communication system here includes core network node(s) and base-station(s)/access point(s). The access point in this context can be the high capability (HC) element as described in Chapter 2. The AP transmits 2D media for pre-rendered viewport to the XR device. The wireless transmission is received and processed by the communication module (e.g., modem part) of the XR device. The XR device performs 2D media decoding and XR viewport rendering prior to providing the XR scene to the game player's XR display.

The traffic under consideration includes both downlink and uplink transmissions between AP and XR device. The downlink transmission includes 2D media for pre-rendered viewport, audio, and data. The

uplink transmission includes pose and controller information, audio, and data. The 2D media for pre-rendered viewport can be categorized as the video frames. The generated video frames can be related to the video games characteristics. The most challenging video games characteristics apply for games that require content that is photo-realistic or based on natural images/video. It may require a spatial resolution up to 3840 x 2160 pixels, frame rates up to 120 Hz, and bit depth of 10 bits [13].

As part of the split rendering process in which the generated video frame depends on the uplink transmission containing pose and controller information from the user(s), round trip interaction delay is an important traffic characteristic. The components contributing to the round trip interaction delay, such as the encoding/decoding the video, transmission of the video frame to XR device, are described in [13]. Placing the game server co-located with the AP could reduce the transmission delay in the network side.

The traffic model for cloud gaming in 5G system is described in [3] and it shows the required data rate for the downlink transmission is up to 45 Mbps, the frame rate can be 60 fps, and packet delay budget 10 ms. A frame, particularly with a large video frame, may require multiple transport block transmissions in lower layers. The uplink transmission for pose and control information typically comes with transmission periodicity of 4 ms with packet size of 100 bytes. We consider the traffic amount to support XR applications can be scaled-up to anticipate higher resolution video transmission, higher frame rates, and other configurations to enhance the user experience which may be required in the future.

3.5.2.9 KPI Aspects & Requirements

XR interactive gaming may have certain network traffic characteristics. For example, the sensors' outputs from the user(s) and static sensor(s) in an indoor gaming area as the input for XR scene process. In another example, the video, audio, sensors' outputs generated at the edge server transmitted to the user as part of the generated XR scene.

1. The sensors for the XR scene generation.
Typically, low data rate, mixture of periodic and aperiodic transmission. There can be multiple sensors for such XR scene generation. These can be the sensor(s) that are statically placed in specific location(s) or attach to the user(s).
2. XR scene video
High data rate is required to ensure high quality video (e.g., wide view with 24K video quality), and the payload size may vary a lot (e.g., due to changing scenes).
3. XR scene audio
High quality audio, but it is expected the same audio quality as we have today (e.g., in 5G)
4. XR scene actuators to create immersive experience.
Typically, low data rate, mixture of periodic and aperiodic transmission. Multiple actuator(s) can be placed either static in certain locations (e.g., to blow wind) or attach to the user(s) (e.g., to feel the warm, punch).

The requirements to support the use case can be defined based on the KPIs as described in section 1.3.2. For the existing 5G system, 3GPP has performed a study and identified the traffic model parameters for

cloud gaming (CG) use case which is relevant to this use case [3]. It has been identified that for the video streaming, the default packet rate is 60 frame per seconds (fps), the average data rate is 30 Mbps. For the motion/control of the user, the packet rate is 250 fps with the average data rate of 0.2 Mbps. For the audio/data, the average data rate is 1.12 Mbps. As for the latency, a parameter, called as packet delay budget (PDB) is used. The PDB is 15 ms.

For the 6G use cases, we consider the requirements are expected to be much more stringent to fulfil the service requirements of this use case. The following are the potential KPI and requirements of interactive indoor gaming use case:

Data rate

We need to anticipate the required data rate to support the use case, including peak data rate, and user experienced data rate. Peak data-rate can happen when there is a sudden scene-change during the game. The entire video frame containing the main object and its background must be refreshed and transmitted. User experienced data rate varies, mostly depending on the transmission types (e.g., video, audio, or control/data). The data rate requirement can be the required bit rate to deliver certain video coding. ACV and HEVC are the prominent video codecs. ACV may require up to 150 Mbps to deliver 8k high quality video streaming. There are also multiple sources that have investigated the required data rate for XR applications, including indoor gaming [16], [18], and [19]. According to [16], a required user experienced data rate of up to 100 Mbps for a single user is expected. The user-experienced data rate depends on the expected user experience levels (Entry-Level VR, Advanced VR, Human Perception, Ultimate VR), in which the single-eye resolution, Field-of-View, video resolutions are different, and video compression technique [19]. The target streaming data rate for 5G or beyond is expected from 100 Mbps to a few Gbps depending on the required quality and operation [18], [19]. Ultimate VR with full video 24k quality, high refresh rate, and with lossy compression requires 6.37 Gbps [19].

Latency

We can firstly consider end-to-end latency. Furthermore, we need to break-down between communication latency and processing latency which may occur in various levels (lower / upper layer) and nodes (e.g., terminal, AP, base-station, core network node, etc). There are multiple sources that have investigated the required data rate for XR applications, including indoor gaming. According to [16], the maximum allowed end-to-end latency is between 10 – 20 ms. For example, for smooth experience in VR, the motion-to-photon latency should be less than 20ms [16], which indicates that the latency between a player's movement and the corresponding new pixels show in VR sights should be less than 20ms. The round-trip interaction delay, as mentioned in section 3.5.2.8, affects the motion-to-photon latency. In order to avoid motion-sickness, the motion-to-photon latency shall be less than 20 ms [17]. The latency target for 5G or beyond is 1ms over-the-air latency, which enable near-real-time experience and the motion-to-photon latency is expected to be 2-10ms [18].

Reliability

High reliability in the context of packet transmission reliability is important for indoor gaming use-case, particularly to avoid transmission failure, which could trigger packet retransmission and increasing the total transmission latency. The process of video encoding and decoding may involve multiple data

transmissions. Transmission failures may adversely affect the video decoding process. Transmission failures trigger retransmission processes which may cause increasing the latency. Long latency may cause the received retransmission data to arrive too late so it cannot be processed in the video decoding. Hence, the entire video frame cannot be decoded. This may cause video scene imperfection and reducing user experience. The required reliability can be up to 99.999% [16].

Synchronization

Simultaneous transmission within a limited time window from the end-user needs to be supported. The user is expected to transmit video frame (captured from the camera(s)), audio (from microphone(s)), and sensors. For XR gaming, the expected required synchronization varies depending on the type of transmissions, such as audio, video, or control / data. According to [16], the maximum synchronisation threshold (express in delay) for video (visual), audio, and control/data (tactile) are 15ms, 50ms, and 25 ms, respectively.

Maximum Number of Users

The relevant measure is the number of users that can be supported and satisfied with the expected XR experience. This may include the number of users connected to an HC element or the number of users connected to a 6G base-station, depending on the scenarios. For XR gaming, we consider the system can support up to 10 users connected to an HC element. High data rate transmissions with low latency are expected to deliver XR services to those users. Additionally, up to 50 sensors/actuators can be connected in a subnetwork.

3.5.3 Virtual content production of live music

3.5.3.1 Descriptions

This use case is about virtual content production of live music. Performers produce 3D video content that can be delivered live or uploaded to social media. Performers in different locations perform live together. To create 3D video content, multiple professional cameras (e.g., 4K cameras) and multiple microphones are used in each indoor room (e.g., live studio) where one performer performs. Audience in different places far from the live studio (e.g., their home) can view content at different angles of the production by using XR device. Figure 13 illustrates the scenario of virtual content production of live music supported by a subnetwork. This illustration shows two performers, and each performer is in a different live studio. In the live studio, 360° cameras and 360° microphones are installed and connected wirelessly in the subnetwork. Video and audio data from 360° cameras and 360° microphones are sent to content processing server. Content processing server creates 3D video content. To enable performers to act in a well synchronized way, the content processing server sends feedback function (e.g., feedback via monitor and earphone) to each performer via monitor and earphone. The feedback video and audio data, that shows and hears their own performance, is used for checking their synchronized performance in real time. The content processing server sends the 3D video contents to remote live audiences or uploads 3D video contents to cloud servers (e.g., social media) for later viewing. The post-processed 3D will show one or multiple of the performers video.

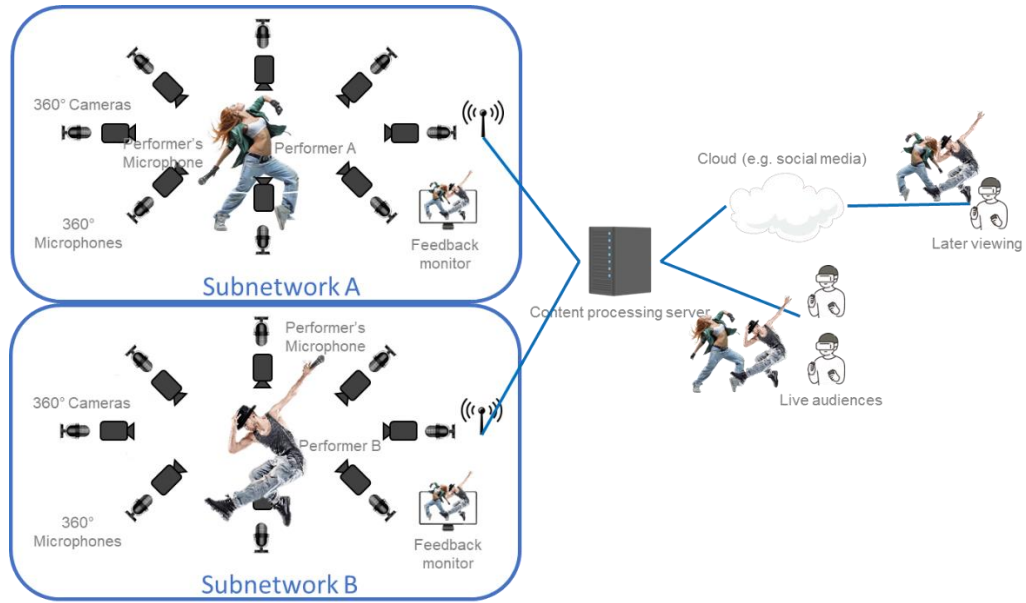

Figure 13: Overall Description of Content Production of Live Music

3.5.3.2 Pre-condition(s)

Multiple professional cameras and multiple microphones are installed in a live studio where performer(s) will perform and are connected wirelessly with the respective subnetworks. The performer(s) in different geographical location is(are) equipped with similar installations.

3.5.3.3 Operation Flow

The operation flow of this use case is described as follows:

1. The performer(s) starts to perform their live music (i.e., singing, dancing) in the live studio.
2. Multiple professional cameras and microphones record video and audio of their performance.
3. The multiple professional cameras, microphones, and sensors send these data (i.e., video, audio, and pose/control) to content processing server.
4. The content processing server creates 3D video content that the performer(s) performs in the live studio virtually together.
5. The content processing server sends the feedback data to each feedback function (monitor and earphone).
6. The content processing server broadcasts the 3D live video contents to live audiences or uploads to cloud servers for later viewing.

3.5.3.4 Deployment Scenarios

The deployment scenario for virtual content production of live music is similar to the indoor gaming scenario as described in section 3.5.2.4. However, the number of actuators can be limited. The data traffic will be dominated by uplink transmission from each subnetwork to the content processing server

via 6G parent network. The content processing server can be co-located in 6G core network or in the cloud as an application server.

3.5.3.5 Subnetwork Architecture

An architecture diagram for the virtual live production use case is shown in Figure 14. Here, we illustrate a subnetwork with an HC acting as an AP. The HC is connected to various SNEs as the sensors/actuators and also LCs which typically are the video cameras capturing the artist(s) performance. The subnetwork can also be optionally equipped with RIS element(s) to improve the signal reception in certain areas. The 6G BS is connected to the CN as well as to a CompN, that can take care of computational tasks related to the resource management of the subnetworks in the coverage area of the parent network. It can also carry application specific functions such as editing/combining multiple streams from different subnetworks that can be co-located or in different geographical areas.

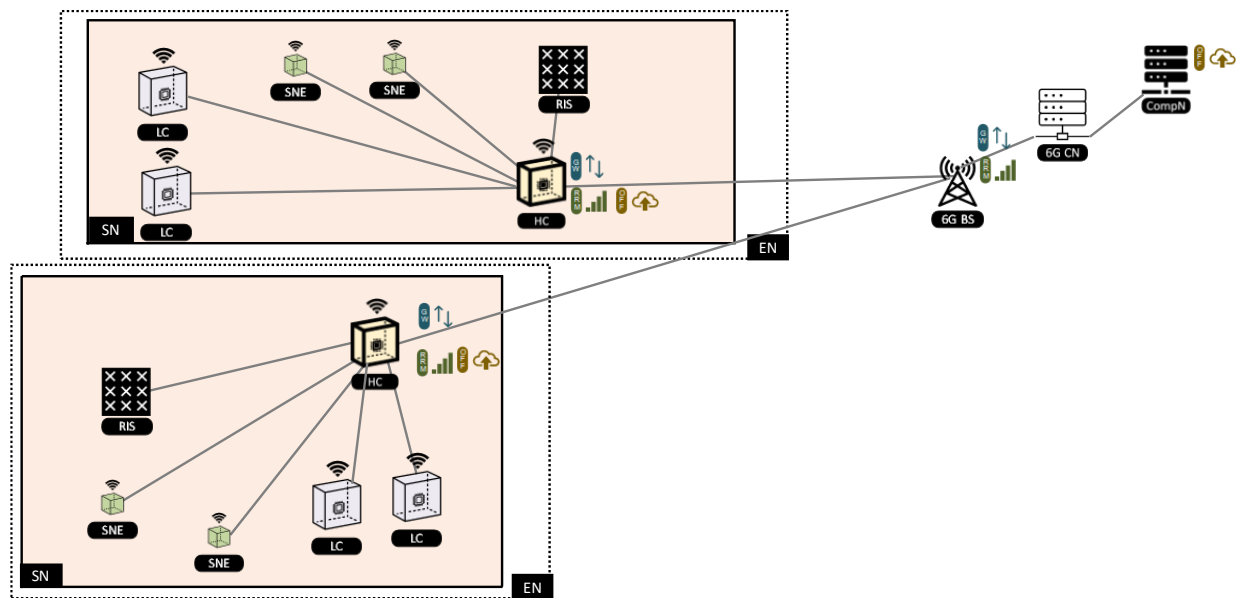

Figure 14: Subnetwork Architecture of the Virtual Live Production Use Case

The main functional requirements to support the subnetwork architecture of the virtual live production use case are listed in Table 11.

Table 11: Functional Requirements of the Virtual Live Production Use Case

ID	Functional Requirement
C-3-FR-1	In the initialisation phase, the system shall enable the devices (SNEs, LC, HC) to register, transfer capability to at least one of the HC.
C-3-FR-2	The system that is managed by at least one of HC acts as an access point / base station shall be able to operate in stand-alone and/or connected to the 6G parent network.

C-3-FR-3	The system shall support highly time sensitive network (e.g., among SNEs, LCs, HCs) intra and inter entity(ies) to achieve certain QoS.
----------	---

3.5.3.6 Post-condition(s)

1. The audiences can have immersive experience of remote live music in different places.
2. The performers can perform in different places.
3. The operator of live music can easily set up the environment of live music since the system is operated wirelessly. Wiring installations (and possible removal) can be avoided.

3.5.3.7 Challenges to the 6G system

To provide immersive experience of live music, extremely high data rate is required to send video data from multiple professional cameras to the content processing server. In addition, to enable synchronized performance, low latency feedback to each performer is necessary.

It is difficult to meet the above requirements by using the existing 5G. A 6G system with subnetwork is designed to meet the requirement of this use case as the 6G system will support various aspects, such as high data rate with ultra-low latency, synchronisation of many different network elements, computation offloading function, etc.

The following highly-relevant technology components (TCs) are considered for this use case. Other TCs can still be relevant and are shown in section 3.6.

Table 12: Selected Key TCs for Virtual Content Production Use Case

Technology component (TC)	Explanation
TC3. Sub-THz system models	To provide ultra-high data rate, operation with extremely wide bandwidth would be required. Sub-THz would be one of options to easily allocate such wider bandwidth.
TC4. Ultra-short transmissions with extreme reliability	Ultra-low latency with high reliability improves the user experience.
TC5. Analog/hybrid beamforming/beamfocusing	Along with operation with extremely wide bandwidth, advanced beamforming/beamfocusing technology would be beneficial to improve spectrum efficiency. Analog/hybrid beamforming/beamfocusing using massive antennas and/or multiple transmission/reception points would contribute to achieve ultra-high data rate.
TC7. RIS enhancements	Since this use case is mainly indoor and in a stationary place, the reconfigurable intelligent surface (RIS) would be an attractive technology to achieve ultra-

	high data rate. RIS could be useful for deploying multiple transmission/reception point (TRP) operation with lower cost.
TC9. Flexible/full duplex scheduler	Flexible/full duplex scheduler on TDD band would be beneficial for extreme low latency operation. By using a flexible/full duplex scheduler, high priority packets could be transmitted anytime even when the resource is occupied by a low priority packet on a different link.

3.5.3.8 KPI Aspects & Requirements

This use case requires combination of high data rate and low latency. The network traffic model analysis is quite similar as described in Section 3.5.2.8. We consider this use case is similar to Virtual Reality (VR) as identified in [3]. However, high quality video is expected to improve the user experience, such as by providing high-resolutions with wide-angle view video. The transmitted video to the content processing server shall have the highest possible quality. The video quality at the end user could depend on many factors, such as the subscriptions-type, the device type, the link quality to the end-user. In [3], It has been identified that for the uplink video streaming, the default packet rate is 60 frame per seconds (fps), and the average data rate is 10 Mbps. For the motion/control of the user, the packet rate is 250 fps with the average data rate of 0.2 Mbps. For the audio/data, the average data rate is 1.12 Mbps. Lastly, for the uplink latency, the Packet Delay Budget (PDB) is 30 ms. Another way of considering the required data rate is from the required bit rate to deliver certain video coding. ACV and HEVC are the prominent video codec. ACV may require up to 150 Mbps to deliver 8k high quality video streaming. Even higher quality may be provided such as to provide 24k video and 360 degree – view which may require a few Gbps as described in the previous use case in section 3.5.2.9. Such high quality video may be required to deliver the video content to the end user (e.g., premium customer and the required link quality to the end user is supported). The video quality as the feedback may not require such high quality. It can be in the order of 50 Mbps to deliver 4k video quality.

We consider the following requirements in order to fulfil the service requirement of this use case:

Data rate

- UL 24K quality performance video streaming: 6.37 Gbps per camera
- DL 4k quality feedback of live video content: 50 Mbps

Latency (from UL streaming to DL feedback)

- Audio latency (Mouth-to ear latency): < 4 ms
- Video latency: < [20] ms

Reliability

- It can be up to 99.999% [16]

Synchronization

- Each of the multiple cameras and microphones need to be synchronized, similar requirements as described in section 3.5.2.9.

3.5.4 Augmented Reality (AR) Navigation

3.5.4.1 Descriptions

This use case considers augmented reality (AR) navigation powered by Artificial Intelligence/Machine Learning (AI/ML) powered digital assistance and operated typically in an urban city scenario. The AR device via the glasses provides the augmented reality image containing the information that could be useful to the user. The AR device may also be equipped with sensors, microphone, camera, speaker, and communication module. In principle, the AR device is a tool to gather the input, transfer the input to a server (processing node), receiving the post-process data (information) from the server, and provide the information to the user (via AR glasses, speaker). An AI/ML server is used to assist the user by providing the user's desired information based on various input to the server. In practice, this operation is inspired by the usage of an AI/ML tool where the user asks a question, and the answer is later provided by the AI/ML tool itself. In our case, the user may have interactive communication so that she/he provides the enquiry and receives the intended information, such as the best location and best route to the destination. In terms of usage, it can be illustrated in the following examples:

- When the user walks around a pedestrian street full of stores/restaurants, the user may ask via AR glasses concierge to find any interesting location based on user's need, such as the availability of nearby good restaurant. The AR will immediately provide the navigation information, such as the way and direction to go to the destination. At the same time, reservation can also be performed by concierge.
- In another example, the user walks on the pedestrian street. The user may retrieve information around the pedestrian street in his/her AR device. The information could be the information related to the shops or restaurants that is matched with the user preferences. It could also be generic information, such as the interesting item(s) or promotion(s) in a specific shop or restaurant. Here, the information retrieved by the user is controlled by the movement of the user itself. The AR system at the user is expected to support 6 Degree of Freedom (DoF) operation so that the movement of AR device (e.g., attached in the user's head), controllers and body movement in the space are all tracked.
- In another example, the user meets a person and wants to know a bit more information (e.g., names, occupation, hobby, etc). The AR device collects the information via its camera and/or microphone of the surrounding environment, such as a public space. Eventually the user may receive the intended information in the AR device (e.g., via glass and/or speaker).

This use case is illustrated in Figure 15. The users are the pedestrian users walking in a city street. In challenging scenario, it could also be the users traveling in a vehicle (e.g., bus or car). There can be multiple users equipped with AR devices on a pedestrian street. In addition to AR device, the user has a smartphone which could act as edge server and a local AP connected to the AR device and user's controller / sensors node(s). Furthermore, each shop/restaurant has a set information describing the shop/restaurant itself. The information can be the items inside the shop/restaurant, promotion information, etc. This information can be stored in a website or any kind of information database that can be accessed from the internet. For example, the application, such as in the cloud, can obtain such information. A form of subnetwork is established by having an AP that can reside in a smart phone and

the AP is connected to the user's devices, such as AR device, sensor(s) and controller(s). Furthermore, the AP maintains connection to the application cloud server via 6G Macro network.

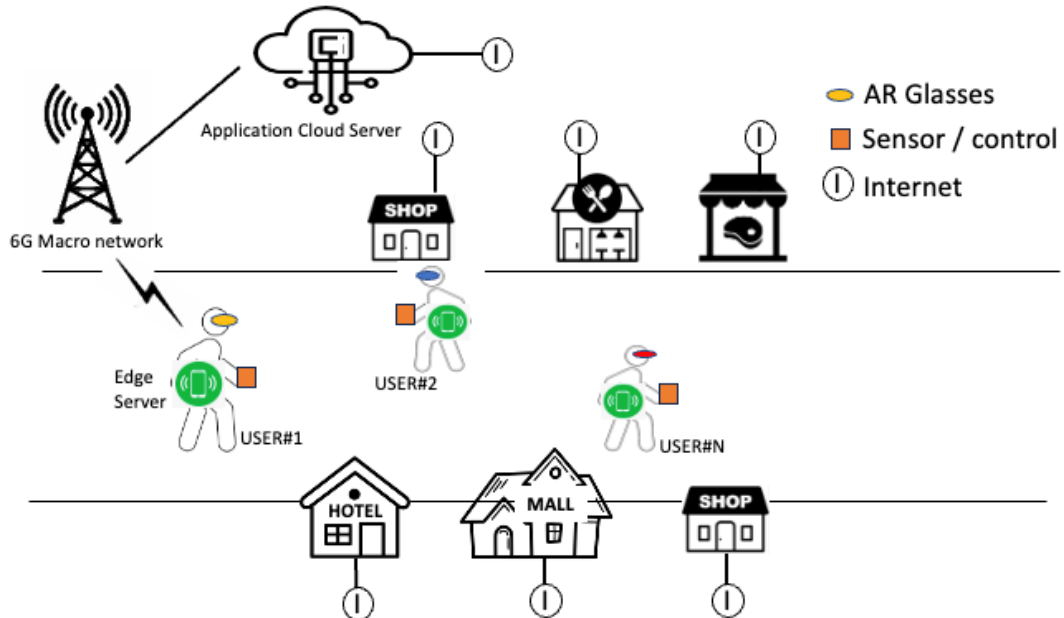

Figure 15: Illustration of AR Navigation

3.5.4.2 Pre-condition(s)

The application cloud server or in this case the AI/ML server is connected to 6G macro network so that it can be reached by the user smart phone. The user smart phone also supports an AP functionality so that it can connect to the devices belong to the users (e.g., AR device, sensor(s), controller(s)). The shop / restaurant has provided its information (e.g., products, items, sale/promotion) that can be accessible via internet / application.

3.5.4.3 Operation Flow

The operation flow of this use case can be described as follows:

1. Initialization / Information collection:
 - a. The user triggers the operation by collecting the input within a certain duration of time, such as voice (e.g., question), image(s), user's body, AR headset direction). The input collection can be aperiodic, triggered by the user explicitly, e.g., press a button, or implicitly (e.g., body movements). For example, the input could be the user's preference, the user mentioned and captured by the microphone and/or the user stares in certain direction and this is captured by the camera.
2. Processing of the information:

- a. The collected information is transmitted to the AP via a local connection and post-processed in the edge cloud server residing in the AP. The edge-server transmits the post-processed information to the cloud application server.
 - b. The cloud application server further post processes the user's input and tries to link and match it with the data from e.g., the shop/restaurant.
3. Providing the output to the user:
- a. The cloud application server transmits the output, basically the information that is expected to be matched with the user's request. The information is transmitted to the user's AP and further transmitted to the edge-server.
 - b. The edge-server post-processes the input, particularly to provide the representative information to the AR glasses display and/or the speaker residing at the AR glass.

3.5.4.4 Deployment Scenarios

The user(s) are expected to be in a dense urban scenario, for example, in a pedestrian street in a city. Each user has its own personal network (i.e., a subnetwork) containing a HC element (e.g., smart-phone, UE) that is locally connected to AR glasses, speaker/microphone, sensor(s), controller attached to the user. The size of the subnetwork is expected to be around 1m. The HC acts as gateway connected to the 6G parent network (e.g., 6G base-station). The HC is expected to be mostly located in a user's pocket. Hence, we can consider there is no line of sight (LOS) link for the connectivity from/to the HC.

The frequency band for operation within a subnetwork can be FR1. We can consider the KPI requirements of this use-case, such as the bandwidth / data rate, can be supported when the use-case is operated in FR1. On the other hand, the frequency operation for the HC to 6G parent network can be FR1, FR2, or any other frequencies. We should consider the HC can be connected to 6G parent network depending on the operating frequency of the 6G base-station. The antennas at the LC and SNEs are expected to be simple antennas (e.g., low number of antenna elements) considering the size-constraints and low-complexity considerations. However, the antenna at the HC can be a sophisticated one. The HC needs to support both connectivity to the 6G base-station and the local devices within the subnetwork.

The user is expected to operate in a public area where there can be any other users. The other user(s) can also run / operate a similar use-case. We can expect the users can interfere to each other in certain conditions/situations (e.g., high number of users, etc).

3.5.4.5 Subnetwork Architecture

An architecture diagram for the AR navigation use case is shown in Figure 16. The HC can be connected to a 6G BS, that can manage radio resources among other subnetworks. A subnetwork in this figure represents the personal area network of a user. HC can be the mobile device of the user and locally connected to LC and SNEs. LC can be the AR glasses of the user and SNEs can be the sensors attached to the user to track the user 6 DoF movements. The HC is also connected to the 6G BS. The 6G BS is connected to the CN as well as to a CompN, that can take care of computational tasks related to the resource management of the subnetworks in the coverage area of the parent network. The CompN can also carry application specific computation, such as for the information computation, collecting the real

time data from other users, shops, restaurant. The computation can be assisted by AI/ML machine. CompN can receive the enquiry from the user and provide the accurate response to the user in a timely manner.

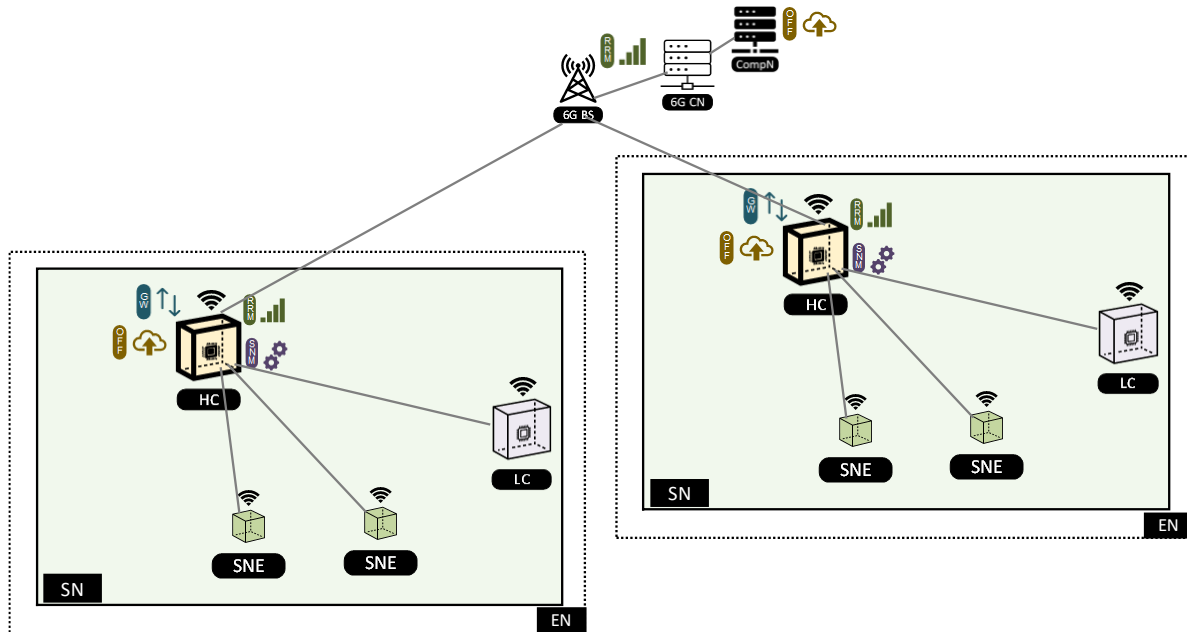

Figure 16: Subnetwork Architecture of the AR Navigation Use Case

The main functional requirements to support the subnetwork architecture of the AR navigation use case are listed in Table 13

Table 13: Functional Requirements of the AR Navigation Use Case

ID	Functional Requirement
C-4-FR-1	In the initialisation phase, the system shall enable the devices (SNEs, LC, HC) to register, transfer capability to at least one of the HC.
C-4-FR-2	The system shall enable interference management function among subnetworks.
C-4-FR-3	The system shall enable interactive and real time operation within certain limited time budget.

3.5.4.6 Post-condition(s)

The user receives the intended information in the AR device based on the input that the user has provided to the system. The input can be in a form of voice (e.g., questions) and image (screen capture). The output is mostly displayed to the glass of AR device. The amount of information can also be selectively shown based on the priority level and/or user’s gesture or body movements.

3.5.4.7 Challenges to the 6G system

In this use case, it is expected that the user receives accurate information with relatively low latency based on the user's input. The delay in receiving the requested information reduces the user experience. Furthermore, it is expected that multiple users use the system simultaneously in the same place / area. Hence, we foresee the following one or the combinations of challenges that must be fulfilled in 6G system:

- The ability to collect input from multiple sources (i.e., various sensors, speakers, camera, etc) simultaneously at the user side, where the timing of collecting information should be aligned when received at the local AI/ML server (edge-server) (e.g., within a limited time window). The usage of time stamp can also facilitate this operation.
- The ability to collect the information, process the information, and provide the output in timely manner, i.e., with a low latency. The information processing can be both at the edge-server and cloud application server.
- The ability of handling interference / jamming by the system as the system is operated in uncontrolled environment (i.e., public space) where there can be other users with the same system or other systems that may be operated in the same spectrum.
- Operating the system in an efficient manner so that the user devices are supported in a relatively small form factor and with reasonable battery life.

In order to address the above challenges, we consider the following technical components (TCs) are highly relevant for this use case. Other TCs can still be relevant and are shown in section 3.6.

Table 14: Selected Key TCs for Augmented Reality (AR) Navigation

Technology component (TC)	Explanation
TC09. Flexible / full duplex scheduler	To support low power transmission from sensors or other devices to the AP. The AP is collocated at the device / wireless terminal carried by the user.
TC10. Predictive scheduler	The user may receive periodic and/or scheduled information. Hence, a predictive scheduler could be facilitated to optimize resource allocation and ensure information with low latency requirements can be provided in time.
TC11. Latency-aware access in the unlicensed spectrum	The system is operated as a personal subnetwork to be used in a public space in which it can be deployed in unlicensed spectrum. Considering latency is an important aspect, a latency-aware access for a system in the unlicensed spectrum could be beneficial.
TC14. Jamming detection and mitigation	The system is expected to be operated in an uncontrolled environment (e.g., public space). Hence, the presence of jamming (e.g., due to the operation of other system or explicit jammer(s)) should be able to be detected and mitigated to ensure the operation of the use case.
TC15. Hybrid management of traffic, spectrum and computational resources	We expect there is a split operation / processing of AI/ML in the application server in the cloud and

	edge server. Distributed / hybrid resource management could facilitate the split operation of AI/ML function so that efficient radio resources and computation resources can be achieved.
--	---

3.5.4.8 KPI Aspects

This use case has certain subnetwork traffic characteristics covering the uplink and downlink transmission from the devices to the AP and vice-versa, respectively. The uplink transmission is mostly the input from the user collected from the microphone, camera, and sensors. The downlink transmission is the output to the user such that the information in response to the user’s enquire(s). We have identified the following key traffic characteristics:

1. Uplink video/image transmission
This is uplink transmission from the user. It could be a snapshot of video / image. The data rate expected should be medium as it does not require super high-quality video / image transmission. However, the periodicity can be frequent, and it may depend on the body movement of the user.
2. Voice / gesture / sensor transmission
This could be an event triggered transmission. On the other hand, the sensor’s outputs in obtaining the body movement should be rapidly transmitted.
3. Downlink video/audio/text streaming
This is the downlink transmission to the user, typically the information to be displayed in the glasses of AR device. The quality of the image/video may not be the most important aspect. The important aspect is the latency of the information so that the information can be provided at the right time.

Based on the above key traffic characteristics, we consider the KPI is quite similar as the KPI identified in Section 3.5.2.8. However, the video transmission quality can be significantly lower as the ultimate goal of this use case is to provide the relevant information to the user. The latency from providing the information (e.g., uplink video transmission), processing information (e.g., AI/ML computation based on multiple inputs), and post-processing information (e.g., display to the user) are the main requirements of this use case. The latency requirements could also be relatively more relaxed (e.g., tens milliseconds). The main function is to provide the information to the user which can be relatively latency-tolerant in comparison to the video rendering in indoor gaming scenario. However, in case the user is in a vehicle then the latency requirement is scale-up depending on the vehicle’s velocity. For synchronization, such as the synchronization from multiple devices (e.g., camera, microphone, sensors) are similar to the requirements as described in Section 3.5.2.8.

3.6 6G CHALLENGES AND 6G-SHINE TECHNOLOGY COMPONENTS RELATED TO CONSUMER SUBNETWORK

The use cases of consumer subnetwork as described above show stringent requirements in order to satisfy the user experience. In most of the cases, high data rates, low latency and high reliability

requirements are required, particularly to provide immersive experience using VR and AR glasses. In order to fulfil these 6G challenges, the list of relevant 6G-SHINE technology components is listed in Table 15.

Note: It does not necessarily mean to evaluate all these TCs for a given use case in the other technical WPs. The TCs will be evaluated for specific use cases, and eventually it may be elaborated on how these TCs can also be used in the other use cases.

Table 15: Technical Components (TCs) Addressing the Consumer subnetwork Use Case Challenges

Technology component (TC)	Use cases	Explanation
TC1. In-X data traffic models	All consumer use cases	General aid for developing a concept
TC2. Channel models for in-X scenarios	All consumer use cases	General aid for developing a concept
TC3. Sub-THz system models	- Indoor Interactive Gaming - Immersive Education - Virtual Content Production	Sub-THz transmissions are a promising technology to provide ample capacity for multiple users closely localized and enable short frame durations to support ultra-low latency and high reliability in suitable propagation environments. It can also be designed to offload the traffic from lower frequency bands.
TC4. Ultra-short transmissions with extreme reliability	All consumer use cases	Small latency enables more options for offloading within the subnetwork. However, consumer use cases may not require extreme reliability
TC5. Analog/hybrid beamforming/beamfocusing	- Immersive Education - Indoor Interactive Gaming - Virtual Content Production	Enable optimized communication with individual devices or groups of devices within the coverage area of a particular subnetwork
TC6. Jamming-aware native PHY design	AR Navigation	Navigation in an open space prone to possible jamming.
TC7. RIS enhancements	- Immersive Education - Indoor Interactive Gaming - Virtual Content Production	Enable steering of beams towards individual users within a room
TC8. Intra-subnetwork macro-diversity	Immersive Education	e.g., to achieve reliability for low latency
TC9. Flexible/full duplex scheduler	All consumer use cases	Depending on the selected offloading scheme for UL and DL related processing, there may be both significant uplink and downlink traffic, which is the scenario benefitting most from flexible/full duplex scheduling options
TC10. Predictive scheduler	All consumer use cases	Prediction helps optimize compute vs. communication trade-off

TC11. Latency-aware access in the unlicensed spectrum	All consumer use cases	Optimized latency in unlicensed spectrum enables more options for offloading within the subnetwork
TC12. Centralized radio resource management	All consumer use cases	Optimized resource allocation depending on the deployment scenarios.
TC13. Distributed/hybrid radio resource management.	All consumer use cases	e.g., distributed within the subnetwork
TC14. Jamming detection and mitigation	AR Navigation	Navigation in an open space prone to possible jamming.
TC15. Hybrid management of traffic, spectrum and computational resources	All consumer use cases	There is a trade-off between communication and compute when deciding about offloading strategies for the provisioning of multimedia content, e.g., rendering. To find the optimum setting and to maintain it despite variations in connectivity and compute demand requires an integrated approach to scheduling and resource management.
TC16. Coordination of operations among subnetworks in the same entity	All consumer use cases	If multiple subnetworks (e.g., within the classroom) serve the users, potentially via multiple local or edge servers, and considering that the subnetwork may be built from a hierarchy of personal subnetworks that aggregate each user's set of devices, this will be very relevant

4 INDUSTRIAL SUBNETWORKS CATEGORY

The widespread adoption of wireless technologies for industrial communication has been historically limited by the known wireless demerits, such as sensitivity to interference and to harsh radio propagation conditions, which can severely affect expected latency and reliability, as well as capacity. 5G has introduced the concept of URLLC, targeting 0.5-1 ms latencies and five-to-six nines reliability, paving the way for adoption of wireless for industrial services. Still, the targeted 5G requirements might not be sufficient for the support of very critical services. Given the challenges in supporting wirelessly the most demanding industrial use cases, part of the research focus in industrial communication has moved towards the support of deterministic, predictable and time sensitive traffic, including bridging of multiple network domains, while not necessarily aiming at sub-ms latencies and wired-like reliabilities. For example the SNS PREDICT-6G project aims at provisioning, monitoring, fulfilling end-to-end deterministic services across diverse networks [21], while the DETERMINISTIC 6G project will design a new architecture for 6G systems to predictable performance and integrating it end-to-end with TSN and DetNet [22]. Still, enhanced URLLC is at the core of academic research and considered for future 3GPP releases. It is one assumption of 6G-SHINE that, an intelligent technology design tailored to the specific characteristics of in-X subnetworks, can support requirements beyond 5G. For industrial subnetworks, 6G-SHINE will complement the work carried out by other SNS projects research technology enablers for enhancing latency and reliability of wireless communications, leveraging specific in-X industrial deployment characteristics. We present in this Section the current status quo, and an overview of use cases for short-range industrial communications, where in-X subnetworks can be a fundamental enabler. In the presentation of use cases, we use a bottom-up approach, starting with use cases where subnetworks are installed in single entities like robots and production modules, and then introducing subnetworks formed by robot swarms, and factory asset management.

4.1 STATUS QUO ON INDUSTRIAL NETWORKS

Industry 4.0 envisions a transformative progression of industrial manufacturing systems, blending cyber-physical systems, Industrial Internet of Things (IIoT), and cloud computing technologies. This evolutionary step necessitates a seamless interconnection of individuals, machines, and computational resources within manufacturing workflows. Fundamental to this new paradigm is the ability to gather and utilize data to reconcile the physical and digital worlds, thus enabling the development of new revenue channels and cost efficiencies. The challenge here lies in addressing diverse connectivity requirements pertaining to reliability, low latency, and capacity.

Currently, industrial networks feature an array of wired-oriented solutions such as Ethernet-based networks and field buses. In tandem, the IEEE 802.1 TSN task group is crafting standards to enhance the Ethernet networking model to ensure deterministic streaming services. The IEC/IEEE 60802 is also developing the TSN profile for industrial automation. In contrast, wireless systems have yet to become popular due to concerns over the reliability and performance of industrial-grade deterministic communication [23], and some parts of the ecosystem still remain to become mature, too. As a result, wireless networks currently have a limited footprint, extending only into areas of factory process

automation and other noncritical applications. The wireless communication sector gained a clearer understanding of the integration scenarios and reliable communication requirements of industrial use cases only recently. The 3rd Generation Partnership Project (3GPP) and 5G-ACIA, along with the close collaboration between wireless communication and industrial sectors, have led to the development of industry-specific, time-sensitive, ultra-reliable, and massive-connectivity features in 5G networks [2], [26], [37], potentially paving the way towards the future 6G.

4.2 SWARM PRODUCTION AS A TREND AND THE ROLE OF 6G SUBNETWORKS

Achieving comprehensive connectivity throughout the entire value chain necessitates a pragmatic integration of wireless solutions with diverse manufacturing use cases. Wireless technologies can help eliminate cables, thereby speeding up the reconfiguration of production facilities and reducing the cost of deployment. Moreover, they can enable new industrial use cases that require full mobility support [23]. The imperative for enhanced wireless systems stems from two major trends.

1. Dynamic network customization:

There is a need for swiftly reconfigurable and modular production lines, or 'swarm' production, to scale capacity, speed, and control in response to evolving manufacturing demands [23]-[24]. Current production lines are typically statically configured due to the expense and complexity of cable management. Wireless connectivity can deliver the required flexibility, but this complicates radio resource allocation and network management.

2. Mobility and collaboration:

Support for mobile objects such as AGVs, robots, and control panels and their collaboration in flexible/modular manufacturing is key to automating repetitive, labor-intensive, and costly tasks. Such mobility and collaboration-oriented use cases require robust wireless connectivity to ensure fail-safe operation.

Understanding current and envisioned use cases specific to certain scenarios and their communication requirements can lead to the optimization of integrated wireless solutions. By supporting full mobility and replacing cables, wireless automation holds transformative potential for industrial production systems.

The manufacturing sector is rapidly evolving towards creating highly adaptable infrastructure, primed to cater to the increasing demand for customized products. This adaptability can be best achieved by embracing the concept of swarm production [24]. Characterized by decentralized, non-linear production workflows, swarm production relies on Autonomous Mobile Robots (AMRs) to transport products between diverse manufacturing stations dispersed throughout the factory floor. Implementing such an adaptable, intelligent production system necessitates the amalgamation of various technology components, including cloud-computing, 6G communications equipped with URLLC capabilities, robotics, autonomous systems, and highly accurate localization systems.

However, transitioning from traditional production models to swarm production is a complex process. It is useful here to refer to the evolutionary roadmap for the production process suggested in [24], where the transition pathway from traditional manufacturing systems to swarm production is segmented into four progressive stages, predominantly focusing on (1) removing cables, (2) usage of cloud-based soft

Programmable Logic Controllers (PLCs), (3) cloud robotics, and (4) transitioning product carriers into small mobile robots (swarm production).

6G subnetworks can form the backbone of this technological integration [28]. Swarm production inherently requires high levels of reliability, low-latency communication, real-time adaptability, and complex control strategies. The expected features of 6G subnetworks align perfectly with these needs, making them an integral, logical element for facilitating the evolutionary trend towards swarm production.

4.3 BENEFITS AND CHALLENGES OF INDUSTRIAL SUBNETWORKS

Subnetworks are projected to bring significant advancements, including even higher data rates, lower latency, and increased network reliability and efficiency, among others. This could have notable impacts on the manufacturing industry comprising several benefits.

1. Enhanced connectivity:

6G subnetworks could potentially offer uninterrupted local and short-range connectivity, capable of ensuring extraordinarily high reliability alongside low latency. This advancement is critical for meeting communication requirements previously unattainable through 5G standards, such as high throughput URLLC and loop cycles of 100 microseconds. This paves the way for an array of novel use cases demanding complex and stringent network requirements, thus offering possibilities of novel applications and services.

2. Distributed computational architecture:

6G subnetworks could facilitate a new architectural paradigm that strikes a balance between localized processing and cloud computing. This could involve dividing the computational load between subnetworks and edge/cloud servers, optimizing the distribution based on the criticality and latency requirements of different tasks. Critical functionalities demanding ultra-low latency and high reliability, such as real-time process control, could be handled within the subnetwork itself, thereby minimizing delay and potential disruptions. On the other hand, tasks that are less time-sensitive, such as advanced analytics, machine learning model training, or supply chain optimization, could be offloaded to the cloud. This distributed computational model aligns with the vision of 6G as an enabler of a more flexible, responsive, and efficient manufacturing sector, while acknowledging the diverse requirements of different tasks and applications.

3. Replacement of traditional cabled connections:

This transition unlocks a preliminary level of flexibility, facilitating more straightforward reconfigurations of the production facilities compared to their wired counterparts. Furthermore, removing cables can enhance the flexibility of motion of robot parts, and maintenance, as it is easier to replace wireless components than wired ones.

Despite the promising benefits, there are also challenges with respect to the introduction of subnetworks.

1. Network Management:

The potential complexity of 6G subnetworks could make network management and radio resource allocation more challenging. In this context, AI can play an important role for enabling sophisticated predictive maintenance strategies and optimization methods.

2. Security:

With greater connectivity and more sophisticated networks, security threats could be more diverse and challenging to manage. Ensuring the security of data and network operations in a swarm production setting would be crucial.

3. High-precision requirements:

Swarm production requires high-precision operations, particularly when it comes to real-time control and coordination of machines, where the level of reliability required is in the orders of magnitude higher than in a typical public network 6G subnetworks are expected to support such real time operations, and coordination of tasks.

4.4 KVIs OF INDUSTRIAL SUBNETWORKS

The common KVIs applicable to all use-cases are elaborated in Section 1.3.3. In this section, the specific KVIs of industrial subnetworks are described. In congruence with the aims of the 6G-SHINE project, our primary objective within the realm of factory automation is to design technologies that address the social, environment and economic impact of 6G subnetworks, as presented in section 1.3.3., placing a strong emphasis on sustainability. The integration of flexible, low-power, and short-range wireless subnetworks within factory automation ecosystems fuels the evolutionary trajectory of manufacturing networks. Such progressive transition from wired to wireless connections within factories yields multiple benefits. It substantially mitigates operational costs and the physical heft of manufacturing machinery, leading to environment sustainability. Moreover, it bolsters production efficiency, facilitating the production of faster, more affordable, and higher-quality products for society. This transition aligns with the broader global efforts towards achieving a more sustainable future, while also driving significant economic sustainability.

A concise summary of KVIs of industrial subnetworks is presented in Table 16.

Table 16: Summary of KVI & Its enabler of Industrial Subnetwork Use Cases

KV	KVI	KVI Enabler
Social	Lower installation and maintenance cost due to higher flexibility introduced by wireless, possibly translating to lower cost of products	These KVIs are all enabled by the concept itself of in-X subnetworks, that can increase the pervasiveness of wireless in industrial settings, for example via support of low latency and high reliable communications.
Environment	Reduced carbon footprint (i.e., physical cable and items for the installation) Reduced wastage of devices, as only defective components have to be replaced and refurbished. Enhanced possibility of disassembling equipment and reuse materials.	

Economic	<p>Improve / optimize the industrial operation thanks to enhanced flexibility.</p> <p>Support circular economy thanks to the improved modularity introduced by wireless, allowing to refurbish and reutilize individual equipment parts.</p>	
----------	--	--

4.5 INDUSTRIAL SUBNETWORKS USE CASES

In the following, the relevant identified use cases for industrial subnetwork applications are described. As mentioned above, these use cases are complementing the current use case definition carried out by other SNS projects focused on industrial communications, such as PREDICT-6G [34] and DETERMINISTIC-6G [35].

4.5.1 Robot Control

4.5.1.1 Description

Inspired by [23], a relevant use case for industrial subnetworks is represented by the wireless control of robot operation. Examples can be the control of multi-axis robots for leveraging the degrees of freedom offered by potential movement directions the robot can accomplish; force control; control of moving and rotating parts in printing machines, packaging machines, or machine tools. As observed in [26], the usage of wireless for these applications can ease movements and rotation with respect to wired components, possibly enabling further degrees of freedom in the manufacturing operations. Robot control operations are usually relying on wired industrial technologies such as Profinet IRT or EtherCAT, and are supported by potentially very short communication cycles, down to 50 μ s and below, to ensure fast and accurate robot movements. This use case aims at translating, to a large extent, such wired communication technologies over wireless, while maintaining cycle times and expected quality of service. A pictorial representation of this use case is shown in Figure 17.

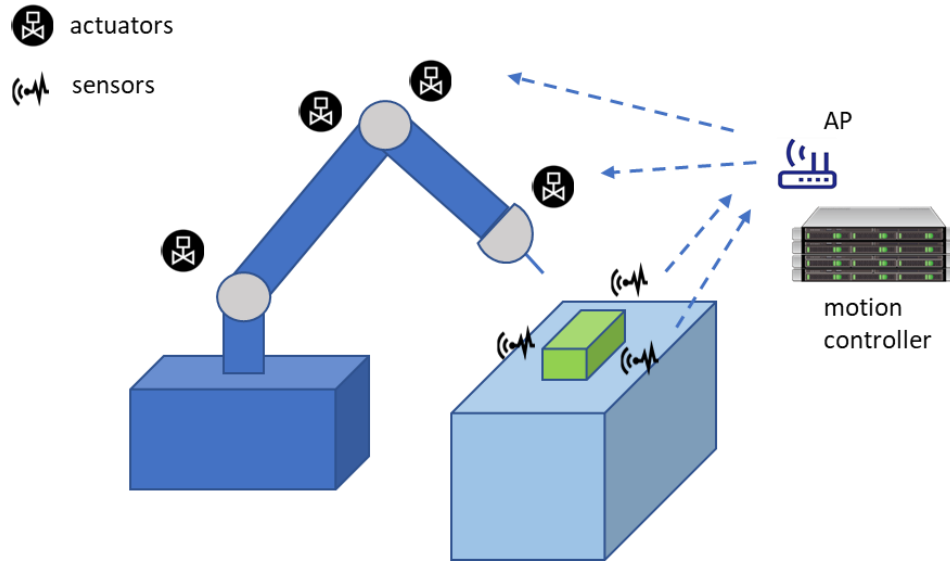

Figure 17: Illustration of the Robot Control Use Case

4.5.1.2 Pre-condition(s)

A robot control system consists of several sensors (e.g., position, rotation, and force sensors), a motion controller, and a number of actuators (e.g., linear actuators and servo drive). Most (or all) sensors and actuators can be connected to a subnetwork AP, which hosts motion controller capabilities. Alternatively, the motion controller is also a device connected to the subnetwork AP. When the machine is on, all devices connect to the subnetwork AP.

4.5.1.3 Operation Flow

The operation flow is based on a typical control cycle and can be exemplified as follows:

1. Sensors are measuring the actual values of the property of interest in the plant and transmit them to the subnetwork AP at periodic, deterministic cycles. Depending on the specific sensor, such cycles can be in the order of a few ms, down to around 100 μ s and below. Packets size can be in the range of 60-1300 bytes (see section 4.6).
2. In case the AP is equipped with motion controller capabilities, it will process the measurements sent by the sensors and generate a command (e.g., set points) for the actuators. In case the AP is not equipped with motion controller capabilities, it will forward the sensors' measurements to the motion controller device and receives the commands from it.
3. The subnetwork AP transmits the commands to the actuators at a predefined time according to the communication cycle. Actuators perform the command set by the controller.

Note that different cycle times might need to be efficiently multiplexed in a subnetwork, e.g., 10 - 100 ms down to <100 μ s. As highlighted in Section 4.6, besides the periodic traffic, also random/apperiodic traffic with exponentially distributed inter-arrival times can be present.

4.5.1.4 Deployment Scenarios

Subnetworks for robot control are installed in a factory, in a given production cell or mobile robot, whose volume can be in the order of 3-5 m³. Sensors and actuators can be installed in the robot parts (e.g., robot arm), as well as in the underneath plant where operations (e.g., assembly) are performed. The controller is installed in close proximity, i.e. within 3 m from the robot, or within the robot/ production cell itself. The AP can be co-located with the controller, and can be also connected with an enterprise (parent) 6G network, controlling the overall operations in the factory floor. Other network elements such as relays (when needed), can be placed in the subnetwork volume, for example at the edges of the plant. Relays can be wisely installed to ensure good line-of-sight conditions with the AP antennas, as well as possibly with the sensors/actuators that might be shadowed in their communication link with the controller. One or more RISs can also be eventually installed in proximity of the production cell, for example at the edge of the cell, perpendicular to the plant, or on a wall of the factory, possibly shared with other subnetworks.

Subnetworks can operate at different frequencies, including sub-THz. Number of antennas and panel sizes are therefore depending on the used operational frequency, as well on practical installation constraints. A significantly lower number of antennas is expected at the sensors with respect to relays and APs. FR3 range, spanning from 7 GHz to 24 GHz, can be considered a promising option given the amount of spectrum and higher robustness to blockage than sub-THz bands.

In case of sequential production line, production cells (and subnetworks) can be adjacent to each other. In a matrix production mode [25], where production cells are arranged in a grid layout, a minimum mutual distance among subnetworks of at least 2m is foreseen.

4.5.1.5 Subnetwork Architecture

Architecture diagram for the use case is shown in Figure 18. Sensors and actuators are SNEs, while the subnetwork AP can be a HC device. SNEs can communicate directly to the HC, or via LCs configured as relays. Though not shown in the figure for the sake of visual simplicity, RISs can eventually be used in place of relays, or combined with them. The HC can be connected to a 6G BS, that can manage radio resources among other subnetworks. The 6G BS is connected to the CN as well as to a CompN, that can take care of computational tasks related to the resource management of the subnetworks in the coverage area of the parent network.

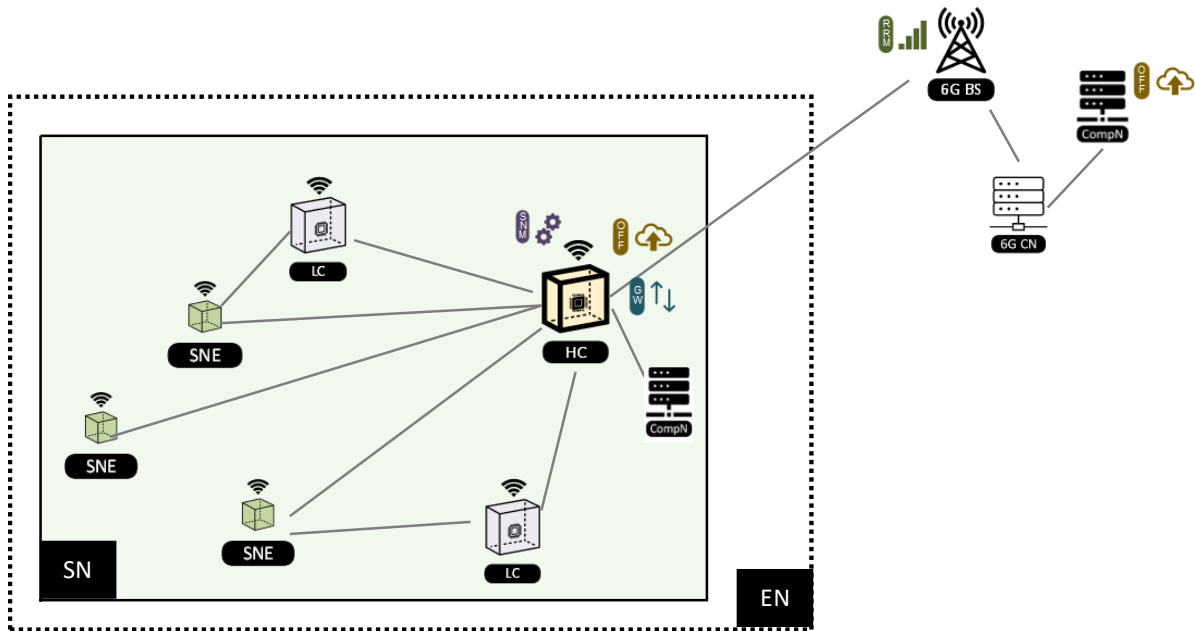

Figure 18: Subnetwork Architecture of the Robot Control Use Case

The main functional requirements to support the subnetwork architecture of the robot control use case are listed in Table 17.

Table 17: Functional Requirements of the Robot Control Use Case

ID	Functional Requirement
I-1-FR-1	The system shall enable the HC to discover associated SNEs, and eventually LCs, in the initialization phase.
I-1-FR-2	The system can enable LCs to act as relays of the signals transmitted from/to the SNEs towards the HC.
I-1-FR-3	The system shall be able to connect with a parent network when available, that can aid radio resource management and enforce robust authentication/authorization policies.

4.5.1.6 Post-condition(s)

By following the communication cycles without loss of messages, the robot can correctly perform its operational task including the movement/rotation of its parts.

4.5.1.7 KPI Aspects & Potential Requirements

Relevant challenges for supporting this use case are already presented in [2]. These can be summarized as follows. On one hand, the system must be able to support very short communication cycles, in the order of 100 μ s or below, with varied packet sizes in the range 60-1300 bytes, and a probability of having two consecutive errors $< 10^{-6}$. On the other, the system must be able to ensure a high level of synchronicity among its parts, e.g., with a jitter below 1 μ s, such that measurements reported by the

sensors can be time aligned. Additionally, the system must be able to support many sensors and actuators, e.g., in the order of 50.

Besides, there are other relevant challenges. Since not all communication loops may require $\sim 100 \mu\text{s}$ cycles, the system must be able to efficiently support different communication cycles, e.g., 10-100 ms, in the same air interface. Moreover, sensors and actuators can be mounted over robot parts in motion, with speeds up to 20 m/s. The system should then be able to ensure the expected communication quality with mobile devices (whose motion can, however, be predictable). Since a production line can include many robots performing their dedicated tasks, and each robot can have its dedicated subnetwork, subnetwork density can be very high, therefore generating potentially high levels of mutual interference. Also, it is worth observing that robot control tasks can happen over mobile robots, and therefore the mutual interference levels may vary depending on the mutual robot position.

4.5.2 Unit Test Cell

4.5.2.1 Description

This use case is also inspired by the analysis of data traffic characteristics in relevant industrial use cases based on wired setups [27]. A unit test cell is meant to perform quality assurance tasks of product parts in the manufacturing process, as well as of devices used in the manufacturing process. For example, it can be used for providing calibration and tolerance figures for actuators to be used in a factory, to make sure they comply with predefined requirements during execution.

4.5.2.2 Pre-condition(s)

A unit test cell, as depicted in Figure 19, can consist of a test rig where the device under test (DUT) is placed together with actuators and sensors meant for assuring its quality. The actuators can be activated by a control computer according to a specified control sequence delivered to them. The sensors continuously measure the performance of the device upon the actions performed by the actuators to emulate real world movements and forces, and report the measurements to the computer. A Human Machine Interface (HMI) device can connect to the computer for real-time monitoring, and also for setting different instruction set. Once the test sequence is finished, the results collected by the computer can be reported to a factory common database. We assume a wireless subnetwork consisting of an AP co-located with the control computer. The actuators acting on the DUT, and the sensors, are connected to the subnetwork AP, i.e., one connection per device. Another option consists of having a sensor aggregator connected wirelessly or via fieldbus with all sensors that aggregate all the measurements to be reported to the soft PLC.

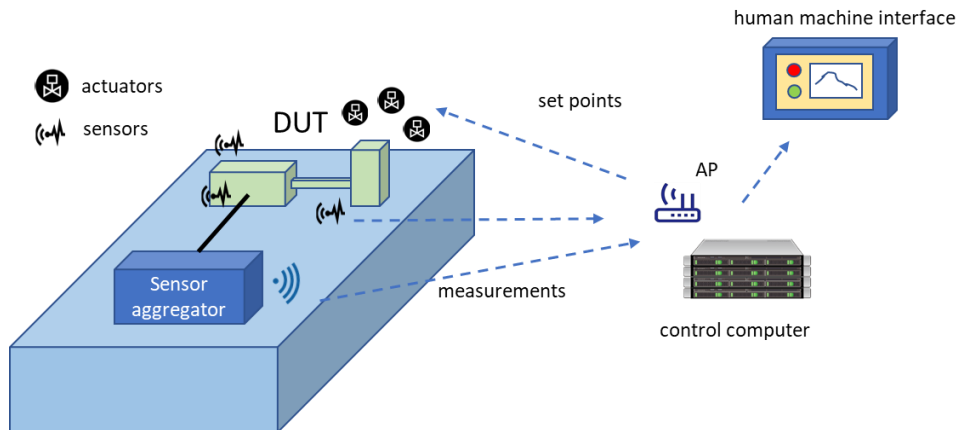

Figure 19: Illustration of the Unit Test Cell Use Case

4.5.2.3 Operation Flow

Once the DUT is placed on the test rig, the operation flow is the following:

1. The computer controller generates a sequence of operations to be performed by the DUT.
2. The subnetwork AP, co-located with the computer, forwards the sequence of operations to the actuators.
3. The actuators perform the operations in the list on the DUT and the sensors are measuring continuously the parameters of interest.
4. In case sensors are equipped with wireless capabilities, they will transmit their measurements to the subnetwork AP. Such measurements can be transmitted in a periodic or aperiodic fashion. In the presence of a sensor aggregator, these measurements are first collected and then transmitted by the sensor aggregator to the subnetwork AP.
5. The control computer stores the measurements, which are utilized to assess the quality of the DUT performance.
6. During the process, a HMI can connect to the control computer for real-time visualization of performance, as well as for pushing new tests.

4.5.2.4 Deployment Scenarios

Unit test cells can be installed in a workshop or in a factory floor. Expected size of a unit test cell is in the order of 3-5 m³. The AP and the associated control computer can be within a 3 m distance. Sensors and actuators are located on the test rig, possibly at a short mutual distance down to 0.25 m. The sensor aggregator, if present, is located in close proximity to the test rig. Whenever possible, AP antennas can be located in line-of-sight conditions with the test rig, while relays can eventually be installed at the edges of the rig. We can assume the unit test cell to be in the coverage area of a parent 6G network, e.g. an enterprise network. The HMI can connect to the parent network for real-time visualization of the test performance.

Considerations for the usage of RIS and operational spectra are the same as for the robot control use case.

4.5.2.5 Subnetwork Architecture

The architecture for this use case is shown in Figure 20. Actuators are SNEs, and receive commands from the HC. Communications can be direct, or via LCs acting as relays. Also RISs can be included in place of LCs. The sensor aggregator can be a LC that communicates –directly or via relay- to the HC. Similarly to the previous use case, the HC can be connected to the 6G parent network. The HMI can be a UE that connects to the 6G network, for monitoring performance of the unit inspection cell managed by the corresponding subnetwork.

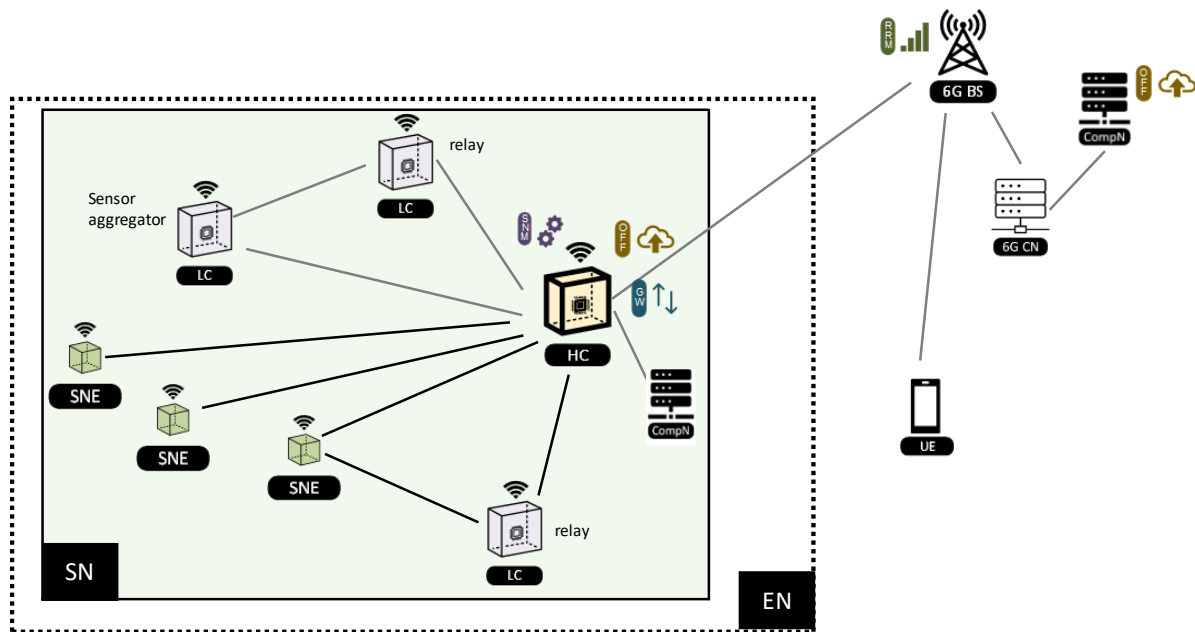

Figure 20: Subnetwork Architecture of the Unit Test Cell Use Case

The functional requirements to support the subnetwork architecture for the unit test cell use case are presented in Table 18.

Table 18: Functional Requirements of the Unit Test Cell Use Case

ID	Functional Requirement
I-3-FR-1	The system shall enable the HC to discover associated SNEs and LCs in the initialization phase.
I-3-FR-2	The system shall be able to instruct the LCs to connect with each other (sensor aggregator connect to the relay) if needed.
I-3-FR-3	The system shall be able to discover an external UE (for HMI), and connect to it.

I-3-FR-4	The system shall be able to connect with a parent network when available, that can aid radio resource management and enforce robust authentication/authorization policies.
----------	--

4.5.2.6 Post-condition(s)

At the end of the test sequence, the control computer has received relevant quality measurements (e.g., tolerance and accuracy figures from an actuator as the DUT). It can then forward these measurements to a factory common database. This may happen over a wireless system other than a 6G subnetwork.

4.5.2.7 KPI Aspects & Potential Requirements

The main challenge to the 6G system of the presented use case is the need to transmit sensor measurements to the control computer with low latency and low jitter. It is important indeed that the measurements from the multiple sensors are time aligned to calculate properly the performance figures at the controller. This might be particularly challenging in the case where the sensors are transmitting individually their measurements to the subnetwork AP, rather than relying on a sensor aggregator.

- The system must be able to support short communication interval below 10 ms for transmissions between the sensors and the subnetwork APs, with packet sizes in the order of 200 bytes, and the probability of having two consecutive errors $< 10^{-6}$. Transmissions from sensors can be periodic, or aperiodic.
- Up to 20 sensors are to be served.
- Short communication intervals must be kept also in case sensor information is aggregated, and therefore transmitted as a single message by the sensor aggregator. Since measurements should be timely aggregated for generating commands to the actuators, a high level of synchronicity with $< 10 \mu\text{s}$ errors is required.
- The system should also support more relaxed communication intervals, e.g., 20-100 ms, using same air interface.
- A HMI should be able to dynamically attach and detach to the subnetwork.
- The control computer should also be interfaced with an external database, for reporting periodically the measurements.

4.5.3 Visual Inspection Cell

4.5.3.1 Description

This use case is also inspired by our analysis of data traffic characteristics in relevant industrial scenarios [27]. A visual inspection cell performs quality assurance in the manufacturing process using video feeds. The video feeds are processed, and quality control is performed, by eventually outputting commands to actuators in case actions are to be taken for improving operation quality.

4.5.3.2 Pre-condition(s)

A visual inspection cell, as it is illustrated in Figure 21, can be installed in proximity to a conveyor belt that transports parts for assembly tasks over multiple production modules. It consists of a camera (or multiple cameras) pointed at a specific portion of the conveyor belt, an image processing unit (IPU), a soft PLC, and an actuator, which take care of performing quality control actions. Cameras may also have in-built laser sensors. The cell can also include a HMI device, for general monitoring purposes. The HMI can eventually attach and detach from the visual inspection cell during runtime operations, without the need of interrupting the operations. We assume the camera, IPU, actuator, and HMI device to be connected wirelessly to a subnetwork AP. In a possible implementation, the AP is co-located with an edge processing server performing the soft PLC control tasks. In another implementation, the edge processing server is another device connected to the subnetwork AP. Similarly, the IPU can eventually be co-located with the camera or connected to it via a wired connection. In this case, the camera and the IPU represent a single device from the subnetwork point of view.

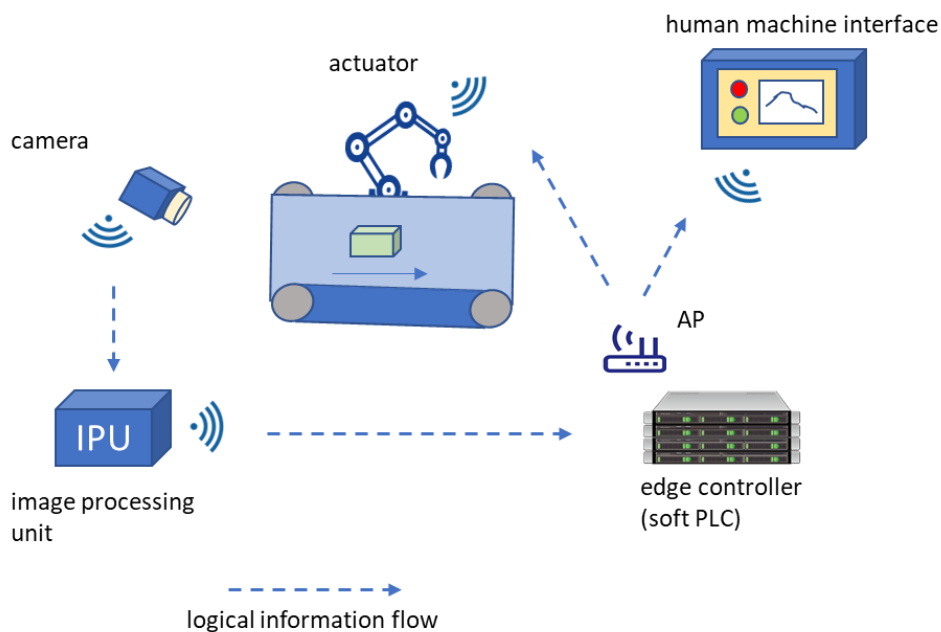

Figure 21: Illustration of the Visual Inspection Cell Use Case

4.5.3.3 Operation Flow

Let us consider first the case where all the devices (camera, IPU, edge controller, actuator, and HMI) are wirelessly connected to the subnetwork AP. The operational flow is then the following:

1. The camera streams video (or a laser-generated 3D profile) of the production items passing over the conveyor belts to the subnetwork AP.
2. The subnetwork AP transmits the video to the IPU device.
3. The IPU device performs quality control tasks by comparing the received video with a collection of images of correctly assembled products, for the sake of detecting possible discrepancies. In case discrepancies are found, the IPU issues a message meant for the edge controller and transmits it to the subnetwork AP.
4. The subnetwork AP receives the message for the IPU and forwards it to the edge controller.
5. The edge controller processes the message received and outputs a command for the robots in the assembly line by sending a command to the actuator controllers. For example, in case the

product is deemed to be faulty, it will instruct the robots in the production line to remove it from the conveyor belt or to re-direct it to a different production line. In case the product fulfils the quality specification, it can be forwarded to the next manufacturing cell.

6. During the process, the edge controller can transmit status updates on the actions taken to the subnetwork AP.
7. The subnetwork AP transmits the status updates to the HMI, in case this is connected to the network, for general monitoring purposes.

The above-described operation flow may be simplified in case some of the devices are co-located or wired-connected, e.g., camera with IPU, subnetwork AP with edge controller, as the corresponding wireless communication link can be removed from the process. Also, the operation flow presented above subsumes a star topology where all transmissions are directed to the subnetwork APs. One may explore the possibility of enabling direct communication among devices, configured by the AP itself. For example, the camera can stream the video feeds directly to the IPU rather than to the subnetwork AP.

4.5.3.4 Deployment Scenarios

Visual inspection cells can be installed on a linear or non-linear production line, at one or more production cell. A visual inspection cell can have a volume between 3-5 m². Camera(s) can be located on top of the production cell, oriented towards the plant, e.g. at 1-2 m height. The IPU can eventually be located on the plant itself. The HC and the edge controller can be located within a 3 m distance from the cell.

Regarding the usage of RIS, operational frequencies and HMI, same considerations as for the two previous use cases hold.

4.5.3.5 Subnetwork Architecture

Architecture diagram for the visual inspection cell use case is shown in Figure 22. Camera can be an LC and can communicate directly with the IPU in case they are not co-located. The IPU is also an LC and connected to the HC. Actuators are SNEs and receive commands from the HC, either directly or via LCs acting as relays. SNEs can also be used in place of relays. Similarly, to the previous use cases, the HC can also be connected to the parent network, that can take care of resource computation tasks. The HMI can be a UE connected to the parent network for the sake of monitoring visual inspection cell operations.

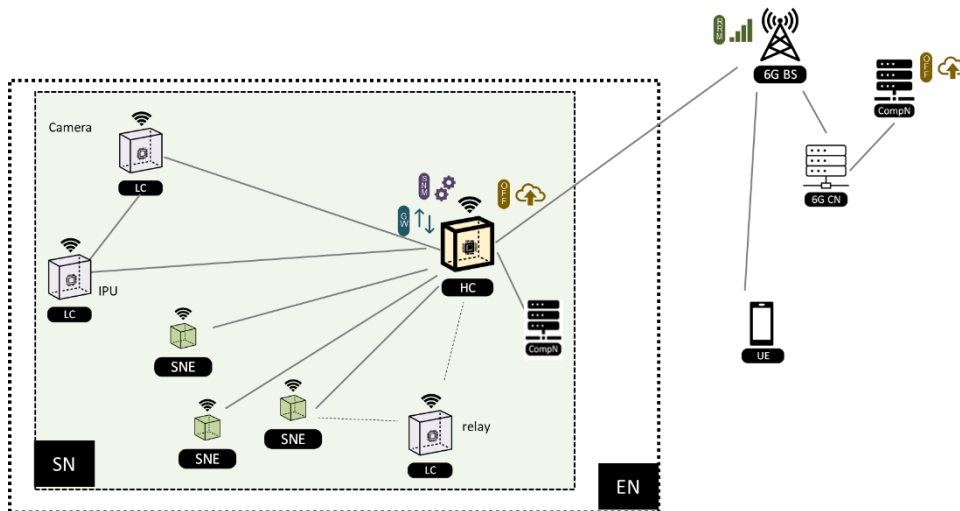

Figure 22: Subnetwork Architecture of the Visual Inspection Cell Use Case

Functional requirements to support the subnetwork architecture for the visual inspection cell use case are listed in Table 19.

Table 19: Functional Requirements of the Visual Inspection Cell Use Case

ID	Functional Requirement
I-2-FR-1	The system shall enable the HC to discover associated SNEs and LCs in the initialization phase.
I-2-FR-2	The system shall be able to dynamically assign roles to the SNEs and the LCs, e.g. to whom they should transmit to, or receive from.
I-2-FR-3	The system shall be able to discover an external UE (for HMI) and connect to it.
I-2-FR-4	The system shall be able to connect with a parent network when available, that can aid radio resource management and enforce robust authentication/authorization policies.

4.5.3.6 Post-condition(s)

As a result of the visual inspection cell operation, quality of production is ensured in a timely and efficient manner since eventual faulty parts are promptly removed from the production pipeline or corrected via further manufacturing process.

4.5.3.7 KPI Aspects & Potential Requirements

The successful execution of the visual inspection cell operation poses significant challenges to 6G subnetwork operations.

In case all devices are communicating via the subnetwork AP, this should be able to efficiently multiplex different traffic types. The video feeds transmitted by the camera(s) to the IPU require large data rates (e.g., ~50 Mbps per camera in the case of 4K videos). In case of laser cameras, traffic may have both

periodic components, with packet sizes ranging between 200 bytes and 2 kbytes, and components with exponentially distributed inter-arrival times, depending on the adopted protocols (see section 4.6). The expected data rate in this case (calculated upon the measurement results presented in section 4.6) is in the order of 5 Mbps. Conversely, the communication between IPU and soft PLC, as well as between soft PLC and actuator, involves small packets (e.g., in the order of 100 bytes) with potential sub-ms arrivals, and packet error rates $< 10^{-6}$, to ensure that potentially faulty products are removed from the production line.

The system should be able to dynamically add and remove the HMI devices without affecting the current runtime operations of the visual inspection cell, e.g., without adding any additional delay. Communication with the HMI device is best-effort traffic, in the order of 10 Mbps.

Table 20 summarizes the main requirements of the three presented use cases, referring to subnetworks installed in a single entity. It is fair to recall that such requirements are based on protocols that are natively designed for wired communications. In the future, control systems can potentially be designed jointly with the wireless protocols: this way, wireless communication performance requirements can be relaxed since the control system is able to compensate errors introduced by the imperfect wireless interface.

Table 20: Summary of the main requirements of the three use cases in the Industrial category

Use case	Purpose	Requirements
Robot control	Control of moving and rotating parts in printing machines, force control, packaging machines, or machine tool	<ul style="list-style-type: none"> - Packet size: 60-1300 bytes - Communication cycles down to $< 100 \mu\text{s}$ - Jitter $< 1 \mu\text{s}$ - Probability of two consecutive errors $< 10^{-6}$ - Up to 50 sensors/actuators - Device speed up to 20 m/s
Unit test cell	Quality assurance tasks of product parts in the manufacturing process	<ul style="list-style-type: none"> - Packet size: ~ 100 bytes - Communication cycles down to < 1 ms - Jitter $< 1 \mu\text{s}$ - Probability of two consecutive errors $< 10^{-6}$ - Up to 20 sensors
Visual inspection cell	Quality assurance in the manufacturing process by means of video feeds	<ul style="list-style-type: none"> - Packet size: ~ 100 bytes (communication soft PLC-IPU) - Packet interarrival time can be $< 100 \mu\text{s}$ - Low latency traffic to be multiplexed with high data rate traffic due to camera feeds <ul style="list-style-type: none"> o ~ 50 Mbps per video camera, o ~ 5 Mbps laser camera - Possibility of adding new devices (HMI) during execution without affecting performance

4.5.4 Subnetworks Swarms: Subnetwork Co-existence in Factory Hall

4.5.4.1 Description

In many manufacturing processes, particularly those in the electronics or automotive sector, tasks can be distributed among a swarm of smaller, specialized robots. Each robot is configured to perform a specific function or a series of functions. Working in concert, these robotic swarms can assemble intricate products with an expected level of efficiency that may surpass conventional assembly lines. Critical to this coordinated operation and the targeted increased efficiency is the concept of collaborative problem-solving. In this model, each robot not only performs its individual tasks but also shares information with the other robots in the swarm. This real-time data sharing ensures a seamless workflow and allows the swarm to tackle complex problems that would be challenging for a single robot or a human operator to address.

To meet the stringent communication requirements intrinsic to swarm operation, the role of 6G subnetworks becomes crucial. In this use case, the concept of subnetworks is to be applied at a higher level than the previous use cases hierarchically, as it refers to a swarm of connected robots.

In the context of a manufacturing scenario as illustrated in Figure 23, multiple co-existing subnetworks play a pivotal role. They maintain reliable and efficient communication and control among various AGV formations (robot swarms) and production lines.

These subnetworks need to manage potential challenges related to spectrum sharing, interference management, and resource allocation. These factors, if not properly managed, could lead to a degradation in the control system's performance. To tackle this, each sub-network might include a device capable of receiving command guidelines from a parent network, thus enabling smooth RRM among adjacent subnetworks.

Research is underway to develop strategies to achieve 100 μ s loop cycles with reliability levels ranging from 10^{-6} to 10^{-9} for control in-X traffic [37]. Additionally, it aims to ensure the support of Gbit/s link throughput with 5 - 10 ms average latency for best-effort traffic, as outlined by the 3GPP TS 22.261 use cases for cyber-physical systems [1].

Further challenges lie in devising control system strategies that align with the operation of the subnetwork. For example, the process may be further optimized when joint control and network design is pursued [31], in order to ensure the seamless integration of 6G communication technology with swarm robotics.

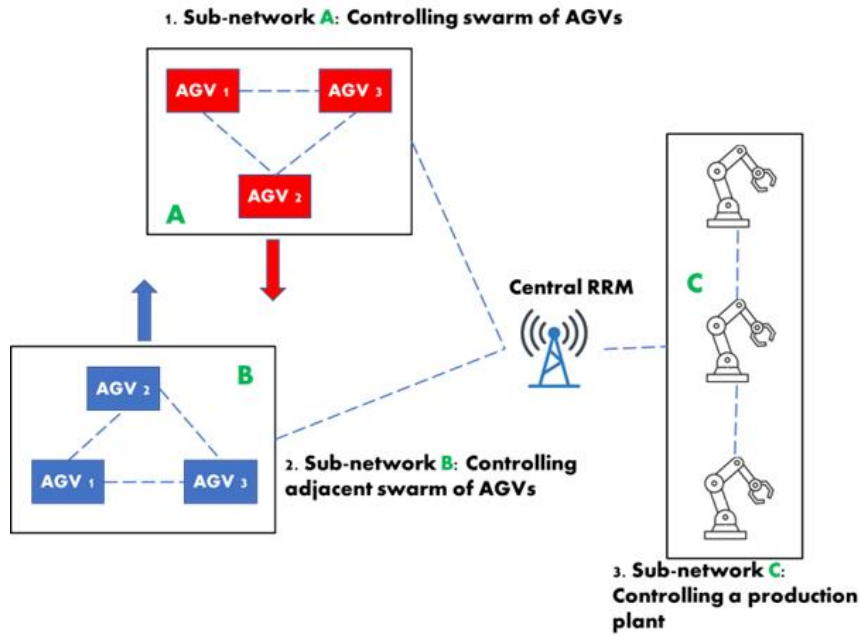

Figure 23: Illustration of the Subnetwork Co-existence in Factory Hall Use Case

4.5.4.2 Pre-condition(s)

The industrial environment/setup is comprised of a heterogeneous assortment of robotic systems, each engineered to execute distinctive manufacturing operations. Discrete control entities, such as Programmable Logic Controllers (PLCs), are implemented either entirely or partially within the confines of an edge infrastructure, which in this case is given by a nearby devices with high compute capacity empowered with edge capability, as illustrated in Figure 24. In this case, critical traffic, such as sensor and control information, are exchanged between the devices, instituting a localized, short-range subnetwork that leverages the edge computing capabilities inherent in a selected device within this subnetwork.

The 6G Network (e.g., enterprise base station or gNodeB) is responsible to handle radio resource management (RRM) when adjacent subnetworks must co-exist, either in a static or a mobility scenario.

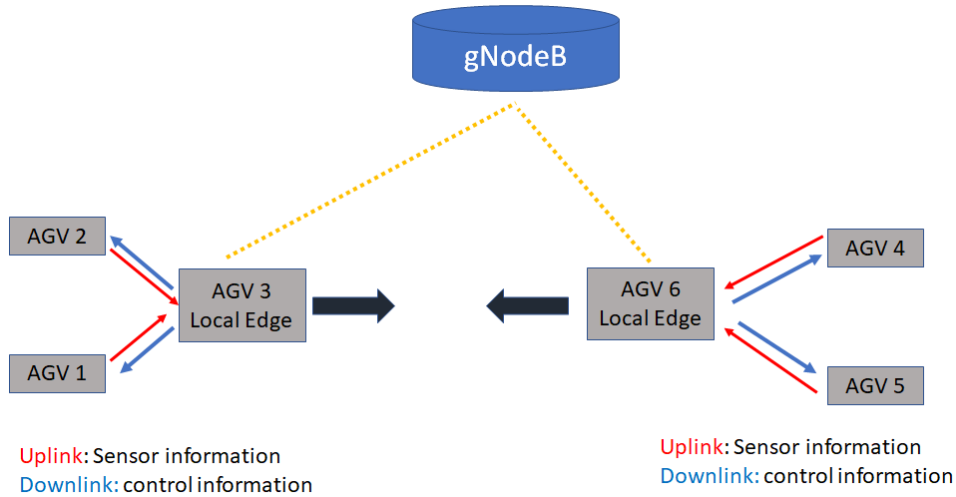

Figure 24: Example of a pre-condition for the co-existence of two adjacent sub-networks.

4.5.4.3 Operation Flow

Considering a set of robots, the flow of operations is described as follows:

1. Initially, each robot in the set identifies itself to device 3 (the edge-capable device) in the star topology subnetwork. These identifications could be through unique IDs or signatures that each robot carries.
2. The robots (devices 0, 1,... N) will constantly send sensor information like camera data, Lidar readings, temperature, etc., to device 3 using their assigned frequency bands. This data exchange could be carried out using advanced communication protocols to ensure efficient and reliable data transfer.
3. After receiving the sensor information, device 3, equipped with PLC capabilities, processes it internally to determine the required control functions. This may involve sophisticated algorithms that consider different robot functions and their states, environmental parameters, etc.
4. Device 3 then sends back the computed control information to each respective robot, thus closing the control loop. The data sent back can include motion control data, task assignments, error corrections, etc.
5. Upon receiving the control loop data, each robot applies the received control instructions to its actuators and executes the corresponding commands. The execution could involve various tasks such as moving, picking, aligning, etc.
6. The edge-capable device (device 3) must also actively manage potential interference within the subnetwork to ensure the smooth functioning of the closed-loop connection. This could involve advanced interference management techniques like adaptive beamforming, dynamic spectrum access, etc.
7. In scenarios where another set of robots (a different subnetwork) enters the wireless collision domain of the subnetwork, the management of inter subnetwork interference is handled by the corresponding 6G network gNodeB, to which the edge-capable device is attached. This could involve coordination strategies such as network slicing, flexible duplex, dynamic spectrum allocation, etc.

8. It would also be important to have a monitoring and updating mechanism in place. Device 3, along with the gNodeB, should continuously monitor the network performance, robot functioning, and other relevant parameters. Based on this, regular updates and adjustments can be carried out to ensure optimal performance and efficient resource utilization.
9. In a swarm-production environment, robots may exhibit emergent behaviour based on their interactions. Device 3, as the edge-capable node, should have protocols and algorithms to identify, analyse, and manage such behaviours to prevent any disruption or inefficiency.
10. Considering the critical role device 3 plays, it might be worthwhile to have a backup or redundancy mechanism in place. In the event of a failure or issue with device 3, a secondary device could take over the control and management functions to prevent disruption to the operations.

4.5.4.4 Deployment Scenarios

In general, we can distinguish between two cases: automated guided vehicles (AGVs) performing one or multiple intra-logistics tasks, and collaborative robots being responsible for non-logistics manufacturing tasks that demand for close collaboration between at least two such robots.

Intralogistics deals with in-time delivery of materials and assets through AGV fleets, the size of which ranges between five and multiple tens of AGVs in a factory hall. Material is usually stored either in warehouses or at so-called supermarkets. Supermarkets are designated areas within a factory, often exhibiting a size of about 10 m by 10 m, from which AGVs collect the assets and them to the production lines. At times of high material flow, multiple AGVs meet within the corridors and at the supermarkets, which demands for ad-hoc forming of AGV groups to efficiently coordinate the manoeuvring among those AGVs. We can assume up to five AGVs per group within such an area and also up to five groups within a factory with high demand of intra-logistics tasks.

Collaborative robots can be assumed to not be as mobile as AGVs but their interaction can be required in an on-demand manner, too, although often in a pre-planned setup rather than in unplanned situations of occasionally meeting AGVs having no collaborative tasks. Typical collaborative actions are sequences of production, inspection, pick and place operations, etc. at certain pre-defined areas in a factory. We can assume these areas to be in the order of 10 m by 10 m, as well.

4.5.4.5 Subnetwork Architecture

Figure 25 depicts the architecture for subnetworks in the Subnet Co-existence in Factory Hall use case. There are two entities, which can be groups of robots or AGVs, with three such collaborating sub-entities. The architecture represents a form of nested subnetworks, where each group of AGVs or robots is represented by a subnetwork on a higher hierarchical level and where each of the AGVs or robots implements another subnetwork on a lower hierarchical level. The lower subnetworks are essentially within the device and comprise local PLCs (HCs and LCs), sensors and actuators (SNEs). Because the group subnetworks can be in close vicinity, there needs to be an overarching entity managing the radio resources and the spectrum, which is the 6G BS in this case. The 6G network in general offers offloading and subnetwork management capabilities, while the head nodes – meaning the HC of the coordinating

device – can also offer various functionalities, in particular compute capabilities (OFF) and radio resource management capabilities (RRM). They also act as gateways (GWs) towards the larger 6G parent network for other devices within the group, especially for those with lower capabilities.

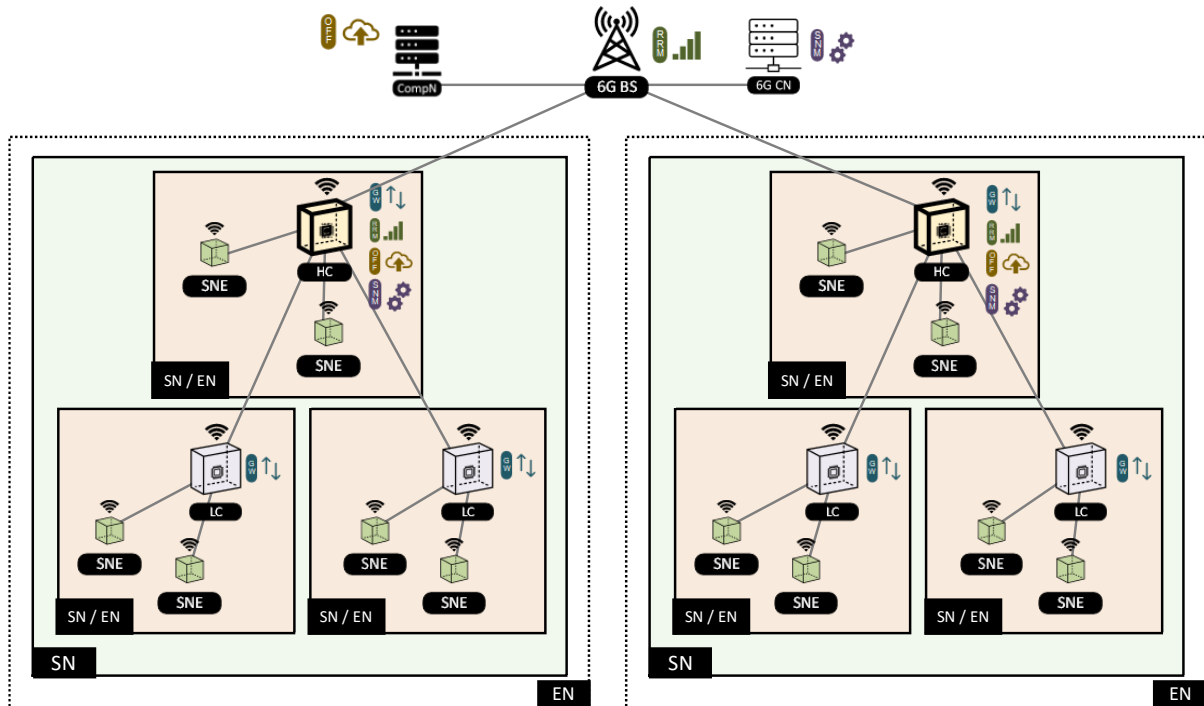

Figure 25: Subnetwork Architecture of the Subnet Co-existence in Factory Hall Use Case

Functional requirements to support the subnetwork architecture for the use case of Subnet Co-existence in Factory Hall are listed in Table 21.

Table 21: Functional Requirements of the Subnet Co-existence in Factory Hall Use Case

ID	Functional Requirement
I-4-FR-1	The system shall enable the construction of nested subnetworks, where LCs are nodes within a larger subnetwork, and at the same time, where the LCs are head nodes of a nested subnetwork.
I-4-FR-2	The overarching subnetwork's head node is an HC, and hence the system shall enable the LCs to discover HCs.
I-4-FR-3	The system shall enable subnetworks to form ad-hoc.
I-4-FR-4	The system shall enable entire nested subnetworks to be mobile, so that they can be associated to different HCs (i.e. subnetworks) in a dynamic manner.

4.5.4.6 Post-condition(s)

Upon the completion of the use case, each robot within the subnetwork is expected to execute control tasks correctly in accordance with defined KPIs, including efficiency metrics, task execution accuracy, and safety norms adherence. Transmission errors are kept to a minimum, ensuring high data integrity,

while advanced error detection and correction techniques are in place for efficient recovery. The methodology also aims to reduce costs substantially by consolidating PLCs within edge devices, thereby reducing hardware, maintenance, and upgrade costs. Moreover, this approach significantly enhances operational flexibility by allowing dynamic task assignment based on real-time requirements and quick adaptations to changes in manufacturing priorities. The system design ensures scalability to accommodate additional robots or new subnetworks and reliability for maintaining high production uptime. Security measures are integral to protect against potential cyber threats, ensuring robust protocols to guard against unauthorized access, data breaches, or interference with control functions.

4.5.4.7 KPI Aspects & Potential Requirements

The proposed use case hinges on ensuring ultra-high reliability and low latency communication, alongside the need for high throughput. This combination, referred to as high-throughput URLLC (Ultra-Reliable Low Latency Communications), is a highly anticipated aspect of 6G networks. It presents a considerable challenge due to the stringent requirements and the unprecedented levels of performance required. The scenario becomes even more complex due to its ultra-dense nature, characterized by multiple intra- and inter sub-networks in proximity. This necessitates robust and synchronized interference management strategies to ensure seamless communication. The same degree of sophistication is needed for resource allocation, where resources must be dynamically and efficiently allocated to ensure optimal network performance. Furthermore, the system must exhibit real-time adaptability to accommodate changes in production needs, robot behaviours, or network conditions. This necessitates the design of adaptive control strategies that seamlessly align with network operations, a task that could potentially require an approach to joint control and network design. These challenges underline the complexity of deploying 6G in an industrial setting and highlight the need for advanced solutions and strategies.

For this use case, various KPIs are relevant, such as communication service availability, communication service reliability, end-to-end latency, survival time, transfer interval, and user experienced data rate, as described in Section 1.3.2.

Service performance requirements:

The system must be able to support the following main KPI requirements:

- Communication service availability with a minimum target value of 99.999%
- Communication service reliability with a mean time between failures around 10 years.
- Maximum end-to-end latency less than the transfer interval value of the applications.
- User experienced data rate of at least 10 Mbits/s
- Transfer Interval of 100 μ s with minimal jitter ($\pm 0.5 \mu$ s)
- Survival time of 100 μ s
- Up to 20 devices simultaneously supported

4.5.5 Subnetwork Segmentation and Management

4.5.5.1 Description

Information technology (IT) and operational technology (OT) infrastructure can be complex, and one needs to adhere to strict IT security requirements to prevent the adverse impact of attackers and misuse. In principle, the IT infrastructure security is realized through horizontal and vertical segmentation, or, in other words, through defence by depth and security zones [30].

Vertical segmentation, or defence by depth, is realized by multiple security layers starting from the Internet (unprotected) to multiple manufacturing layers to the segment related to elements requiring the highest security standards, e.g., a production machine. The smallest entity or zone can be related to one manufacturing cell or a single robot, which themselves are comprised of several components such as a PLC, and sensors and actuators. In addition to vertical segmentation, horizontal segmentation provides isolation between different parts of the factory or production IT environment, i.e., in the physical and logical sense, that do not depend on each other in very short time cycles and can, therefore, communicate through dedicated services that operate at higher zones. Zones can comprise different machines of separate value streams, entire production lines, or segments that provide services to multiple machines in lower zones (at lower security layers).

Through the combination of defence by depth and zones, many different IT architectures can be implemented and usually they are specifically tailored to the type of production or manufacturing. Moreover, conduits are realized to allow well-defined communication only between pre-defined nodes to enable communication between zones only for a certain purpose, further adding to the complexity of the IT infrastructure.

The concept of segmentation with zones and conduits needs to be considered during the design, setup and management of subnetworks. This holds especially true in the context of swarm production, where different manufacturing machines perform ad-hoc actions to achieve a certain, temporary production goal. In such a case, zones may be reconfigured dynamically, which includes managing the assets and their segments, like adding a component to a segment and removing it from another one or managing and configuring the segments themselves.

In this regard, this use case can be comprised of all other use cases, while it focuses on the security and management aspects on a higher abstraction layer, in particular at functional requirements rather than performance requirements compared to the other use cases.

4.5.5.2 Pre-condition(s)

There is a certain target factory layout with a physical and logical plan of factory assets incl. sensors, actuators, robots, PLCs, machines, etc. A subset of these assets needs to be put together in the form of a subnetwork as they will jointly perform a production target along a value chain.

4.5.5.3 Operation Flow

1. A user creates a new instance of a new subnetwork and configures it.

2. A user adds 3GPP-based assets to the subnetwork and configures the communication relationships for each pair in this group as well as between these assets and other assets outside of this subnetwork through another external tool with appropriate APIs.
3. A user adds non-3GPP assets to the subnetwork and configures the communication relationships. This could be a special case, in which the asset has no cellular connectivity but used a different non-3GPP access technology to establish communication links. This could include WLAN, Ethernet and others, and might involve corresponding inter-working functions.
4. A user adds a soft PLC as a software instance on a compute node to the subnetwork.
5. A user activates the subnetwork so that all necessary network functions are instantiated, e.g., at the subnetwork AP.

4.5.5.4 Deployment Scenarios

The deployment scenarios depend very much on the type of production, i.e., the types of products to be manufactured. For example, the production of vehicles usually looks very different from that of semiconductors, both, in terms of spatial dimensions of the production processes and the structure of the value streams across the factory. However, more often than not the value stream structure is an indicator also for the IT infrastructure, as one needs to protect the IT at least on a value-stream level. This means that subnetworks can, on the highest hierarchical level, be defined per value stream, which often comprises at least one production line. Each production line is composed of multiple processing steps, each of which can be assigned to a certain machine, robot, production cell, etc. On this lower level, a machine (as in the first three use cases) can represent another hierarchy of subnetworks, which include controllers, sensors and actuators. Per factory floor, several ten production lines are possible with up to three or four horizontal levels or hierarchies. The typical footprint of a production line can be assumed to be 25 m by 10 m. Also, the number of nodes within a production cell or of a robot can vary significantly. Details can be found in the first three industrial use cases.

4.5.5.5 Post-condition(s)

The subnetwork and all assets are fully operational, and all security requirements are fulfilled.

4.5.5.6 KPI Aspects & Potential Requirements

The challenges for the design and manageability of subnetworks in the context of manufacturing IT security and factory asset management can be summarized as

1. Flexibility of the subnetwork architecture:
The subnetwork architecture should be flexible enough to realize any possible setup of a combined horizontal and vertical segmentation with intra- and inter-subnetwork communication and where also non-3GPP end devices are supported.
2. Performance:
Sufficient wireless performance (see other industrial use cases) for temporary communication with a certain purpose between nodes in different zones / subnetworks (whitelisting) needs to be ensured while security and isolation is guaranteed at the same time.

3. Manageability:

Due to the potentially very large number of subnetworks in a factory, managing them can become complex and expensive. Appropriate management and exposure functionalities need to be provided.

From the operation flows and challenges above, industrial subnetworks need to fulfil several functional requirements. First and foremost, the overall system shall enable easy and efficient manageability of subnetwork membership of nodes within and across subnetworks, also by third parties incl. the user (factory personnel), which includes adding, configuring, and removing of nodes and subnetworks. This necessitates exposure of node and subnetwork management functionalities towards an Operation & Administration Maintenance (OA&M) and third-party applications, as well as manageability (enabling and disabling) of intra- and inter-subnetwork communication relationships on a per-node/group basis, with the possibility to also realize nested subnetworks.

Regarding security, secondary authentication support is required, which ideally should be subnetwork specific. Security for insecure IT end devices with limited encryption capabilities is important, as many sensors and actuators have very limited capabilities for application-level security.

Due to the flexibility requirements of future industrial networks, multi-subnetwork membership of a node and the integration of non-3GPP nodes, such as nodes that are connected via Ethernet or WLAN, into a subnetwork, i.e., integration with respective interworking functions, become important. Furthermore, servers and compute nodes (SW instances) as parts of a subnetwork should be supported, while network functions should be instantiated efficiently per subnetwork, i.e., efficient usage of resources for these network functions, e.g., at the subnetwork AP.

The functional requirements are summarized in Table 22.

Table 22: Functional Requirements of the Subnetwork Segmentation and Management Use Case

ID	Functional Requirement
I-5-FR-1	The system shall enable dynamic formation/grouping of subnetworks (adding, removing, configuring) through exposure functionalities.
I-5-FR-2	The system shall enable the configuration of allowed or forbidden communication relationships for each pair of HC, LC or SNE.
I-5-FR-3	The system shall provide AAA (authentication, authorization, accounting) functionalities dedicated to subnetworks.
I-5-FR-4	The system shall enable secondary authentication for HC, LC, and SNE.
I-5-FR-5	The system shall provide interworking functions to manage non-3GPP connections.

4.6 CHARACTERIZATION OF INDUSTRIAL TRAFFIC

Characterization of industrial traffic is of paramount importance for the design and evaluation of wireless technology components of industrial subnetworks. The 3GPP has identified several potential

use cases for communication in vertical domains and corresponding requirements [1][26], and industry fora such as 5G-ACIA have spent a significant effort in the categorization of different traffic types related to a plethora of industrial applications such as motion control, mobile control panels, closed loop process control. Traffic behavior is very diverse, and a general categorization presented in [32] includes deterministic periodic traffic, non-deterministic traffic and burst traffic, along with attributes such as message size, transfer interval and data rate, derived for specific applications. The SNS project TIMES has also identified modelling parameters for real time traffic for motion control, distinguishing between isochronous (i.e., periodic) and non-isochronous traffic; also, characteristics of traffic for vision systems and non-real data collection were reported [33]. Experimental characterization in industrial setups presented in [27] has highlighted the heterogeneity of traffic in industrial settings, including the limited match with typical models commonly used in the scientific literature such as exponentially distributed packet arrivals. Traffic type is indeed not only dependent on the service and underline protocols, but also on the specific industrial product and its data generation characteristics. Still, technology components are designed by relying on commonly agreed traffic assumptions, though they might not exhaustively cope with the actual characteristics of industrial products in real-world settings.

In this section, we present an analysis of experimental industrial traffic analysis carried out at the 5G Smart Production Lab at Aalborg University, Denmark. Our goal is to provide an experimental evidence of the traffic characteristics for challenging wired use cases, for the sake of highlighting the need of a wireless system beyond the capability of 5G, to be potentially addressed by in-X subnetworks. Also, we aim at deriving guidelines for modelling industrial data traffic, to be used in simulations in WP3 and possibly WP4. Measurements are carried out following a similar procedure as in [27], with a traffic sniffer inserted in between the control computer and the corresponding industrial equipment, and interfaced with the Ethernet links. The sniffer has a processing delay jitter lower than 10 μ s.

DUT Motion control

We first consider the case of motion control. An operator runs a program on a PC that controls the position and motion of a DUT on a magnet table. The program sends commands to a programmable motion controller to control the DUT over socket (TCP/IP).

Traffic traces are shown in Figure 26 (a). It is clear from the figure that packet sizes take only a few discrete values. We distinguish between small (below 90 bytes), medium (between 90 and 140 bytes) and large packets (above 140 bytes). The empirical cumulative distribution function (ECDF) of the interarrival times is shown in Figure 26 (b). Traffic shows a broad interarrival distribution; small and large-sized packets have tighter interarrival times than medium-sized packets. Inter-arrival times for small and large packets have a good match with an exponential distribution (with different rate λ) only on the high-end of the distribution, while part of the packets exhibit periodic arrivals with periodicities of ~ 2 ms and ~ 0.3 ms. Inter-arrival times with medium packets can only be roughly approximated with an exponential distribution.

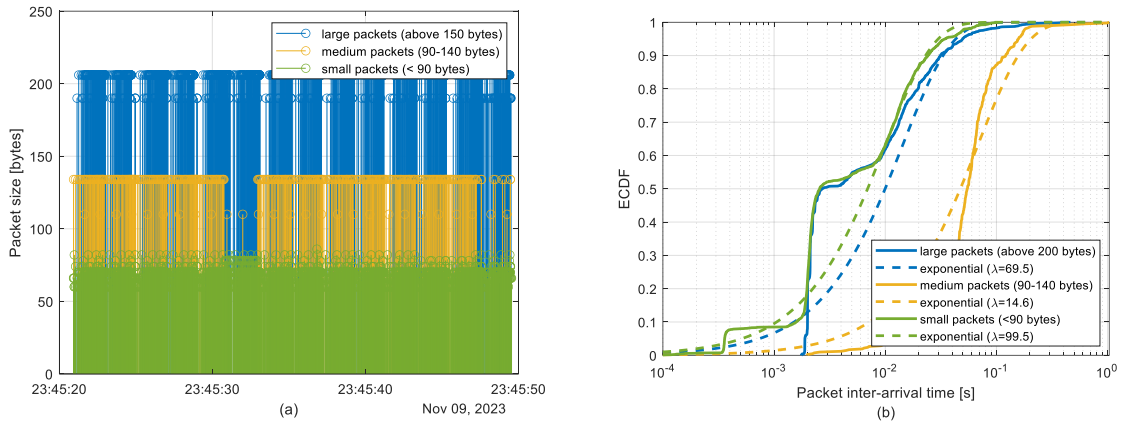

Figure 26: Traffic traces (a) and distribution of inter-arrival times (b) for motion control.

Robot control

We characterize here the control traffic between a PLC and a robot arm during cutting operations. Communication here is using Ethercat protocol, and the recorded traces are for *eth.ecatf._ws.short*, *eth.ecatf.ecat*, *eth.ecatf.ecat.DATA*, telegrams. Recorded traces are shown in Figure 27 (a). The *eth.ecatf.ecat.DATA* telegrams are all 60 bytes, while the *eth.ecatf._ws.short* telegrams are either 1052 or 1336 bytes. The *eth.ecatf.ecat* telegrams range between 147 and 416 bytes, with more than 90% of the occurrences of 147 bytes. The empirical cumulative distribution function of interarrival times (Figure 27 (b)) highlights the nearly periodic behavior of the traffic components. In particular, the large *eth.ecatf._ws.short* telegrams are transmitted at a period of either ~ 0.8 ms, or ~ 0.5 ms and 0.3 ms, with a minor jitter, though telegrams transmitted at a tighter timing also exist. Around 45% of the while the *eth.ecatf.ecat* telegrams have a periodicity of ~ 10 ms, while the rest are transmitted at more frequent timings. Most of the small *eth.ecatf.ecat.DATA* are transmitted at tighter periodicity, significant below 100 μ s, though the exact value might be affected by the limited precision of the sniffer.

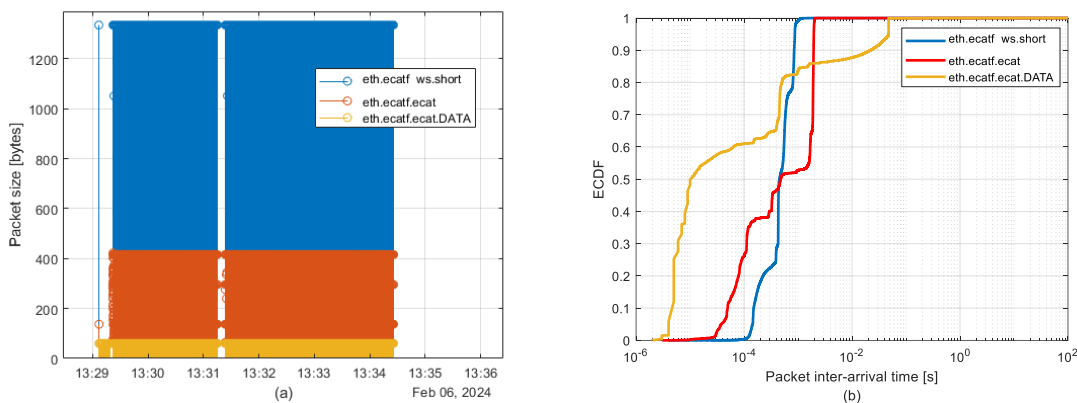

Figure 27: Traffic traces (a) and distribution of inter-arrival times (b) for robot control.

Sensor camera

We aim here at characterizing here the traffic generated by a professional sensor camera that projects a laser line onto the object to be detected and generate an accurate profile of the object itself.

The traffic generated from the camera is a mix of TCP traffic (69% of the packets) and UDP traffic (31% of the packets).

Figure 28(a) shows the time traces of the UDP packets, highlighting the clear distinction between small packets (below 400 bytes) and large packets (above 400 bytes), while the distribution of the packet interarrival times distribution is in figure 28(b), respectively. Large packets have a generally constant size of around 500 bytes, with few larger outliers, while small packets have a fairly broader distribution, with most of the occurrences in the order of 350 bytes. Packet interarrival times for small packets can be approximated fairly well by an exponential distribution (with rate $\lambda=4.49$ packets/s), while large packets have tighter interarrival times and exhibit a “stepped” behavior, highlighting potential periodicity of the underline traffic at different tight periods. Small packets have interarrival times below 1 ms in 10% of the occurrences, while large packets in around 70% of the occurrences.

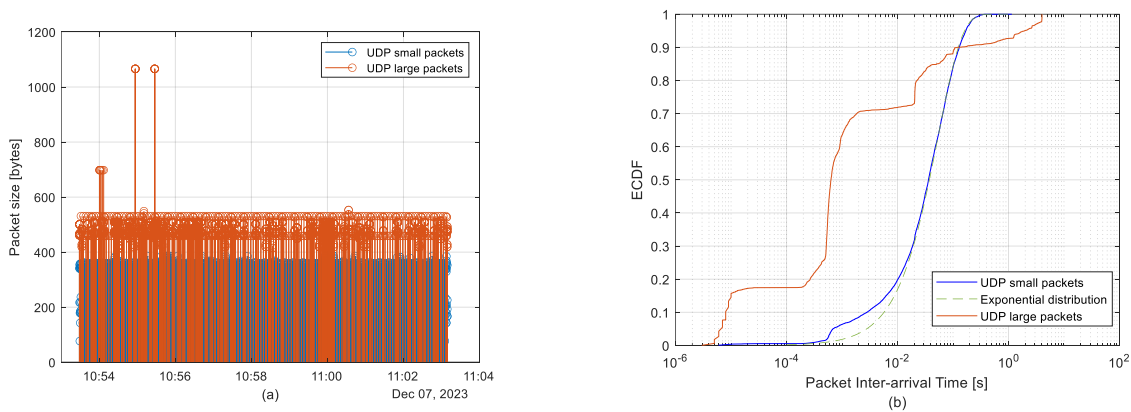

Figure 28: Traffic traces (a) and packet interarrival distribution (b) for UDP traffic generated by sensor camera.

Traces and distribution for TCP traffic is shown in Figure 29. TCP traffic has a bursty behavior as it is absent from several minutes. Such behavior corresponds to the combination of non-periodic and bursty traffic as highlighted in [32]. As expected, packet sizes are generally higher than in the UDP case, with outliers overcoming the 10 kbytes. Packets sizes have discrete nature, with a limited set of recurrent values. Interarrival times are also tight and show a decent match with an exponential distribution (with rate $\lambda = 12.13$ packets/s derived from empirical data) only above the median value; for the lower part of the empirical distribution, values are stricter than the exponential distribution, possibly due to some underlying correlated packet generation process.

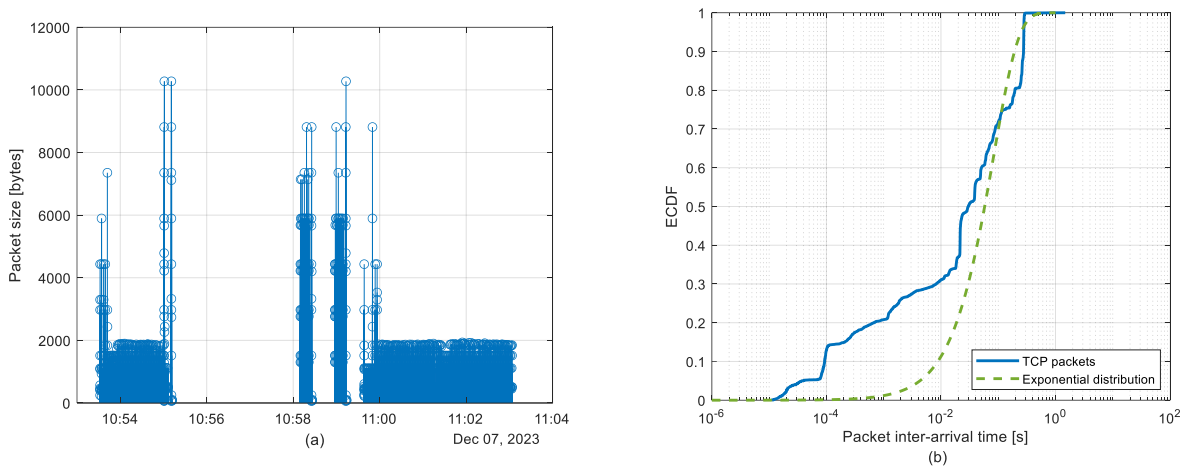

Figure 29: Time traces (a) and distribution of packet interarrival times (b) for TPC traffic generated by sensor camera.

Second sensor camera

We characterize now the traffic generated by a different sensor camera, able to scan 3D objects. Communication here is using Ethercat protocol, and the recorded traces are for *eth.ecatf._ws.short*, *eth.ecatf.ecat*, *eth.ecatf.ecat.DATA* telegrams. Recorded traces are shown in Figure 30 (a). Traffic behavior appears here similar to the one of the robot control case, where also Ethercat is used. The *eth.ecatf.ecat.DATA* telegrams are all 60 bytes, while the *eth.ecatf._ws.short* telegrams are all 1336 bytes. The *eth.ecatf.ecat* telegrams range between 134 and 416 bytes, with more than 90% of the occurrences of 147 bytes. The empirical cumulative distribution function of interarrival times (Figure 30 (b)) highlights the nearly periodic behavior of the traffic components. In particular, the large *eth.ecatf._ws.short* telegrams are transmitted at a period of either ~ 0.3 ms, or ~ 8 ms, while the *eth.ecatf.ecat* telegrams have a periodicity between 0.4 ms and 0.6 ms. Same as for the robot control case, most of the small *eth.ecatf.ecat.DATA* are transmitted at tighter periodicity, significant below 100 μ s, though the exact value might be affected by the limited precision of the sniffer.

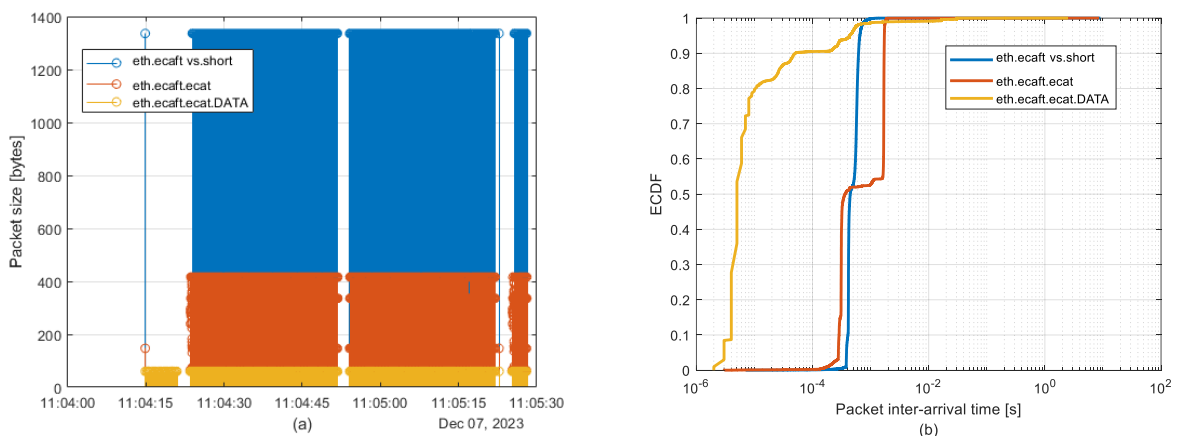

Figure 30: Time traces (a) and distribution of packet interarrival times (b) for traffic generated by the second sensor camera.

General considerations and recommendations

The example above highlights how the industrial traffic characteristics may be very diverse and strongly dependent on the specific equipment, even for a same use case. Common identified characteristics, also consistent with previous literature reported above, are the discrete nature of the packet sizes regardless of the underline protocol, the presence of periodic flows with diverse periodicity, interarrival times lower than 1 ms.

Consistently to the example described above, we recommend the following assumptions for the generation of traffic related to industrial subnetworks¹:

- Generating packet sizes having a limited set of options.
 - o Packet from robot control can be in the range 60-1300 bytes
 - o Packets for use cases involving visual inspection (with laser cameras) can be in the range 200- 2kbytes. Also, sporadic large packets exceeding 8 kbytes can also be considered.
 - Eventually, one may distinguish between UDP-type traffic, and TCP-type traffic. UDP packets may not exceed 600 bytes, while TCP packets can be larger, including a larger number of outliers.
- Periodic traffic flows can be periodic, with periodicities ranging from ~0.1 ms to 100 ms. Tight periodicities are typically associated to small packets.
- A Poisson traffic model with exponential inter-arrival times can be used for modelling flows, though time correlated traffic flows with tighter arrivals can be considered.
- Composite traffic, integrating periodic, Poisson and time-correlated flows can be considered.

4.7 POSSIBLE INDUSTRIAL SUB-CATEGORIES

As highlighted already in Section 4.1, the different use cases follow a somewhat hierarchical order, in which the terms ‘In-X entity’ and ‘device’ have different meanings. Table 23 gives an overview of the hierarchical levels in the form of industrial sub-categories according to the (semi-)static vs. dynamic formation of subnetworks and small vs. large spatial footprints.

Table 23: Hierarchical Setup of Industrial Sub-Categories and Use Cases

Industrial sub-category	Communication area (up to)	In-X entity	Device/Node Examples	Use Cases
A – Static setup / Small footprint	Short-range, e.g., in a 3-5 m ³ volume	Robot, machine, or production cell	Sensors, actuators, PLCs, HMIs, cameras	Robot control, Unit test cell, Visual inspection cell
B – Dynamic setup /	10 m x 10 m x 5 m (per subnetwork)	AGV group, production line,	AGVs, robots	Robot swarms

¹ It is not included here the traffic generated by video cameras for visual inspection, as this follows typical characteristics of 4K video streaming

Large footprint		material/asset supermarket		
C – Management / Static and dynamic setups	25 m x 10 m x 5 m (per segment), with nested subnetworks, e.g., production cells	Production line (e.g., with 20 production cells), factory network segment (e.g., with up to 10 production lines)	Sensors, actuators, PLCs, HMIs, cameras, AGVs, robots, machines	Factory asset management

4.8 6G CHALLENGES AND 6G-SHINE TECHNOLOGY COMPONENTS RELATED TO INDUSTRIAL SUBNETWORK

We have seen that industrial use cases impose very stringent requirements on industrial subnetworks, which include KPIs targeting extremely low latency, cycle times and transfer intervals, as well as very high reliability. In addition, the broad variety of in-X entities (see Table 23), ranging from small-footprint robots to highly dynamic formations of AGV or robot swarms to entire production lines, necessitates architectural and management capabilities far beyond what exists in current wireless networks.

The following 6G-SHINE's TCs (see Table 24) are identified as relevant to address the above challenges.

Note: We do not intend to evaluate all the following TCs for a given use case in the other technical WPs. The TCs will be evaluated for specific selected use cases, and eventually it may be elaborated on how these TCs can also be used in the other use cases.

Table 24: Technical Components (TCs) Addressing the Use Case Challenges

Technology component (TC)	Use cases	Explanation
TC1. In-X data traffic models	Robot control, Unit test cell, Visual inspection cell	Traffic models are derived based on previous experience and new measurements in industrial lab facilities.
TC2. Channel models for in-X scenarios	Robot control, Visual inspection cell, Robot swarms	Channel models will be derived upon measurement campaigns in industrial lab facilities. Also measurements for RIS will be performed.
TC3. Sub-THz system models	Robot control, Visual inspection cell	Developed sub-THz system models can be applied for providing reliable low latency links in line of sight conditions.
TC4. Ultra-short transmissions with extreme reliability	Robot control, Unit test cell	Support of fast communication cycles (with duration below 100 μ s) require physical layer enhancements beyond 5G
TC5. Analog/hybrid beamforming/beamfocusing	Robot control, Unit test cell, Visual inspection cell	This TC can be used in case antenna arrays can be installed in the plant to control robot parts. It might

		be more suited at high frequencies (e.g., sub-THz) as small factor arrays are possible.
TC6. Jamming-aware native PHY design	Robot control	Relevant for critical control operations –including life-critical operations- which cannot be interrupted
TC7. RIS enhancements	Robot control, Unit test cell, Visual inspection cell, Robot swarms	Relevant in case a RIS can be installed in proximity of robots and machineries, to control propagation environment and counteract blockage effects
TC8. Intra-subnetwork macro-diversity	Robot control, Unit test cell, Visual inspection cell, Robot swarms	Relevant for those subnetworks featuring multiple APs that can be used for providing redundant radio link for enhancing reliability
TC9. Flexible/full duplex scheduler	Robot control, Unit test cell, Visual inspection cell	Relevant for subnetworks supporting different traffic types, e.g. control loops with different cycle duration, or multiplexing of low data rate traffic (e.g. control loops with small packets), with high data rate video feeds
TC10. Predictive scheduler	Robot control, Unit test cell, Visual inspection cell	Relevant for control applications featuring traffic with a predictive pattern. The usage of predictive schedulers allows for improved promptness, and reduces signalling overhead
TC11. Latency-aware access in the unlicensed spectrum	Robot control, Unit test cell, Visual inspection cell, Robot swarms	Relevant for unlicensed spectrum operations, when services with deterministic latencies are to be supported (e.g., control loop)
TC12. Centralized radio resource management	Robot control, Visual inspection cell, Factory asset management	Relevant for industrial subnetworks in the coverage area of a 6G enterprise network, that are able to signal to the enterprise network information on the locally experienced channel quality and interference levels.
TC13. Distributed/hybrid radio resource management.	Robot control, Visual inspection cell	Relevant for those subnetworks with sporadic or no connection with an enterprise network.
TC14. Jamming detection and mitigation	Robot control	Relevant for critical control operations –including life-critical operations, that cannot be interrupted.
TC15. Hybrid management of traffic, spectrum and computational resources	Visual inspection cell, Robot swarms	Relevant for subnetworks handling diverse traffic types, where the non-critical traffic can eventually be offloaded to an edge cloud or central cloud server
TC16. Coordination of operations among subnetworks in the same entity	Subnetwork Segmentation and Management	Relevant for architecture and the overarching management and coordination of multiple, nested, subnetworks in a factory environment.

5 IN-VEHICLE SUBNETWORKS CATEGORY

In-vehicle networks are necessary to exchange data between sensors, actuators, control units, and computing systems. Due to the critical timing, reliability, and safety requirements of automotive functions and services, in-vehicle communications nowadays mostly rely on cable links. Cabled communications entail careful planning and an increase in the weight of vehicles. The shift towards software-based Connected and Automated Vehicles (CAV) and Electric Vehicles (EV) increases interactions between in-vehicle functions and places higher demands on in-vehicle networks that should be able to support increasing levels of reconfigurability in software-defined vehicles. Adapting cabled-based in-vehicle networks to meet evolving needs might be challenging since cable harness is designed with specific configurations and limited flexibility, making it harder to accommodate new needs. Replacing cables with in-vehicle wireless links could facilitate the evolution of in-vehicle networks and enable the incorporation of new functionalities through the vehicle's lifespan, in addition to reducing the vehicle's weight and reducing fuel or battery consumption. However, this must be done without compromising the automotive service levels, and in particular reliability and safety.

One of the focus points in 6G-SHINE is designing and developing key technology components for short-range, flexible, and low-power subnetworks that could be implemented in vehicles to facilitate a transition towards more pervasive in-vehicle wireless networks. Significantly, Hexa-X-II has also outlined a use case involving wireless in-vehicle networks [36]. 6G-SHINE solutions will also benefit from their integration into the 6G 'network of networks, enabling seamless connection to the cloud. In this context, this section identifies use cases and scenarios of interest where wireless links can be employed for communication between in-vehicle elements (sensors, actuators, and control and computing units) and 6G network elements (edge, cloud). The selection of use cases is technology-oriented given the large timespan of development of vehicular platforms and the objective to provide a comprehensive set of options for future flexible in-vehicle network designs.

5.1 STATUS QUO ON IN-VEHICLE NETWORKS AND E/E ARCHITECTURES

In-vehicle networks and Electrical/Electronic (E/E) architectures that connect sensors and actuators with ECUs are evolving from flat or distributed CAN-based networks to hierarchical networks [38][39][40] (see Figure 31). Traditional E/E architectures incorporate one ECU for each in-vehicle electronic function with a very specific control task, and a direct interconnection among them (see Figure 32.a). This approach requires new ECUs and interconnections when new sensors or actuators are required. However, the large increase of electronic functions introduced in vehicles to support driver assistance systems challenges the scalability of traditional E/E architectures.

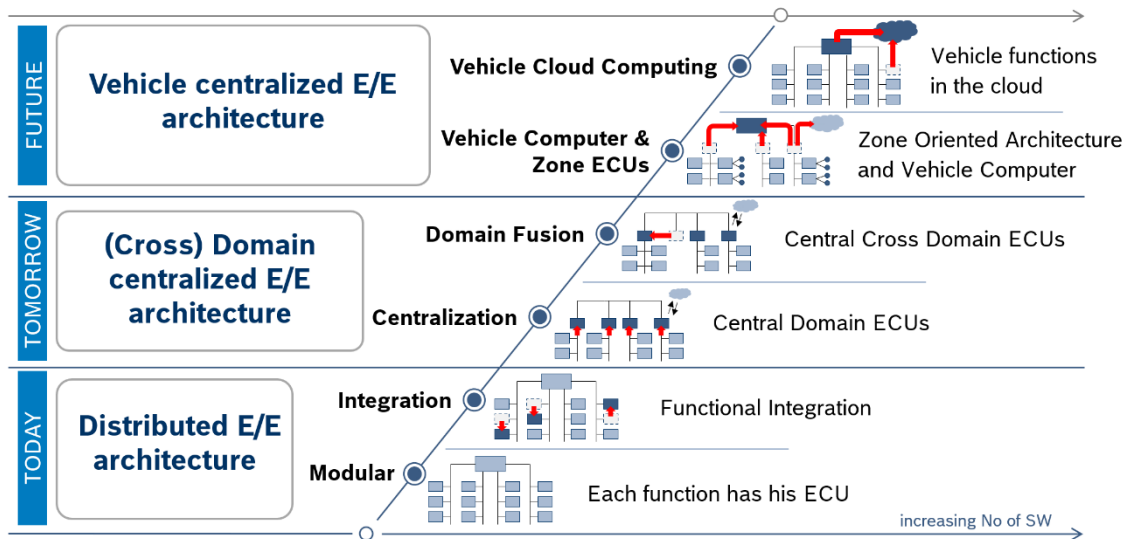

Figure 31: Evolutionary Trends in E/E Architecture Development (figure taken from [41])

5.2 IN-VEHICLE EVOLUTIONARY TRENDS

A first evolution of in-vehicle networks includes domain-based E/E architectures (see Figure 32.b) and it is motivated by the growing number of automotive applications that require interconnecting functions with increasing demands. High bandwidth data flows and lower and deterministic latency requirements (see Integration and Centralization in Figure 31) are typically required from relevant applications. In domain-based E/E architectures, ECUs group sensors and actuators based on functionalities or domains (e.g., infotainment, powertrain, assisted driving, etc.). This logical definition of the E/E architecture simplifies the design of ECUs and in-vehicle networks that need only to handle the traffic and address the requirements of one domain.

In the domain-based E/E architecture, the interconnections between sensors and actuators that are in different physical locations of the vehicle are managed by domain-specific technologies such as CAN, FlexRay, Local Interconnect Network (LIN), Media Oriented Systems Transport (MOST), or Automotive Ethernet, attending to the specific requirements of each domain. As a result, different cables need to be routed through the vehicle to interconnect all the sensors and actuators of each domain. In addition, the domain-based E/E architecture relies on cross-domain communication via a central gateway/controller to interconnect domains and the functionalities they support. The disassociation between the logical/functional and physical distribution of sensors and actuators within the in-vehicle network is the main drawback of the domain-based E/E architecture. This challenges the scalability of domain-based E/E architectures from the architecture and topology (and cable cost) point of view considering the increasing number of sensors and actuators that are to be integrated into in-vehicle networks with the “softwarization” of vehicles and the gradual introduction of AD functions.

AD will not only challenge the design of future E/E architectures but also the in-vehicle networking and communication infrastructure required to simultaneously support control loop applications with strong real-time and bounded requirements, applications with higher bandwidth demands but relaxed timing

constraints (e.g., software updates or multimedia streaming) and AD functions supported by high-resolution sensors requiring high data rates, and strict reliability and timing.

“Zonal network” E/E architectures (see Figure 32.c) represent an alternative evolution to increase efficiency while the complexity and functionalities of vehicles expand as we progress to AD. Zonal E/E architectures group embedded devices and electronics by physical location rather than logically or per domain (Domain Fusion and evolution towards Zone ECUs in Figure 31). Defining zones within the architecture of the vehicles which have their own ECU or zonal gateway controller increases the flexibility, performance, and scalability compared to the domain-based E/E architecture. ECUs distribution changes from logical functionality or domain to physical zone inside the vehicle, solving the scalability issues identified in domain-based E/E architectures. The zonal E/E architecture locally connects sensors, actuators, and functions to zonal ECUs or gateway controllers that are physically and strategically distributed within the vehicle. This also reduces the cable length compared to the domain-based E/E architecture [42].

The zonal E/E architecture helps in addressing some of the limitations of the domain-based E/E architecture, but it also brings new challenges to overcome. In domain-based E/E architectures, each ECU is only in charge of handling the traffic and requirements of sensors and actuators of one domain. A zone ECU needs to support sensors and actuators that are physically placed in the same area but belong to different functionalities and domains (Domain Fusion). This implies that zonal ECUs need to handle mixed traffic of different functionalities and with different requirements. The evolution towards zonal E/E architectures increases the design complexity of ECUs with the support of heterogeneous and cross-domain functionalities, which are distributed and must be synchronized across several vehicle zones. With the aim to address these challenges, the zonal E/E architecture relies on a high-speed automotive Ethernet backbone to connect zonal ECUs together, as well as to the vehicle’s central brain platform/server, that is referred to as HPCU or Vehicle Computer. The HPCU has advanced processing (and Artificial Intelligence) capabilities and is in charge of doing the necessary processing of complex vehicular functions [43].

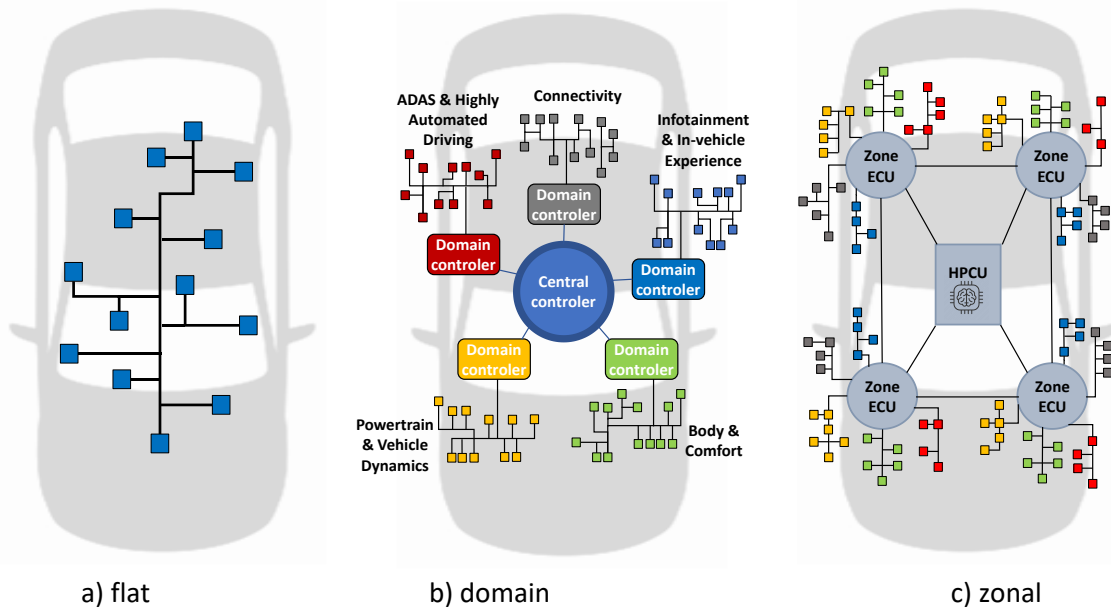

Figure 32: Evolution of vehicular E/E architectures

The evolution of the zonal E/E architecture continues, with a noticeable trend towards a more centralized and zone-oriented E/E architecture [43][44]. This evolution is characterized by the centralization of data streams using a reduced number of HPCUs that are strategically distributed throughout the vehicle. HPCUs can refer for instance to independent platforms/nodes for ADAS (AIP) or motion integration (MIP) [44]. This contrasts with the many individual ECUs that are utilized in former E/E architectures for control and data processing. The centralized, zone-oriented E/E architecture envisions that zonal ECUs perform limited processing for automotive applications or functions. Instead, they collect data generated by sensors (raw or processed) and forward them to a central HPCU that does most of the necessary processing. It is also envisioned that the sensors and actuators have the capability of bypassing the zonal ECUs to directly connect with the HPCU in specific cases. To ensure strict requirements and service levels of automotive applications and functions, the centralized, zone-oriented E/E architecture might rely on a communication network that uses high-speed automotive Ethernet with Time Sensitive Networking (TSN) capabilities [45] for the direct communication between HPCUs and the zonal ECUs, sensors, and actuators.

This evolutionary architecture also considers the integration with the cellular network for over-the-air updates [46] and the offloading of complex functions to the cloud (Vehicle Cloud Computing in Figure 31). In this case, a CCU acts as a gateway between the in-vehicle network and the cellular network unifying the high-processing and AI capabilities on both ends.

5.3 6G-SHINE REFERENCE IN-VEHICLE FRAMEWORK

The description of the 6G-SHINE's in-vehicle use cases provided below takes as a reference the in-vehicle architecture evolutionary trends described in Section 5.2, which are characterized by a centralized, zone-oriented E/E architecture. Without loss of generality, Figure 33 captures a logical representation of such centralized, zone-oriented E/E architecture. Note that this logical representation does not represent a

specific zone of the vehicle where the sensors/actuators, zonal ECUs and HPCU are located. It is also not limited by the number of elements (sensors/actuators, zonal ECUs, HPCU) represented in the figure. In addition, Figure 33 does not provide intentionally a complete view of the in-vehicle E/E architecture. On the contrary, the logical representation of the centralized, zone-oriented E/E architecture reported in Figure 33 is intentionally left open and general with the aim of not being restricted to a specific vehicle design.

Figure 33 shows that the sensors and actuators can utilize different cabling technologies (e.g., CAN, FlexRay, LIN, MOST, or Automotive Ethernet; represented by different colours) to connect to a zone ECU. The possibility that the sensors and actuators bypass the zone ECU to connect directly to the HPCU is also represented in the reference E/E architecture shown in Figure 33. If this is the case, it is considered that the cable technology utilized for such interconnections is the high-speed automotive Ethernet link (with TSN capabilities) that is also used between the zone ECUs and the HPCU.

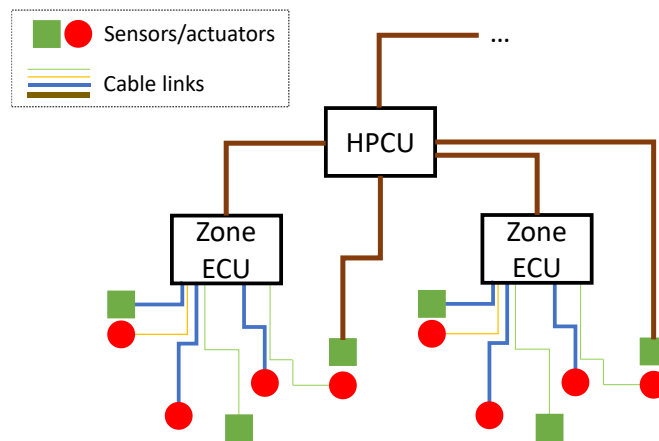

Figure 33: 6G-SHINE reference in-vehicle E/E architecture that captures the evolutionary trends towards centralized, zone-oriented E/E architectures.

5.4 BENEFITS AND CHALLENGES OF IN-VEHICLE SUBNETWORKS

6G-SHINE targets the design of 6G-native in-vehicle wireless subnetworks capable to provide dependable service levels similar to those reached with cables. Despite recent advances in wireless technologies, such as (Beyond) 5G and Wi-Fi 6 developed in 3GPP and IEEE standardizations, respectively, it remains still a significant challenge to deliver wire-equivalent bandwidth and reliable deterministic wireless communications to be used in time-safety critical systems like those implemented inside vehicles.

The 6G-SHINE's in-vehicle subnetworks will also need to efficiently support multiple traffic flows with varying requirements, including deterministic performance, which is critical in sustaining AD functionalities, and increasing data rates as AD sensing units (e.g., cameras, lidars, or radars) are integrated into vehicles. To this aim, 6G-SHINE in-vehicle subnetworks will benefit from the native high-processing and AI capabilities available in central controllers or HPCU for their operation and deployment.

In addition, 6G-SHINE in-vehicle subnetworks will benefit from their integration into the 6G network of networks from inception to provide native connections to the cloud. This will foster opportunistic offloading and vehicle-network-cloud cooperation to support advanced functionalities critical for AD and the continuous evolution and advancement of vehicles. These concepts will also be an enabler for a framework for reliable radio resource management supported by the network infrastructure for both, intra- and inter-vehicle subnetwork interference management.

The use of 6G in-vehicle subnetworks will offer the possibility to gradually replace more cabled in-vehicle connections with wireless solutions that are currently limited to those that cannot be reached with cables (e.g., TPMS). This has the potential to reduce the cost and weight of vehicles (increased with the introduction of electric vehicles) and may lower consumption and emissions (e.g., fuel and battery).

In-vehicle subnetworks also target high-reliability designs due to the advancements in autonomous driving and increased integration of sophisticated systems. To achieve this level of reliability, it is essential to utilize redundant connections. 6G-SHINE wireless subnetworks can provide an alternative or complementary solution to address this reliability challenge by providing a combination of redundant in-vehicle wireless and wired connections.

In addition, 6G-SHINE in-vehicle subnetworks will provide additional means to evolve and improve new functionalities over the life of vehicles with the softwarization of vehicles. The introduction of 6G-based in-vehicle subnetworks fuels such evolutions with additional levels of flexibility for in-vehicle connectivity that can overcome potential limitations from cabling planned at the time a vehicle is designed (the lifetime of a vehicle is currently around 12 years).

5.5 KVIs OF IN-VEHICLE SUBNETWORKS

The common KVIs applicable to all use-cases are elaborated in Section 1.3.3. In this section, the specific KVIs of in-vehicle subnetworks are described. 6G-SHINE aims to assess the social impact and value of the 6G in-vehicle wireless subnetworks across various vertical sector applications, including the automotive industry. Sustainability will be one of our primary concerns. The functionalities and technologies of vehicles are continuously advancing and evolving through the introduction of new connected and automated systems for self-driving and electric vehicles. The adoption of flexible, low-power, and short-range in-vehicle wireless subnetworks will facilitate the update and evolution of in-vehicle networks and architectures, enabling them to adapt to these advancements, thereby extending the lifetime of vehicles and promoting a circular economy (i.e., economic sustainability).

Furthermore, gradually replacing more wired in-vehicle connections with wireless solutions may contribute to reducing the cost and weight of vehicles, as well as to lowering energy consumption (fuel of battery) and CO₂ emissions (i.e., environment sustainability). In line with the 6G ‘network of networks’ vision, 6G-SHINE also aims to integrate the in-vehicle subnetworks, which presents new technological opportunities and fosters substantial economic growth and business value. This integration increases flexibility in service provisioning, including the ability to offload complex functions/services to the edge

or the cloud and deliver over-the-air updates for device’s firmware. By distributing the traffic and computational load between in-vehicle subnetworks and the broader 6G network, optimized resource allocation can be achieved, resulting in an overall reduced energy consumption.

The examples of the KVI of in-vehicle subnetworks and their enablers are summarized in Table 25.

Table 25: Summary of KVI & Its enabler of In-vehicle subnetwork Use Cases

KV	KVI	KVI Enabler
Social	Improve road safety (minimize number of accident)	High number of connected sensors and actuators;
Environment	Lighter vehicle Improving operation efficiency to minimize pollution (e.g., utilizing sensors data)	
Economic	Create business opportunity (e.g., creating the platform, sensor data analytics) Improve the innovation in the car industry (e.g., toward autonomous car driving) Reduce cooper usage	Low latency and high reliability communications

5.6 IN-VEHICLE SUBNETWORKS USE CASES

The following subsections describe the identified in-vehicle use cases. For each use case, we describe the elements that intervene and the automotive functions or services that are represented. We also identify pre-conditions, the operational flow, and post-conditions when the use case is correctly implemented. Finally, we report the main potential key performance indicators and requirements of the use cases.

5.6.1 Wireless Zone ECU: In-vehicle wireless subnetwork zone

5.6.1.1 Description

This technology-oriented use case is aimed at enabling wireless zonal ECUs for the 6G-SHINE’s reference, centralized, zone-oriented in-vehicle E/E architecture (see Section 5.3). As it is shown in Figure 34, and without loss of generality, the considered in-vehicle zone is characterized by the presence of sensors and actuators that might support automotive functions and systems from different in-vehicle domains (e.g., ADAS, powertrain, etc.). In the in-vehicle zone, there is also a zone ECU that manages and controls the sensors and actuators that are located in this zone. The zone ECU is connected to the HPCU through the automotive Ethernet (TSN) backbone.

In this context, this use case defines the 6G in-vehicle wireless zone subnetwork that is utilized by some sensors and actuators located in this zone to connect wirelessly to the zone ECU that manages and controls them. The sensors and actuators that are wirelessly connected to the zone ECU are equipped with a 6G-capable wireless communication interface that replaces their former wired communication interface. Note that it would also be possible to utilize the wireless interface for high-reliability designs using redundant in-vehicle wireless and wired connections. The zone ECU includes a wireless

communication interface and AP capabilities to wirelessly communicate with the sensors and actuators of this in-vehicle wireless zone, and it maintains the wired communication interface(s) that it uses to communicate with the sensors and actuators that are not part of the 6G wireless subnetwork and with the HPCU.

Identifying which cables are replaced by wireless connections will be a critical aspect of this use case. In principle, the 6G in-vehicle zone wireless subnetwork is considered to replace cable links utilized to support demanding and critical information, which justifies the need for a 6G wireless technology. For example, this might be the case of cable links utilized to transfer (raw) sensor data generated by sensors like cameras, radars, or lidars, which are utilized in ADAS-based automotive systems. The introduction of wireless links in in-vehicle networks could also be justified by the necessary flexibility and reliability of in-vehicle networks to adapt to needs demanded by sophisticated systems like AD. Wired connections have been the traditional method for in-vehicle communication due to their stability and robustness. However, the challenge lies in adapting cabled-based networks to keep up with the evolving needs of modern vehicles. By integrating wireless connectivity into the in-vehicle network design, there's an opportunity to increase flexibility and accommodate new technologies more efficiently. Wireless connections can also be introduced for redundancy to increase the in-vehicle network reliability when combined with wired connections.

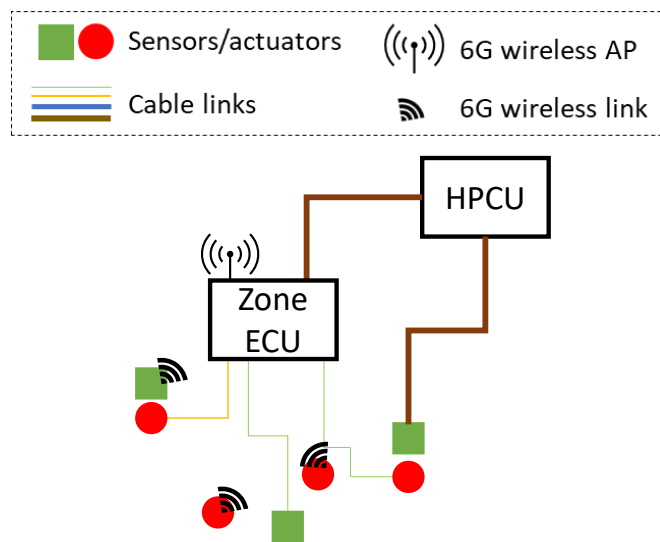

Figure 34: Wireless zone ECU

5.6.1.2 Pre-condition(s)

The 6G-SHINE reference in-vehicle E/E architecture is composed of zonal ECUs located at different zones of the vehicle. These zonal ECUs manage, connect, and control the sensors, actuators, and functions that surround them. The communication networks that connect sensors and actuators with zonal ECUs can be based on different wired technologies, such as CAN, Flex Ray, LIN, MOST, or Automotive Ethernet. The choice of technology depends on the specific requirements of the automotive system or service that

is supported by the sensors and actuators in the zone, such as bandwidth/speed, latency, reliability, and determinism.

This use case considers that some of the cable links that connect the sensors/actuators to the zone ECU are replaced by wireless connections and that the zone ECU also takes the role of an AP to manage these wireless links. The zone ECU is connected to the HPCU via an automotive Ethernet cable according to the 6G-SHINE reference in-vehicle EE architecture (see Section 5.3). The wireless connections between the sensors/actuators and the zone ECU form a 6G in-vehicle zone wireless subnetwork.

The sensors located in the zone (e.g., cameras, lidars, radars, etc.) capture data from the environment and transmit it via wired or wireless links to the zone ECU. The accuracy/precision and rate at which sensors operate (e.g., image resolution and frames captured per second in cameras, data density in the point clouds logged by lidars, etc.) depend on their specific functions and capabilities. Sensors of the same type could be synchronized and operate at the same rate. However, it is important to note that not all sensors need to operate with the same accuracy and at the same rate. Some sensors, such as cameras or lidars, may generate data at higher rates to capture a more detailed representation of the driving environment, while others, like temperature or pressure sensors, may provide data at a slower rate since they change relatively slowly. In-vehicle synchronization techniques ensure that the data is generated to be effectively utilized by the vehicle's systems for various tasks such as sensing, perception, planning, decision-making, and control.

The wireless zone ECU is responsible for the effective and timely management of the data generated in its zone in order to guarantee the service levels and the successful fulfilment of the associated in-vehicle functions or services when some of the cables have been replaced by wireless links.

Note: This operational flow focuses on the communication between sensors and actuators with the zone ECU. The case in which sensors and actuators can bypass the zone ECU to communicate directly to the HPCU is covered in the later use cases.

5.6.1.3 Operation Flow

The flow of operation events in the in-vehicle zone can be described as follows:

1. The sensors located in the in-vehicle zone generate data at a specific rate and with accuracy according to the automotive system.
2. The data is transmitted from the sensors to the zone ECU using the wired or wireless communication interface and technology of choice based on the requirements of the automotive system they support.
3. The zone ECU might perform certain processing on the received data, with the extent of the processing being dependent on the specific automotive function or service. However, most of the processing is carried out in the HPCU, following the operation of the centralized, zone-oriented E/E architecture.
4. As a result of 3, the zone ECU might perform one or a combination of the following actions:
 - a. Communicate to an actuator located in this zone the resulting action according to the requirements of the automotive system it provides support to.

- b. Forward the received (and processed) data from the sensors to the HPCU according to the requirements of the automotive system.

5.6.1.4 Deployment Scenarios

This use case is characterized by the presence of a set of subnetwork elements (SNEs) connected via and managed by higher capabilities (HCs) elements. All elements are deployed on a mobile platform (i.e. the vehicle), with their relative speed being 0 m/s. The in-vehicle zone accommodates a variable number of sensors and actuators, typically ranging from 10 to 30. It is important to note that the SNEs represent a specific subset of all the sensors and actuators in an in-vehicle zone –specifically those wirelessly linked to the zone ECU, acting as a HC device. The deployment area of a wireless zone ECU is confined to a limited space, approximately 1 m².

In-vehicle propagation conditions present an unexplored frontier. The operating frequency for the wireless connection between the SNEs and the HC is yet to be identified, considering existing trade-offs between bandwidth, directionality, propagation losses, etc. An intriguing research aspect involves exploring higher frequency ranges, such as FR2 or the sub-THz band, to support high data rate services. The strategic deployment of (passive) RIS or even non-reconfigurable intelligent surfaces could be considered to address blockage and penetration losses. In addition, a wise deployment of the SNEs and HC is also foreseen. Strategically deploying both RIS and HCs would also seek avoiding or controlling potential interference among wireless zone ECUs. The antenna elements of SNEs are expected to be much simpler than those utilized in higher capabilities elements such as HC device.

The data traffic in a wireless zone ECU scenario is primarily dominated by the transmission of uplink (raw) data from the sensors to the zone ECU. Downlink data is mostly expected from the zone ECU to the actuators. Sensors' soft/firm-ware updates could also generate downlink traffic in an in-vehicle wireless zone.

5.6.1.5 Subnetwork Architecture

The subnetwork architecture of this use case is illustrated in Figure 35, adhering to the guidelines and nomenclature outlined in the 6G-SHINE's reference subnetwork architecture described in Section 2. In this scenario, the sensors and actuators within the zone that establish wireless connections with the zone ECU are denoted as SNEs. Additionally, the Zone ECU and HPCU are labelled as LC and HC, respectively, reflecting their potential varying capabilities. Figure 35 shows the possibility that this use case results in a hierarchical or nested subnetwork when some of the SNEs within the zone connect to the LC and others do so directly to the HC.

In terms of functionalities or features, this use case envisions the LC taking on the roles of GW and RRM. The LC's GW role primarily involves managing data traffic within the zone, both among SNEs and between the SNEs and the HC. To fulfil this role efficiently, the LC needs to control and manage the radio resources of the in-vehicle subnetwork zone through its RRM functionality. Due to the centralized trend of the IVN and EE architecture (see Section 5.3), the HC also assumes the roles of GW and RRM. However,

in this case, these roles are jointly utilized alongside the SNM role to coordinate and manage the entire zone, as well as monitor the subnetwork's performance.

The deployment of the SNE, LC and HC within the vehicle's zone, along with their respective roles, determines the communication modes used for different connections. Direct communication is envisioned between the SNEs and the LC or between the SNEs and the HC, facilitating the exchange of both data and control information. The LC and HC may also utilize direct communication for exchanging data the LC has received from the SNEs and processed, as well as control information needed for subnetwork management. Additionally, indirect communication may be present in this use case to facilitate data exchange among SNEs, such as between a sensor and an actuator within the zone.

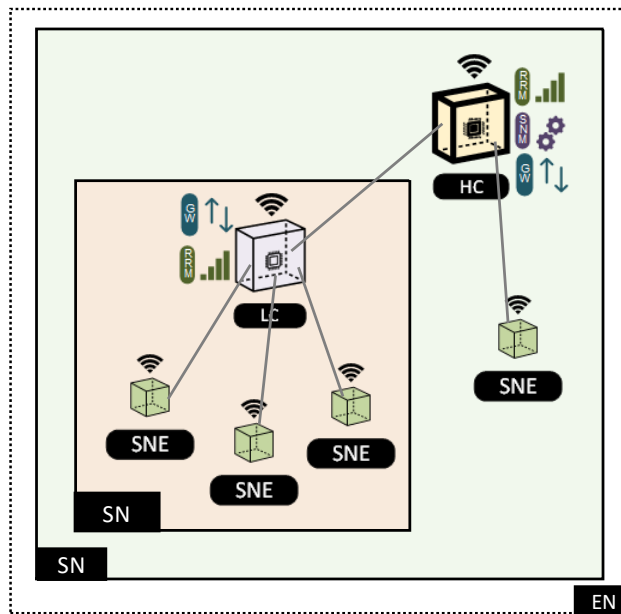

Figure 35: Subnetwork Architecture of the Wireless Zone ECU Use Case

The main functional requirements to support the subnetwork architecture of the wireless zone ECU use case are listed in Table 26.

Table 26: Functional Requirements of the Wireless Zone ECU Use Case

ID	Functional Requirement
V-1-FR-1	The system shall have a least a subnetwork element (Low Capabilities or High Capabilities) with subnetwork management capabilities (SNM).
V-1-FR-2	The system will be able to still operate when no connectivity exists from a subnetwork element with gateway capabilities to the 6G parent network.
V-1-FR-3	The system will be able to predict traffic demands to anticipate radio resource allocations.

5.6.1.6 Post-condition(s)

The zone of the 6G-SHINE reference in-vehicle E/E architecture includes sensors and actuators that are equipped with either (or both for redundancy) a wired or wireless communication interface to communicate with an AP-capable wireless zone ECU. The seamless integration and management of the wired and wireless communications between the zone ECU and the sensors/actuators, and between the zone ECU and the HPCU, guarantee the service levels and requirements of the multiple automotive systems and functions supported in the in-vehicle zone.

5.6.1.7 KPI Aspects & Potential Requirements

The defined wireless zone ECU needs to support the multiple and varying traffic characteristics of the supported automotive systems and domain functions. This might include powertrain control, chassis control, body electronics, infotainment systems, ADAS, telematics, autonomous driving, connectivity systems, and HMI, to name a few. Table 27 summarizes the main characteristics of these vehicle's domain functions as well as their associated KPIs. Wired technologies currently used to support the vehicle's domain functions reported in Table 27 include CAN, LIN, Flex Ray, MOST, Automotive Ethernet, TSN, and Radio Frequency. Table 28 shows the main features and KPIs of such wired networking technologies.

In this context, the KPI requirements for the in-vehicle wireless zone subnetworks emerge from the supported automotive systems and domain functions (Table 27) and the service levels reached with the wired networking technologies (Table 28) are to be replaced. In this specific use case, the requirements need to be restricted for the confined data and command traffic generated in a particular zone of the vehicle.

Table 27: KPIs for in-vehicle networks of the vehicle's domain functions [48]

Domain Function	Main Characteristics	KPIs for In-Vehicle Networks
Powertrain Control	Manages engine and transmission operations	Latency: <1 ms Data rate: 2Mb/s Reliability: >99.9% Determinism: Yes Control loop time: μ s
Chassis Control	Controls vehicle dynamics and handling	Latency: <1 ms Data rate: 2 Mb/s Reliability: >99.9% Determinism: Yes Control loop time: μ s/ms
Body Electronics	Controls various electrical systems in the vehicle	Latency: <2 ms Data rate: 2 Mb/s Reliability: >99% Determinism: Yes Control loop time: ms
Infotainment System	Provides entertainment, information, and connectivity	Latency: <1 ms Data rate: 1 Gb/s Reliability: >99% Determinism: Yes

		Control loop time: ms
Advanced Driver Assistance Systems (ADAS)	Enhances driver safety and assists in driving tasks	Latency: <1 ms Data rate: 100 Mb/s Reliability: >99% Determinism: Yes Control loop time: ms
Telematics	Enables remote connectivity and vehicle tracking	Latency: <500 ms Data rate: 1 Gb/s Reliability: >99% Determinism: Yes
Autonomous Driving	Enables self-driving capabilities	Latency: <1 ms Data rate: 10 Gbps Reliability: >99.9% Determinism: Yes Control loop time: ms
Human-Machine Interface (HMI)	Enables interaction between the driver and the vehicle	Latency: <100 ms Data rate: 10 Mbps Reliability:>99% uptime Determinism: Yes

Table 28: KPIs for in-vehicle wired networking technologies [47][48]

Networking Technology	Main Features	Speed [Mbps]	Determinism	Vehicle Applications/Domains
CAN/CAN FD	Robust, low-cost, widely used, multi-master protocol	≤ 1 / ≤ 6	No / Yes under circumstances	All domains Powertrain control, chassis control, body electronics, ...
LIN	Low-cost, simple, single-master protocol	< 0.02	Yes	Body and window control, lighting control, Heating Ventilation and AC control, sensors, motors, ...
Flex Ray	“High-speed”, fault-tolerant (two-channel), deterministic protocol	≤ 10	Yes	Drive-by-Wire systems, Brake-by-Wire, active suspension systems, Advanced Safety and Collision Avoidance Systems, Steer-by-Wire, Stability, powertrain
Ethernet 100BASE-TX	Fast Ethernet	100	No	Diagnostic interface
MOST	High-quality multimedia, low-latency protocol	≤ 150	Yes	Premium audio systems, infotainment systems Will be phased-out
Automotive Ethernet (10BASE-T1S, 100BASE-T1, 1000BASE-T1, 2,5/5/10GBASE-T1)	Automotive-specific Ethernet layer 1 variants/speed grades	10/100/1.000 2,5/5/10.000	No	ADAS ECUs, multimedia systems, Ethernet backbone networks, sensors, ...

TSN	IEEE Ethernet layer 2+ standards with real-time capabilities	≤ 10.000	Yes	Autonomous driving systems, connected car platforms, in-vehicle systems
-----	--	---------------	-----	---

5.6.2 Collaborative Wireless Zone ECUs: Functions across multiple in-vehicle zones

5.6.2.1 Description

This use case covers automotive systems and applications that require (or benefit from) collaboration or offloading between functions, sensors and actuators located at different zones of the considered 6G-SHINE reference in-vehicle E/E architecture (see Section 5.3). Each in-vehicle zone is characterized by the presence of a wireless zone ECU as defined in Section 5.6.1, which integrates sensors and actuators that might support automotive functions and systems of different in-vehicle domains.

This use case considers the scenario represented in Figure 36 in which two wireless zonal ECUs are interconnected via HPCU. The wireless zonal ECUs might utilize wired and wireless communications interfaces to connect with surrounding sensors and actuators, as well as an automotive Ethernet (TSN) connection to the HPCU. Some examples of the automotive functions represented by this use case include, for example, the rear-view camera application that displays the images captured by a rear-facing camera (located at the rear zone of the vehicle) onto the vehicle’s dashboard (located at the front of the vehicle), or the lane departure warning application that utilizes front-facing camera images for lane tracking/detection, and warns the driver with visual, audible and/or vibration warning when the vehicle leaves its lane without signalling it. The front-facing camera in the lane departure warning application is located at the front of the vehicle, the lane tracking/detection can be performed at the HPCU (or at the camera itself), and the warnings are sent to the driver zone.

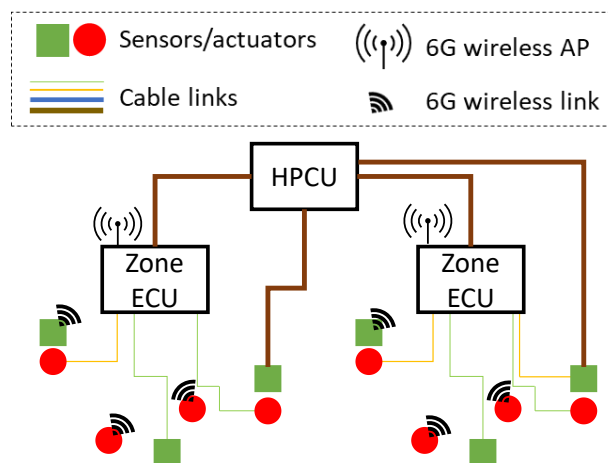

Figure 36: Collaborative wireless zone ECUs.

5.6.2.2 Pre-condition(s)

Based on the 6G-SHINE reference in-vehicle E/E architecture, each wireless zone ECU handles sensors, actuators, and functions of different domains, which are placed in the same physical area. The

communication networks that connect sensors and actuators with their wireless zone ECU are based on different wireless and wired technologies depending on the requirements of the supported automotive system or service. Wireless zonal ECUs rely on a high-speed automotive Ethernet backbone network to connect to HPCU with advanced processing capabilities.

This use case covers automotive systems and services that require for their execution the interaction and cooperation between sensors, actuators and processing units located at different in-vehicle zones. For example, the zone ECUs and the HPCU in between the two zones are responsible for managing and processing the data generated by sensors in one zone and producing the corresponding output on time for its execution in actuators located at another zone. The use case also covers scenarios in which automotive systems and services require the processing and computation offloading between in-vehicle zones to guarantee their correct execution.

5.6.2.3 Operation Flow

The flow of operations events in this use case can be described as follows:

1. The sensors located in an in-vehicle zone, or sensors located in different zones, generate (raw) data according to the automotive.
2. The data is transmitted from the sensors to their zone ECU (or directly to the HPCU) using the wired and wireless communication interface and technology of choice based on the requirements of the automotive system they support.
3. When the sensors communicate with the zone ECU, it performs some processing over the received (raw) data while strictly guaranteeing the automotive system and service requirements.
 - a. The zone ECU might identify that the execution of the functions and/or the processing of the data needs to be carried out in the HPCU. Then, the zone ECU forwards the received data to the HPCU.
4. The received (and/or processed) data from the sensors at the HPCU (directly or via the zone ECU) is processed or combined/fused.
5. The HPCU sends the post-processing feedback/command/action to the intended actuator managed by a zone ECU located at another zone.

5.6.2.4 Deployment Scenarios

The deployment scenario for the collaborative wireless Zone ECU shares similar considerations with the one described in the wireless Zone ECU use case. The primary difference arises from the density of wireless Zone ECUs present in the collaborative wireless Zone ECU. The number of wireless Zone ECUs in a vehicle is determined by the number of zones in the EE architecture, expected to be in the range from 4 to 8.

A key aspect for the proper operation of the different wireless Zone ECUs will be the deployment of the Lower Capabilities (LC) and Higher Capabilities (HC) elements to support wireless transmissions from/to the sensors and actuators, as well as their connections. The harsh operating in-vehicle conditions may require the utilization of a wired backbone to interconnect LC and HC among them. The strategic

deployment of (passive) RIS could also be of interest to improve the channel conditions between these elements.

5.6.2.5 Subnetwork Architecture

The subnetwork architecture of this use case, as depicted in Figure 37, is an extension of the subnetwork architecture presented in Figure 35 for the wireless zone ECU use case. It is tailored to accommodate the collaborative wireless zone ECU scenario specific to this use case. Similar to the wireless zone ECU use case, Figure 37 utilizes the terms SNE, LC and HC to denote sensors/actuators, zone ECU and HPCU, respectively. Likewise, these in-vehicle elements maintain the same categories of functionalities or features across both use cases. However, the collaborative scenario envisioned in this use case involves SNEs located in different in-vehicle zones, necessitating higher GW, RRM and SNM capabilities at the HC. This enables the interconnection, management, orchestration, and control of various in-vehicle subnetworks.

In terms of communication modes, this use case introduces additional requirements for communicating between SNEs in different subnetworks via the HC (and potentially the LC if the SNEs are connected to it). The collaborative Wireless Zone ECU may also involve indirect communication between LCs via the HC, particularly for the exchange of control information.

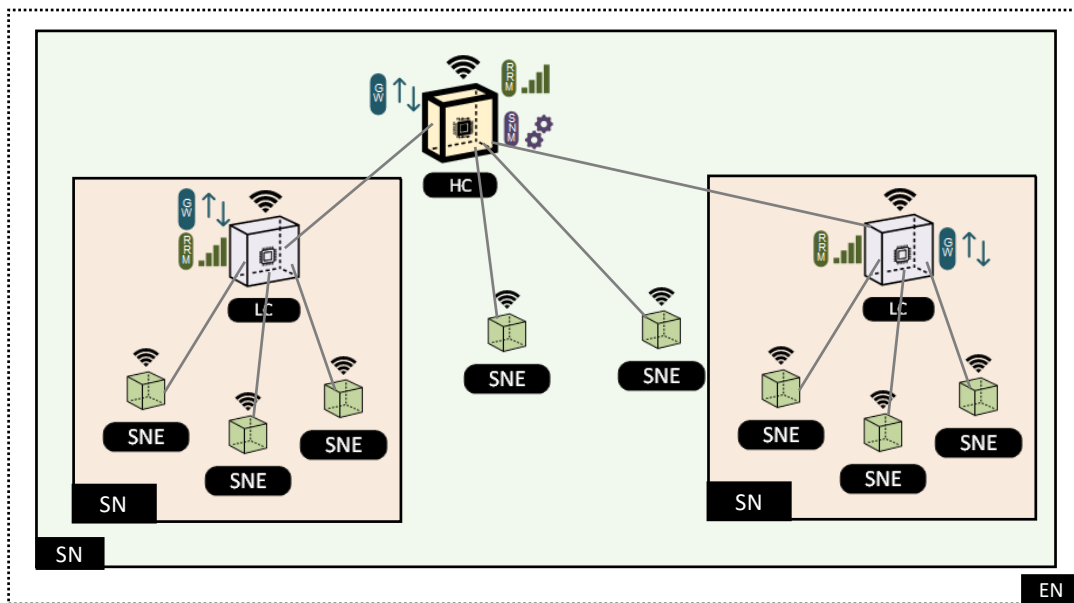

Figure 37: Subnetwork Architecture of the Collaborative Wireless Zone ECUs Use Case

The main functional requirements to support the subnetwork architecture of the wireless zone ECU use case are listed in Table 29.

Table 29: Functional Requirements of the Collaborative Wireless Zone ECUs Use Case

ID	Functional Requirement
----	------------------------

V-2-FR-1	The system shall have at least a subnetwork element (Low Capabilities or High Capabilities) with subnetwork management capabilities (SNM).
V-2-FR-2	The system will be able to still operate when no connectivity exists from a subnetwork element with gateway capabilities to the 6G parent network.
V-2-FR-3	The system will be able to predict traffic demands to anticipate radio resource allocations.
V-2-FR-4	The system shall include at least a subnetwork element (LC or HC) with gateway capabilities to inter-connect different subnetworks.
V-2-FR-5	The system will support a mechanism for a subnetwork element to be member of more than one subnetwork.

5.6.2.6 Post-condition(s)

The 6G-SHINE reference in-vehicle E/E architecture includes zonal wireless ECUs (as defined in Section 5.3) that communicate between them through a HPCU using an automotive Ethernet backbone connection. The wireless zone ECUs and HPCU seamlessly manage and control the traffic generated by the sensors connected through wireless or wired connections. In this use case, the automotive systems are supported by zone ECUs and HPCU through the collaboration and/or offloading between sensors, actuator, and/or functions located in different in-vehicle zones. The collaboration and offloading between the in-vehicle zones guarantee the service levels of the supported automotive systems.

5.6.2.7 KPI Aspects & Potential Requirements

This use case's KPI requirements also emerge from the automotive functions domain (Table 27) and the cable-based networking technologies (Table 28) that have been utilized traditionally to support them. In this case, the requirements to be considered are those related to automotive functions that necessitate coordination between sensors and actuators situated in various zones of the vehicle.

5.6.3 Inter-subnetwork Coordination: Collaboration between subnetworks in intra/inter-vehicle communications

5.6.3.1 Description

In a fully connected vehicle scenario according to the 6G-SHINE reference in-vehicle E/E architecture, different components communicate with each other through a wireless link. In this environment, the allocation of network resources emerges as a critical factor. This importance is amplified by the demanding nature of automotive application requirements among varying components and the inherent scarcity of network resources. The scenario becomes further challenging when multiple vehicles come into proximity with each other, such as on a busy road. Interference among the wireless subnetworks across these vehicles can potentially degrade the performance of the communication systems within each vehicle.

Consequently, two levels of Radio Resource Management (RRM) become essential:

1. Intra-vehicular RRM:

This optimizes the distribution of network resources among different components of the E/E architecture within a vehicle, ensuring smooth and uninterrupted communication. It also involves managing resources, for example, between different zones or components within the vehicle, as illustrated in Figure 38;

2. Inter-vehicular RRM:

This manages potential interference between adjacent vehicles to prevent any performance degradation. This involves careful resource allocation to mitigate the risk of cross-vehicle interference, which becomes especially important when vehicles are close to each other, as illustrated in Figure 39.

This use case highlights the need for a sophisticated RRM system that can handle both these levels of management efficiently, ensuring optimal performance of the wireless subnetworks in an automotive E/E architecture.

We should note that this use case could be applied concurrently with the other use cases presented for in-vehicle wireless subnetworks.

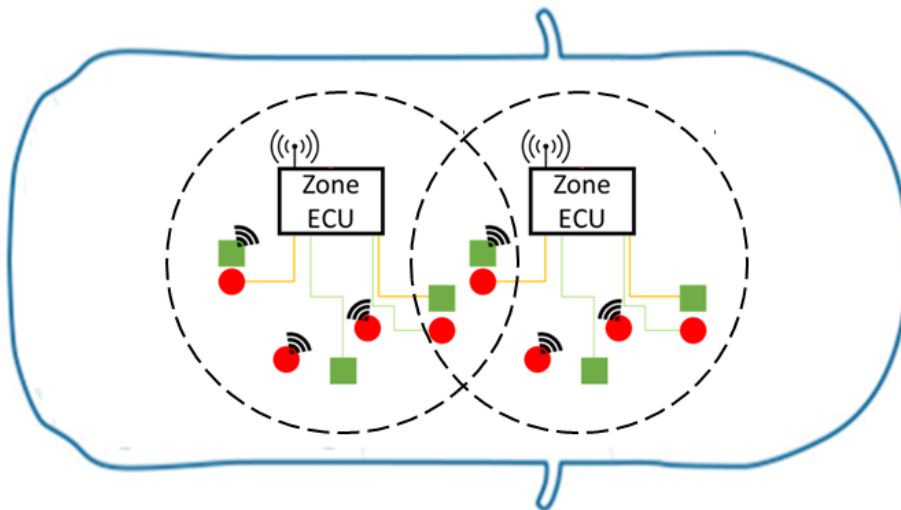

Figure 38: Intra-vehicular RRM within the 6G-SHINE reference E/E Architecture.

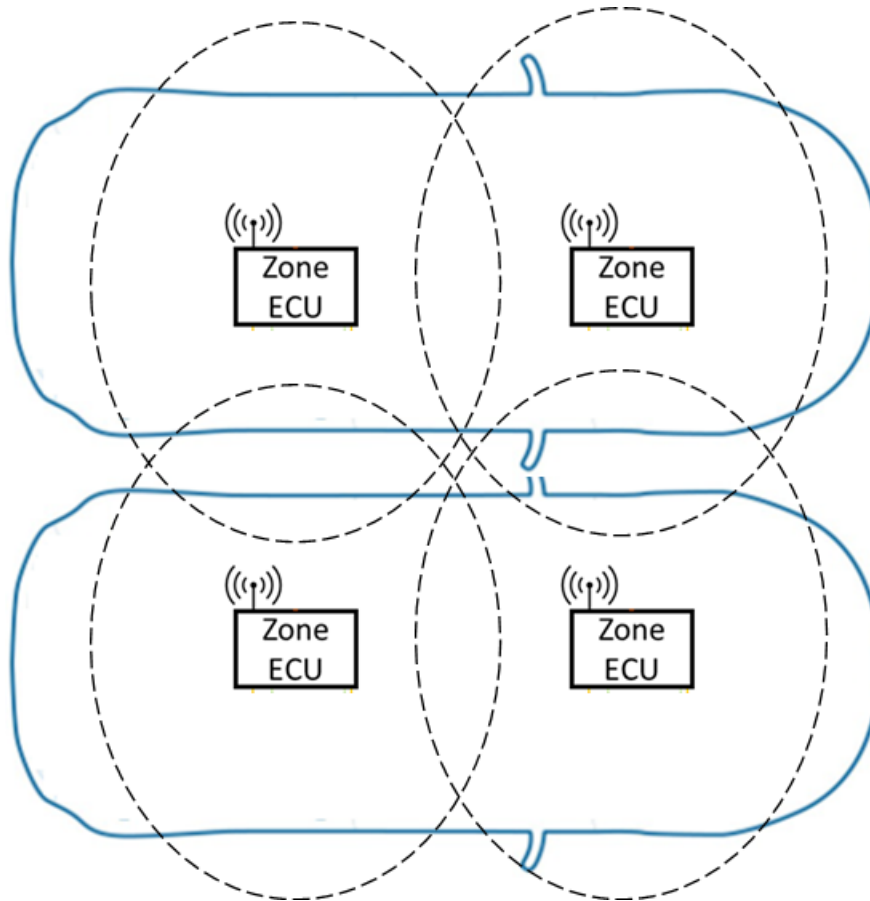

Figure 39: Inter-vehicular RRM between adjacent vehicles.

5.6.3.2 Pre-condition(s)

In this setup, each zone ECU manages sensors, actuators, and other functions within its specific domain, located in the same physical area. The communication networks connecting these sensors and actuators to their respective zone ECUs are based on wired/wireless technology. Each network has a unique set of requirements contingent on the particular automotive system or service they support.

These zone ECUs rely on a high-speed automotive backbone network for connection to HPCU, which provides advanced processing capabilities. This connection could be either wireless or Ethernet-based (or a combination of both for redundancy, see Section 5.4).

Like the ‘Collaborative Wireless Zone ECUs’ use case (see Section 5.6.2), this use case is focused on automotive systems and services that necessitate collaboration and interaction between sensors and actuators located in different in-vehicle zones. However, given the limited wireless network resources available for communication, this use case focuses on the use of these resources which must be meticulously managed.

The zone ECUs and the HPCU positioned between two zones handle the management and processing of data generated by sensors in one zone, producing timely output for actuation in another zone

(‘Collaborative Wireless Zone ECUs’ use case in Section 5.6.1). Proper wireless resource management is crucial to ensure that the communication requirements of each entity are successfully met during the vehicle's operation (this use case).

Furthermore, this use case also considers scenarios where adjacent vehicles can cause mutual interference. In such instances, a coordination protocol (either centralized through a 6G parent network or distributed) is necessary to prevent performance degradation. This makes it crucial to develop efficient mechanisms for managing both intra-vehicle and inter-vehicle wireless resources, ensuring optimal performance of the E/E architecture in both single-vehicle and multi-vehicle scenarios.

5.6.3.3 Operation Flow

The sequence of events in this use case is as follows:

1. Sensors within a particular in-vehicle zone generate data, following the specifications of the automotive system they support.
2. This data is wirelessly transmitted from the sensors to the corresponding zone ECU via a wireless communication interface. The choice of wireless resource parameters (such as time/frequency resources, MCS, PMI, TM, etc.) depends on the requirements of the supported automotive system and the need to mitigate potential interference with other entities within the E/E architecture or nearby vehicles.
3. The zone ECU receives and processes the sensor data, generating an actuation command. This command can either be executed locally or sent to another zone ECU for further processing and/or execution. The latter is facilitated via the HPCU using another wireless link.
4. If the command is sent to another zone ECU, the choice of wireless resource parameters to be utilized again depends on the requirements of the application and the need to mitigate potential interference with other entities within the E/E architecture or nearby devices.
5. In scenarios where a nearby vehicle is present, interference management becomes crucial to prevent performance degradation of the wireless connections between the vehicles. This entails implementing a strategy (either centralized or distributed) to manage and minimize interference, thereby ensuring a smooth operation of the wireless links within and between vehicles.

5.6.3.4 Deployment Scenarios

The deployment within and across E/E architecture zones follows the scenarios of the first two vehicular use cases. Now, the need for coordination of multiple such subnetwork within and beyond a vehicle adds another level of complexity to the overall architecture. For intra-vehicular RRM, the subnetworks are still stationary, while the elements in the inter-vehicular RRM case moving relatively to each other.

We can assume up to four subnetworks to be coordinated within a vehicle, corresponding to four zones in the E/E architecture. For an intersection scenario, the number of subnetworks depends on the number of involved vehicles and hence on the complexity of the traffic scenario and the distance between

vehicles, at which radio resource management becomes important. In this regard, five vehicles employing wireless subnetworks and a confined area of an intersection is reasonable.

5.6.3.5 Subnetwork Architecture

Figure 40 shows the subnetwork architecture for the Inter-Subnetwork Coordination use case, which is an extension of the architecture of the second vehicular use case towards involving at least two vehicles. The architecture shows two entities, i.e., vehicles that are comprised of multiple zones, again represented as subnetworks. In addition, each vehicle has a higher-level subnetwork, into which the zone subnetworks are integrated in a hierarchical manner. Within them, HCs, e.g., the HPCUs/CCUs, can act as gateways towards the 6G parent network and can also communicate with each other in an ad-hoc manner. This enables direct communication and hence coordination of subnetworks between the vehicles, e.g., to perform radio resource management in a hybrid fashion, while the 6G BS also employs at least a part of the radio resource management. Other subnetwork management functionalities (SNM role) are distributed among the 6G network and the vehicles' HCs.

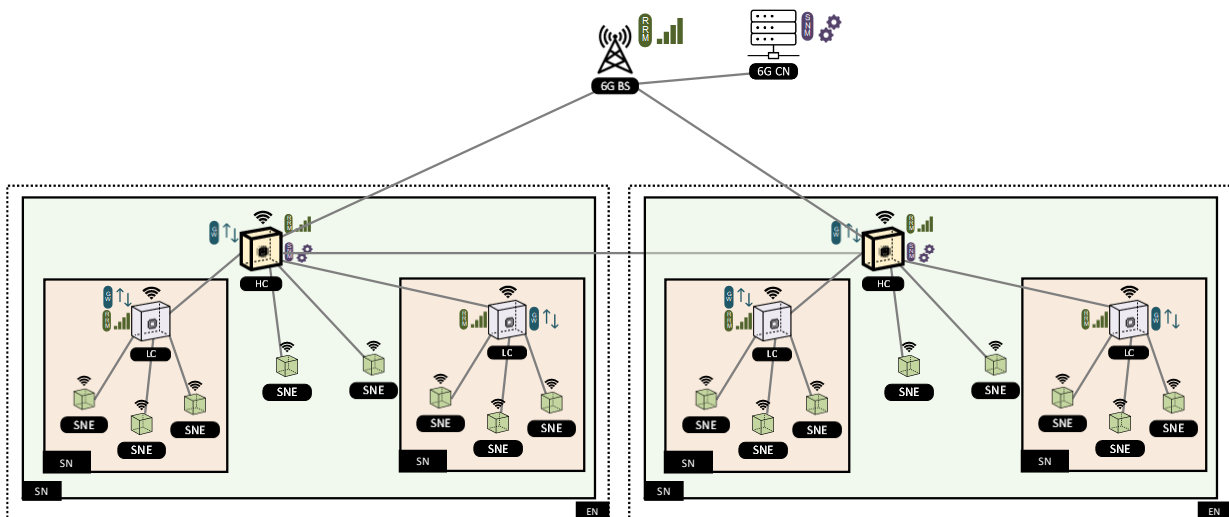

Figure 40: Subnetwork Architecture of the Inter-subnetwork Coordination Use Case

The main functional requirements to support the subnetwork architecture of the Inter-subnetwork Coordination use case are listed in Table 30.

Table 30: Functional Requirements of the Inter-subnetwork Coordination Use Case

ID	Functional Requirement
V-3-FR-1	The system shall have at least a subnetwork element (Low Capabilities or High Capabilities) with subnetwork management capabilities (SNM).
V-3-FR-2	The system will be able to still operate when no connectivity exists from a subnetwork element with gateway capabilities to the 6G parent network.
V-3-FR-3	The system will be able to predict traffic demands to anticipate radio resource allocations.
V-3-FR-4	The system shall include at least a subnetwork element (LC or HC) with gateway capabilities to inter-connect different subnetworks.

V-3-FR-5	The system will support a mechanism for a subnetwork element to be member of more than one subnetwork.
V-3-FR-6	The system shall enable direct communication between HC (HPCU) of different vehicles in an ad-hoc manner.
V-3-FR-7	The system shall enable sidelink between HCs to enable distributed RRM if central RRM in 6G parent network is not available.
V-3-FR-8	The system shall enable the interaction of RRM in the HCs and the centralized RRM for a hybrid setup.

5.6.3.6 Post-condition(s)

Upon successful execution of this use case, the following conditions should hold:

- The zone ECUs and the HPCU operate seamlessly and reliably over wireless connections. Their coordination is critical in managing and processing data within the vehicle's E/E architecture.
- Any potential intra- and inter-vehicle interference is effectively managed, preventing any performance degradation within the E/E architecture. Efficient RRM ensures that wireless resources are optimally allocated, considering the needs of the system and the potential interference from within the vehicle or from nearby vehicles.
- It is assumed that the automotive systems supported by the zone ECUs and HPCU necessitate collaboration among sensors, actuators, and/or functions located in different in-vehicle zones. These collaborations, facilitated by efficient wireless communication and resource management, ensure the service levels of the supported automotive systems are met.
- The integrity of the wireless communication within and between vehicles is maintained, preserving the effectiveness and safety of the overall E/E architecture, even in complex multi-vehicle environments.

5.6.3.7 KPI Aspects & Potential Requirements

Our vision aligns with the KPIs outlined in the Wireless Zone ECU use case (see Section 5.6.1.7). The transition from a traditional networking technology to wireless links must meet specific criteria in terms of speed, distance, and determinism. For achieving this transition, the wireless links must maintain the performance of their wired predecessors. They must offer high-speed connections that support the required distance between components, and ensure deterministic responses, a critical aspect for safety-related automotive applications. Consequently, the implementation of strategic RRM will be key to efficiently managing potential interferences within the wireless network, ensuring optimal performance and system reliability.

5.6.4 Virtual ECU: In-vehicle sensor data and functions processing at the 6G network edge

5.6.4.1 Description

This use case focuses on integrating the in-vehicle network with the 6G parent network, following the 6G 'network of networks' paradigm. The goal is to seamlessly extend the in-vehicle embedded computing capabilities to the edge/cloud. The connection from the in-vehicle network to the edge/cloud

is exploited in this use case to enable opportunistic offload and vehicle-network-cloud cooperation to support advanced in-vehicle automotive functionalities critical for AD and the continuous evolution and advancement of vehicles. This way the edge/cloud would act as a virtual ECU (or HPCU) by elastically extending the computing and processing capabilities of the vehicle using the 6G network. This includes, for instance, the possibility to opportunistically offload to the edge or cloud the processing of the sensor data generated in an area supported by the wireless zone ECU (see Section 5.6.1), and some demanding functions like the machine learning inference. This use case also enables the possibility of data collaboration and machine learning operation based on the data from multiple vehicles.

The integration between the in-vehicle network and the 6G network will also facilitate over-the-air updates (OTA), whose demands will significantly increase with the softwarization of vehicles. It will also provide a framework for reliable management of interference and radio resources between in-vehicle subnetworks supported by the network infrastructure, including the possibility of performing dynamic spectrum sharing between a 6G parent network and in-vehicle subnetworks.

This use case utilizes the high capabilities of the in-vehicle HPCU (and CCU) to act as the bridge between the in-vehicle network and the 6G parent network (see Figure 41). In this use case, we will focus on ensuring that offloading processing and functions from the in-vehicle network to the 6G network do not affect service provisioning (including guaranteed bounded latencies and determinism), even if there are changes in the quality-of-service levels within the 6G parent network.

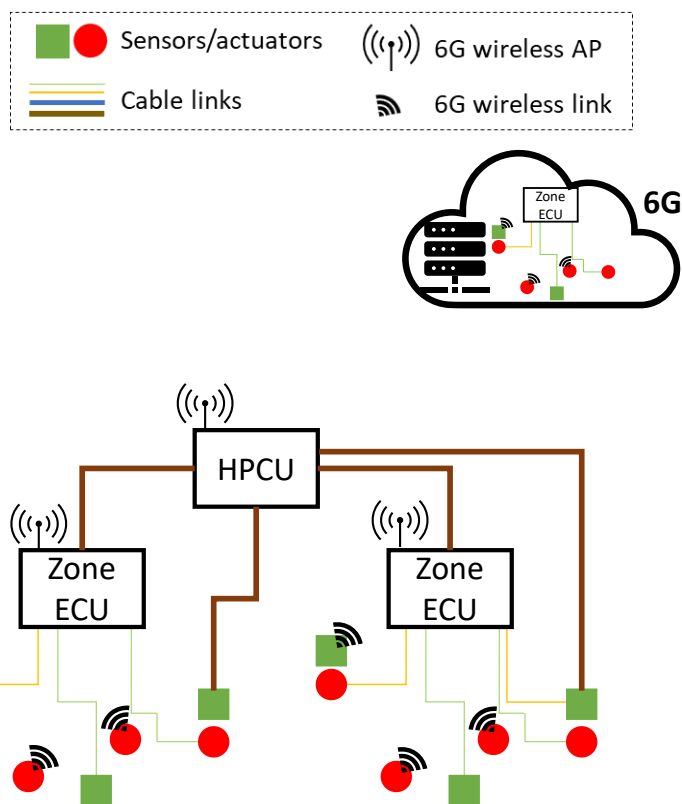

Figure 41: Integration of the 6G in-vehicle network with the 6G parent network.

5.6.4.2 Pre-condition(s)

The 6G-SHINE reference centralized, zone-oriented E/E architecture is network-access oriented. The network access is gained through a CCU –implemented and located closely to the HPCU (and thereby efficiently connected to it)– that acts as a gateway between the in-vehicle network and the 6G parent network. This use case extends the integration with the 6G network to also include the in-vehicle 6G subnetworks. The HPCU performs most of the demanding data and processing functions, and it can proactively or reactively decide to offload (part of) such processing to a computing platform located in the 6G network’s cloud/edge.

5.6.4.3 Operation Flow

The flow of operations enabled by the integration between the in-vehicle subnetworks and the 6G parent network include:

1. Sensors located in an in-vehicle zone generate data according to the automotive system they provide support to.
2. The data is transmitted from the sensors to the zone ECU using the wired or wireless communication interface and technology of choice based on the requirements of the automotive system they support.
3. The zone ECU might perform some processing of the data or forward it to the HPCU.
4. The HPCU decides to offload partially or completely the data processing to the edge or cloud computing facilities.
5. The data processing is completed on time and the resulting action, if needed, is implemented by the in-vehicle actuator according to the implemented automotive system.

The operation flow could also be extended for the offloading of critical in-vehicle functions (e.g., machine learning inference) to be implemented at the edge.

5.6.4.4 Deployment Scenarios

The in-vehicle deployment scenario of the virtual ECU use case shares the same considerations as the previous in-vehicle subnetwork use cases. The extension of this use case focuses on integrating in-vehicle subnetworks with the 6G parent network. To achieve this, the setup at the Higher Capabilities (HC) subnetwork element needs to be extended with the appropriate equipment facilitating such integration.

This includes, for instance, the antenna set mounted on the vehicle’s roof to enhance visibility with the base station or gNB of the 6G parent network. The operational frequency for the link between the vehicle and the 6G network’s gNB needs investigation. The Frequency Range 3 (FR3) band, spanning from 7 GHz to 24 GHz, presents a promising option for this link due to its larger spectrum and higher robustness to blockage compared to lower and higher frequency bands.

5.6.4.5 Subnetwork Architecture

The subnetwork architecture represented in Figure 42 is designed to support the operation of the Virtual ECU on the (edge) cloud. Nomenclature-wise, SNE, LC and HC also refer in this case to the

sensors/actuators, Zone ECU and HPCU, respectively. The GW, RRM and SNM functionalities or features need to be extended in this use case to consider the integration of the vehicle/entity with the 6G parent network. In addition, this use case places OFF capabilities to the HC and CompN to perform the coordinated offloading of the in-vehicle functions to the edge cloud.

The Integration to the 6G parent network also opens new communication modes possibilities in this use case that add to the ones included in the previous use cases. In particular, this use case considers direct communication between the HC and the 6G network for the exchange of both data and control information and to enable the offloading of processing tasks from the vehicle to the edge cloud.

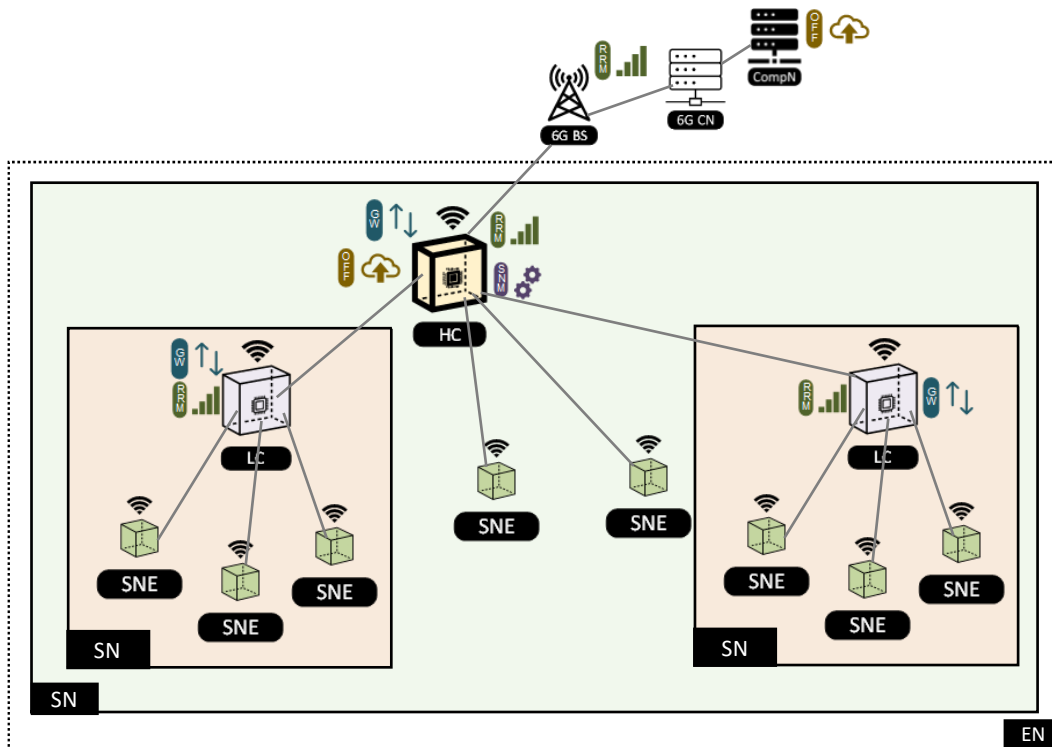

Figure 42: Subnetwork Architecture of the Virtual ECU Use Case

The main functional requirements to support the subnetwork architecture of the Inter-subnetwork Coordination use case are listed in Table 31.

Table 31: Functional Requirements of the Virtual ECU Use Case

ID	Functional Requirement
V-4-FR-1	The system shall have a least a subnetwork element (Low Capabilities or High Capabilities) with subnetwork management capabilities (SNM).
V-4-FR-2	The system will be able to still operate when no connectivity exists from a subnetwork element with gateway capabilities to the 6G parent network.
V-4-FR-3	The system will be able to predict traffic demands to anticipate radio resource allocations.

V-4-FR-4	The system shall include at least a subnetwork element (LC or HC) with gateway capabilities to inter-connect different subnetworks.
V-4-FR-5	The system will support a mechanism for a subnetwork element to be member of more than one subnetwork.
V-4-FR-6	The system shall include at least a subnetwork element (LC or HC) with gateway capabilities to connect to the 6G parent network.
V-4-FR-7	The system will support mechanism(s) to identify an in-X subnetwork and a subnetwork element with gateway capabilities.
V-4-FR-8	The subnetwork system shall be able to connect with a parent network when available.
V-4-FR-9	The subnetwork system shall be able to discover compute resources in the parent network to support application and computing offloading.

5.6.4.6 Post-condition(s)

The 6G-SHINE reference centralized, zone-oriented E/E architecture seamlessly integrates the in-vehicle 6G subnetworks with the 6G parent network. This enables opportunistic and on-demand off-boarding sensor data processing and functions while satisfying the service levels, including deterministic ones, of the supported automotive system.

5.6.4.7 KPI Aspects & Potential Requirements

This use case's requirements still emerge from the automotive functions and domains reported in Table 27 which are currently supported using the wired networking technologies shown in Table 28. However, this use case seeks fulfilling the requirements of these automotive functions and domains despite part of the processing and/or computation, which is traditionally carried out in the vehicle can be offloaded to the edge or cloud. The use case also considers automotive functions that will arise from the integration of the in-vehicle subnetworks within the 6G 'network of networks' (e.g., OTA, digital twinning), and whose requirements will need to be supported without compromising the service provisioning in the connectivity continuum subnetwork-edge-cloud.

5.7 IN-VEHICLE NETWORK TRAFFIC CHARACTERISTICS

5.7.1 Connected and Automated Mobility (CAM) Research Platform

UMH has developed an advanced CAM simulation platform (Figure 43) for connected and autonomous driving research that integrates realistic sensing and autonomous driving capabilities. The CAM simulation platform has been implemented using and extending the open-source software CARLA (<https://carla.org/>) and AUTOWARE (<https://autoware.org/>), two widely accepted and employed tools in the CAM research community. The CAM platform seamlessly combines a realistic 3D modelling of the driving environment and the vehicle sensing capabilities through CARLA, and a fully functional and

ready-to-use autonomous driving software stack to control the vehicles driving based on the perceived data using AUTOWARE.

In detail, CARLA is a 3D simulator built on Unreal Engine 4 (UE4) for autonomous driving research that has been developed to support development, training, and validation of autonomous driving systems and algorithms. CARLA embeds a high-fidelity 3D real-world representation and simulation of the driving environment that includes different types of vehicles (including cars, trucks, and motorcycles), pedestrians, buildings, light and weather conditions. CARLA also implements a complete suite of automated driving sensors (e.g., cameras, radars, lidars, Inertial Measurement Unit (IMU), Global Navigation Satellite System (GNSS)) that can be flexibly configured by the user on each simulated vehicle. On the other hand, AUTOWARE is an open-source autonomous driving software stack that implements all the sensing, perception, localization, planning, and control functionalities required for autonomous driving. AUTOWARE is built on Robot Operating System (ROS) and allows real-world deployment of autonomous driving in a broad range of vehicles and applications. As of today, AUTOWARE has already been deployed and tested on real-world Automated Valet Parking (AVP) applications, public road robotaxi, shuttle, and bus implementations, autonomous warehouse logistics operation, and autonomous racing.

The integration between CARLA and Autoware is achieved through the Zenoh bridge software tool (Figure 43). Zenoh (<https://zenoh.io/>) is a scalable low-latency high-throughput routing protocol that allows the connection of multiple AUTOWARE instances (i.e., of multiple autonomous vehicles) with the same CARLA simulation. This is a distinctive feature of the Zenoh-based bridge with respect to other existing bridge solutions. The bridge extracts from CARLA the information captured by the vehicle sensors (e.g., camera images or lidar point-clouds), as well as GNSS or IMU information, performs the necessary transformations and sends the processed information to the sensing ROS module of the corresponding AUTOWARE instance. Then, AUTOWARE exploits the received information to run the autonomous driving modules (e.g., perception and planning) and control the vehicle. The control commands generated by Autoware (e.g., steering angle, braking, and acceleration) flow through the Zenoh-based bridge in the opposite direction and reach CARLA, where the autonomous vehicle position and dynamics are updated. The bridge also guarantees that CARLA and AUTOWARE run synchronously.

The team has notably expanded the integrated CARLA-Zenoh bridge-Autoware platform to accommodate advanced autonomous driving levels, introducing enhanced sensing capabilities both in terms of the types of sensors supported and their quantity within the vehicles.

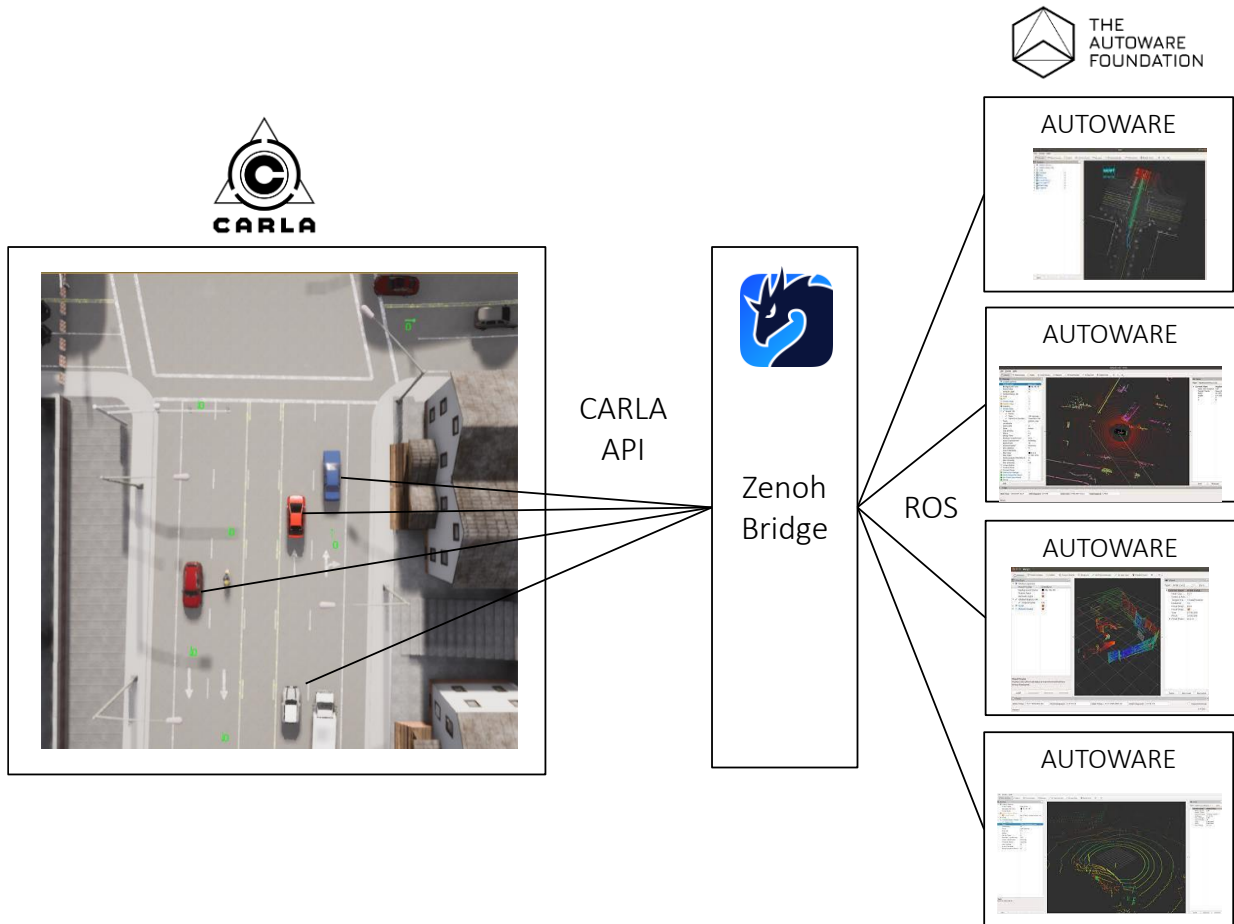

Figure 43: CAM research platform for IVN traffic characterization.

The CAM platform can be installed in a single computer or in two different computers. In the latter case, running CARLA and AUTOWARE on two separate computers allows to split the simulation workload in terms of memory, CPU, and GPU usage. In both cases, the Zenoh-based bridge is used to interface CARLA and AUTOWARE. In the single computer case, CARLA and AUTOWARE communicate through the Zenoh bridge over the loopback interface whereas, in the two-computers case, the two computers running CARLA and AUTOWARE are connected over a dedicated LAN connection. The two-computers configuration with a single AUTOWARE instance, i.e., one simulated autonomous vehicle, employed in the 6G-SHINE project is shown in Figure 44. The hardware setup consists of two high-end PCs (i9-9980X 18 cores 4,4Ghz, 64 Gb RAM, SSD 960 Gb, 2 NVIDIA Quadro P4000 GPUs) connected through a 10Gb Ethernet switch.

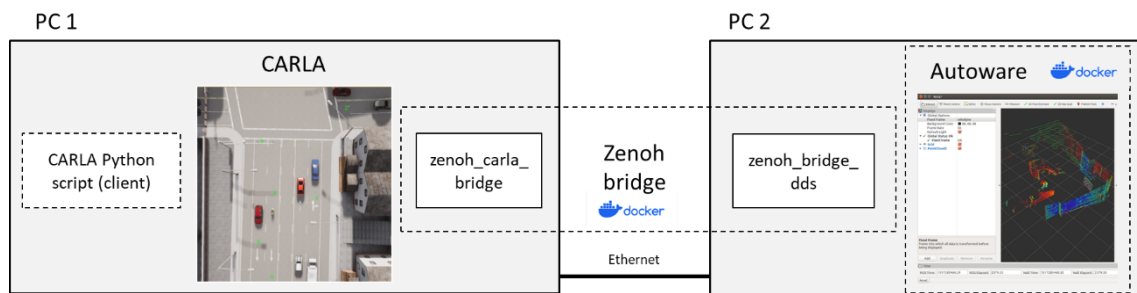

Figure 44: CAM research platform setup with a single AUTOWARE instance.

5.7.2 Sensor Deployment and Characteristics

UMH has significantly expanded the integrated CARLA-Zenoh-AUTOWARE CAM simulation platform to introduce enhanced sensing capabilities, extending the types of supported sensors, and increasing the maximum number of sensors supported by each autonomous vehicle. The implementation of enhanced sensing capabilities allows the simulation of more realistic sensor deployments and of advanced autonomous driving levels, therefore representing a key contribution in the framework of the 6G-SHINE project for research on advanced In-Vehicle Networks (IVN) and Electrical/Electronic (E/E) architectures, as well as in-vehicle computing configurations.

The flexibility offered by CARLA allows the configuration and positioning of an arbitrary number of sensors on the simulated autonomous vehicle. The sensors deployment currently utilized in the 6G-SHINE project replicates a realistic Level 3 (L3) autonomous driving deployment and is illustrated in Figure 45. The sensors characteristics - and the corresponding CARLA parameters - are reported below:

- Lidar
 - Sampling period (*sensor_tick*): 100 ms
 - Range (*range*): 100 m
 - Horizontal field of view (*horizontal_fov*): 360°
 - Upper/lower field of view (*upper_fov/lower_fov*): 10°/-30°
 - Rotation frequency (*rotation_frequency*): 10 Hz
- RGB camera
 - Sampling period (*sensor_tick*): 50 ms
 - Field of view (*fov*): 90°
 - Image width (*image_size_x*): 2560 pixels
 - Image height (*image_size_y*): 1440 pixels
- Radar
 - Sampling period (*sensor_tick*): 50 ms
 - Range (*range*): 100 m
 - Horizontal field of view (*horizontal_fov*): 30°
 - Vertical field of view (*vertical_fov*): 30°
- IMU
 - Sampling period (*sensor_tick*): 50 ms
- GNSS
 - Sampling period (*sensor_tick*): 50 ms

In AUTOWARE, the identification of objects (e.g., obstacles, pedestrians, vehicles) from raw sensor data is implemented in the perception module through GPU-hungry AI-based object detection algorithms. Approximately, object detection consumes 800 MB-1 GB of GPU memory for each sensor (RGB camera, lidar, and radar), therefore limiting the maximum number of sensors that can be mounted on the autonomous vehicle. To overcome these hardware limitations, UMH has equipped its CAM simulation platform with multiple GPUs to support the required number of on-board sensors and has implemented new functionalities in AUTOWARE to distribute and balance the GPUs workload.

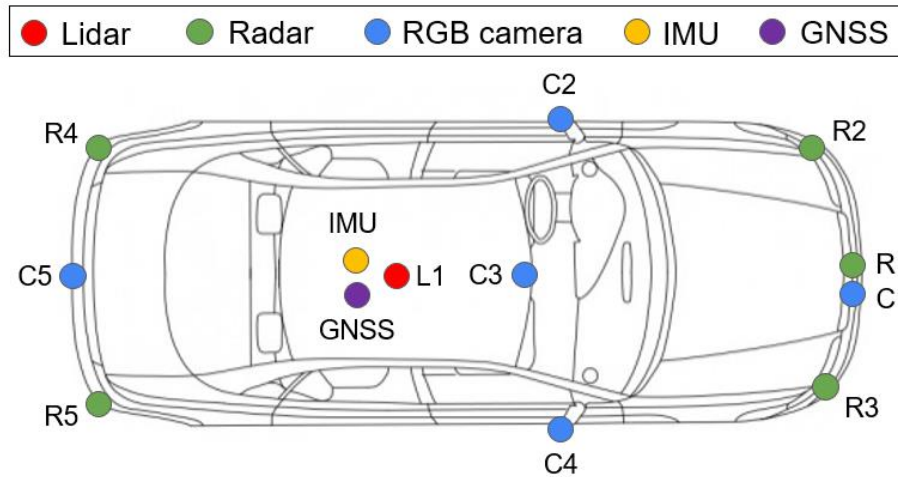

Figure 45: Sensor deployment for the L3 autonomous vehicle.

5.7.3 Message Logging

A relevant contribution of the 6G-SHINE project consists in the characterization of in-vehicle traffic. This is accomplished by mapping between the IVN elements (e.g., sensors, actuators, and zone ECUs,) and the in-vehicle messages generated by the IVN elements, which guarantees the reproduction of the exchanged data in advanced IVN and E/E architectures. In this regard, the UMH contributions are two-fold: first, the UMH team has developed and added logging methods to record the ROS messages exchanged between the different AUTOWARE nodes and to extract their distinctive features, e.g., size, timestamp, etc. Second, the UMH team identified the most relevant AUTOWARE ROS topics and corresponding messages that impact the driving of the autonomous vehicle. AUTOWARE's main functionalities, their interrelations, and the most relevant topics (messages) selected for the characterization of in-vehicle traffic are illustrated in Figure 46.

Figure 46 also sheds light on the interrelations between the different AUTOWARE modules, providing a schematic overview of the message flow: raw sensor data is generated inside the sensing module (purple container) and passed to the perception module (green container), where information about detected objects (pedestrians, vehicles, obstacles) is extracted from raw RGB images and lidar or radar pointclouds. Then, perception data is forwarded to the planning module (yellow container) and combined with information about the position and kinematic state of vehicle (generated by the localization module) to compute the optimal driving trajectory. The planned trajectory is passed to the control module (orange container) which computes the actual commands (e.g., steering angle, acceleration) required to drive the vehicle along the planned trajectory, and eventually sends the driving commands to the vehicle interface module (blue container) for actuation.

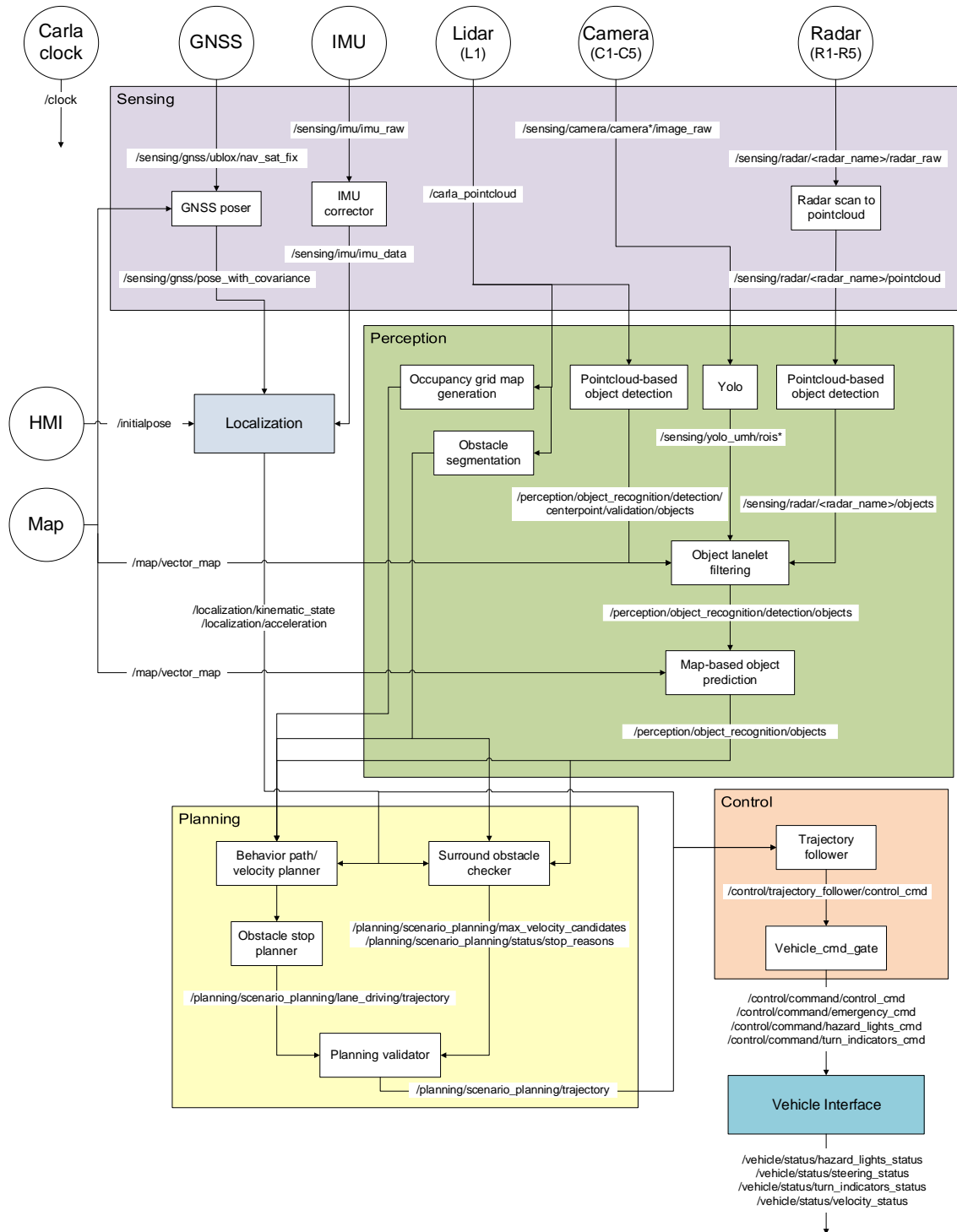

Figure 46: AUTOWARE main functionalities and relevant ROS topics.

5.7.4 Driving scenarios

Another important feature offered by CARLA consists in the availability of 12 different simulation scenarios (Town01-Town12) that cover a broad range of driving environments: from urban scenarios

with residential and commercial buildings, to rural environments and multi-lane highways. In addition, CARLA allows the custom configuration of the simulated vehicles' number and starting position, therefore allowing the simulation of different vehicular densities by changing the number of vehicles that surround the ego-vehicle, i.e., the autonomous vehicle connected to AUTOWARE.

The possibility to simulate different driving scenarios and vehicular densities is particularly relevant for the 6G-SHINE project, as it allows an exhaustive characterization of in-vehicle traffic considering a complete set of driving conditions.

In the 6G-SHINE project, we consider the three different driving scenarios shown in Figure 47:

- 1) A highway scenario where all vehicles travel in the same direction.
- 2) A two-way urban scenario where surrounding vehicles travel in both the same and in the opposite direction of the ego-vehicle.
- 3) An urban scenario where the ego-vehicle crosses an intersection.



Figure 47: Driving scenarios: left: highway with vehicles driving in the same direction; center: urban with vehicles driving in opposite directions; right: intersection scenario.

5.7.5 Results

We present in this section the results of an accurate characterization of in-vehicle network traffic carried out utilizing the CAM simulation platform. For the simulations, the ego vehicle mounts the sensors described in Section 5.7.2, which correspond to a L3 autonomous driving sensor deployment. The simulations are performed for the three driving scenarios reported in Section 5.7.4 and simulating three different vehicular densities to represent increasingly congested driving conditions: empty scenario - only the ego vehicle drives in the scenario; used as benchmark-, low and medium densities. Without loss of generality, we use for the analysis reported in this section the urban scenario with medium density as a reference unless otherwise stated. The traces collected during the driving tests, together with their detailed analysis and traffic modelling/characterization, will be released as part of the 6G-SHINE data management plan.

Figure 48 reports the message size (the box plot reports the median value with red line, the 25% and 75% percentiles with blue box, and the minimum and maximum values with black whiskers) and average

data rate that characterize the raw and processed data of each sensor type mounted on the vehicle. This figure shows that lidar, camera and radar sensors exhibit a significant message size and hence data rate reduction when moving from raw to processed data (above 97%). This is the case because raw data consists of bulky pointclouds (lidar and radar) and high-resolution images (cameras) that are transmitted without any prior compression, whereas processed data consists of the outcome of the pointcloud-based and yolo-based object detection algorithms, i.e., a list of detected objects and Regions of Interest (RoI), respectively. Note that detected objects in our scenarios refer to other vehicles surrounding the ego vehicle. Detected objects and RoIs exhibit a significantly smaller payload or message size, and therefore average data rate, with respect to raw data as they are compactly represented by 2D points or bounding boxes with specific distance, dimension, and classification attributes. On the other hand, moving from raw to processed data entails a small reduction and an increase in the average data rate in the case of the IMU and GNSS sensors. Inside the IMU corrector node (see Figure 46), the IMU raw data undergoes a correction and denoising process that does not alter the raw data input format. For this reason, IMU raw and processed sensor data exhibit similar size and average data rate characteristics. Autoware processes the raw GNSS data to extract multiple GNSS-based information, e.g., the vehicle position and orientation, and to determine the measurement uncertainty, leading to an increase in the processed data size and a corresponding increase in the average data rate.

Current trends in IVN and E/E architectures (see Section 5.3) are open to the possibilities of an increased centralization with simpler sensors generating raw data, and to the option that specific algorithms are used for data processing within sensors so that they transmit processed data. The characterization of the raw and processed data generated by the vehicle-mounted sensors is of high relevance in 6G-SHINE for exploring and designing the IVN sub-networks to support these two approaches.

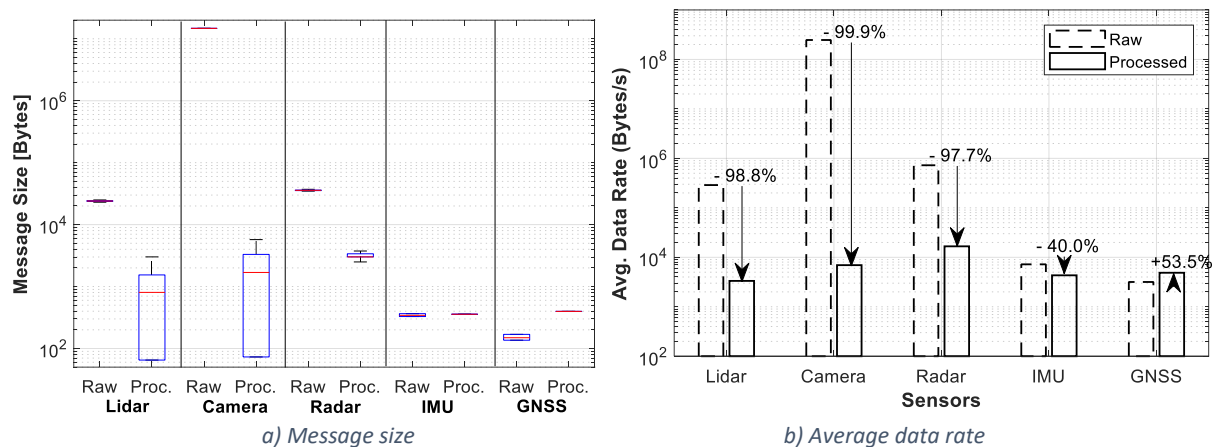

Figure 48: Raw and processed data generated by different on-board sensor types.

In line with this need for characterizing the (raw/processed) data generated by vehicle-mounted sensors, Figure 49 displays the message size of the processed radar data, i.e., the output of the Autoware's node that performs the pointcloud-based object detection (see Figure 46). Note that the message size of the processed radar data depends on the number of detected objects and that each box plot reports the median value (red line), the 25% and 75% percentiles (blue box), and the minimum and maximum values (black whiskers). Figure 49 shows that radars located in the rear bumper (R4 and R5) exhibit a smaller size, i.e., a lower number of detected objects, with respect to radar sensors mounted

on the front bumper (R1, R2, and R3). This is the case since, in the urban medium density scenario, the ego-vehicle is followed by another vehicle that impairs the Field of View (FoV) of the rear bumper sensors (see Figure 47). On the other hand, the vehicle in front of the ego-vehicle drives faster, therefore freeing the FoV of the front bumper sensors and allowing the detection of more objects/vehicles. This figure also shows that, among radar sensors mounted on the same bumper, radars mounted on the right side of the vehicle exhibit a smaller message size. On the front bumper, front-right radar (R3) is characterized by a smaller message size than front-centre (R1) and front-left (R2) radars. On the rear bumper, rear-right radar (R5) exhibits a smaller size than rear-left radar (R4). In the urban scenario, radars mounted on the right side of the vehicle cover the ego-vehicle lane and the sidewalk, where there are no surrounding vehicles. Instead, central and left-hand side radars cover both the ego-vehicle lane and the opposite lane (populated by vehicles) and, therefore, can detect a larger number of objects with respect to right-hand side radars.

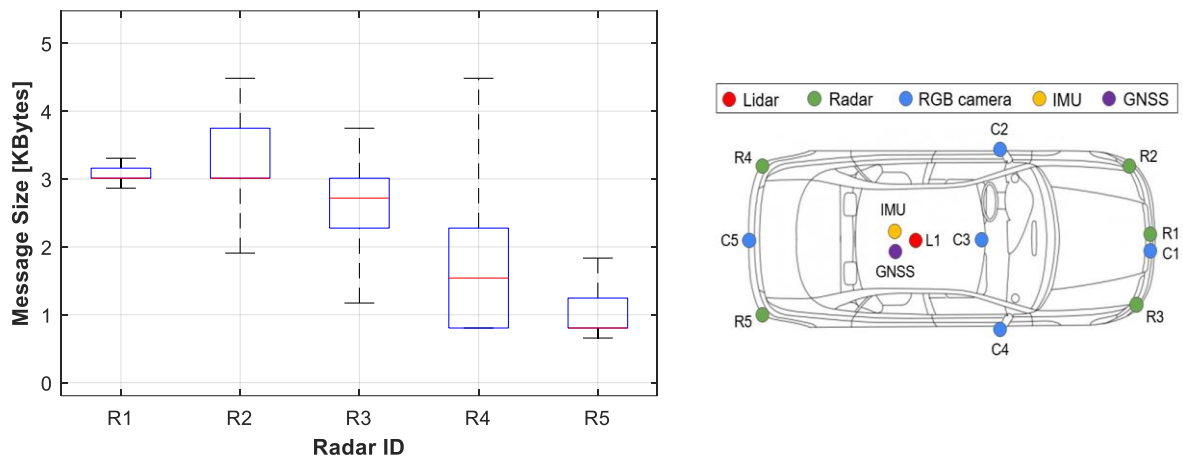

Figure 49: Size of the radars' processed data.

Figure 50 analyses the message size measured at the output of the perception module (see '/perception/object_recognition/objects' message in Figure 46) in the three driving scenarios and considering three different vehicular densities, namely, empty, low, and medium. The empty vehicular density refers to the driving condition where the ego-vehicle is surrounded by no other vehicle, and it represents a reference configuration for our analysis. The output message provided by the perception module contains the final list of detected objects, generated as a result of the object detection, sensor fusion, and trajectory estimation algorithms, and is particularly relevant as it feeds the planning module and influences the ego-vehicle's planned trajectory.

Figure 50 reveals that the driving scenario and, in particular, the vehicular density, have a strong impact on the size of the perception module's output message. As expected, Figure 50 shows that, for a given driving scenario, an increase in the vehicular density leads to an increase in the number of objects detected by – at least one of – the ego-vehicle sensors (lidar, camera, and radar) and, ultimately, to an increase in the message size. It is worth highlighting that, in the highway scenario, the impact of the vehicular density is the smallest, particularly when the transition from low to medium density is

examined. This is the case because, in the highway scenario, the ego-vehicle's sensors FoV is blocked by the preceding and following vehicles, hence obstructing the ego-vehicle's 360° view of the surrounding environment and limiting the number of objects that can be detected also in case of larger vehicular densities. With respect to the highway case, the urban and intersection are characterized by more dynamic interactions among the surrounding vehicles and the ego-vehicle. In particular, the ego-vehicle's front view is never blocked by another vehicle and, therefore, the ego-vehicle is able to detect a larger number of objects/vehicles as the vehicular density increases. In Figure 50, this is clearly reflected by the increasing values of message size obtained for increasing vehicular densities.

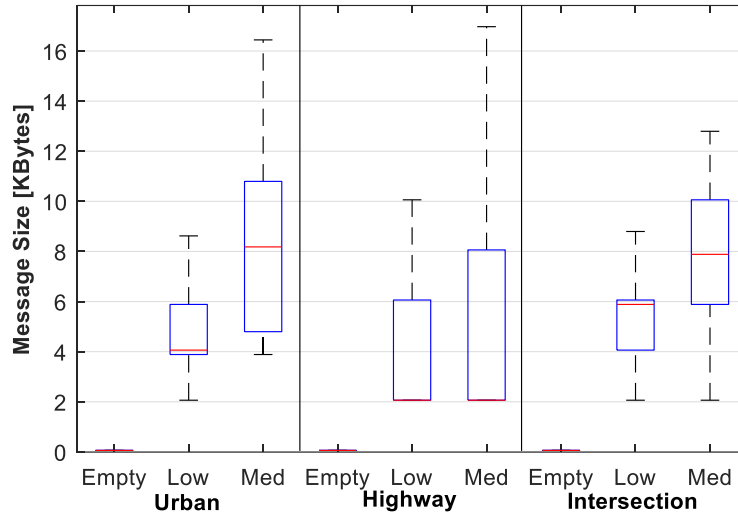

Figure 50: Message size at the output of the Autoware's perception module for different driving scenarios.

Figure 51 focuses on characterizing the cross-correlation among the data captured by the sensors deployed in the vehicle. This analysis is conducted in the urban scenario with medium density. We consider the cross-correlation of the sensors' processed messages (i.e. detected objects/vehicles), distinguishing between cameras (Figure 51.a), radars (Figure 51.b), and the combination of radars and cameras (Figure 51.c). The cross-correlation is computed based on the size of the sensors' processed messages, which reflect the number of objects/vehicles detected by each sensor.

Figure 51.a) plots the Spearman correlation coefficients for cameras C1-C5 (the deployment is illustrated in Figure 51.d). The Spearman correlation coefficient is a nonparametric rank correlation measure that describes how well the relationship between two variables can be described using a monotonic function. Compared to others correlation methods, Spearman correlation exhibits reduced sensitivity to outliers. Its advantage lies in not assuming linearity, making it appropriate at identifying non-linear relationships. Spearman correlation coefficient is defined in the $[-1, +1]$ interval. A value of Spearman correlation equal to +1 (-1) means that each variable is a perfectly positive (negative) monotone function of the other, i.e., that when one variable increases, the other variable increases (decreases). On the other hand, a Spearman correlation coefficient equal to zero means that there is no correlation between the examined variables. It should be noted that cameras C1-C4 are front-facing, while C5 faces rearwards. The locations and orientations of the cameras, and hence their overlapping field of view, are reflected in the higher Spearman cross-correlation coefficient (or cross-correlation coefficient) measured among C1-C4. A Spearman correlation close to 1 means that when one front-facing camera (e.g., C1) detects an

increasing number of objects, and its message size accordingly increases, also the message size of other front-facing cameras (C2-C4) increases, indicating that they detect a similar number of objects/vehicles. On the other hand, camera C5 exhibits lower cross-correlation with the other cameras due to its opposite orientation with respect to cameras C1-C4. In the considered urban scenario, the camera C5 is usually detecting the vehicle following the ego vehicle and its vision is often occluded by the detected vehicle. Cameras C1-C4 detect both the vehicle that is in front of the ego vehicle and those passing in the opposite direction.

Figure 51.b presents the Spearman correlation coefficients for the sizes of the radars’ processed messages (i.e. detected objects/vehicles). As shown in Figure 51.d), radars R1-R3 face forwards, while radars R4-R5 face backwards. The cross-correlation depicted in Figure 51.b reflects this orientation grouping, with high cross-correlation observed between radars R1-R3 and R4-R5, and low cross-correlations between front-facing and rear-facing radars.

Finally, Figure 51.c) shows the Spearman correlation coefficients when comparing the sizes of the radar and cameras’ processed messages. Figure 51.c) reveals the exiting correlation (despite being different sensor types) between the sizes of these messages (i.e. the detected objects/vehicles) by front-facing sensors, i.e., radars R1-R3 and cameras C1-C4, and the lower correlation between front-facing radars R1-R3 and rear-facing camera C5.

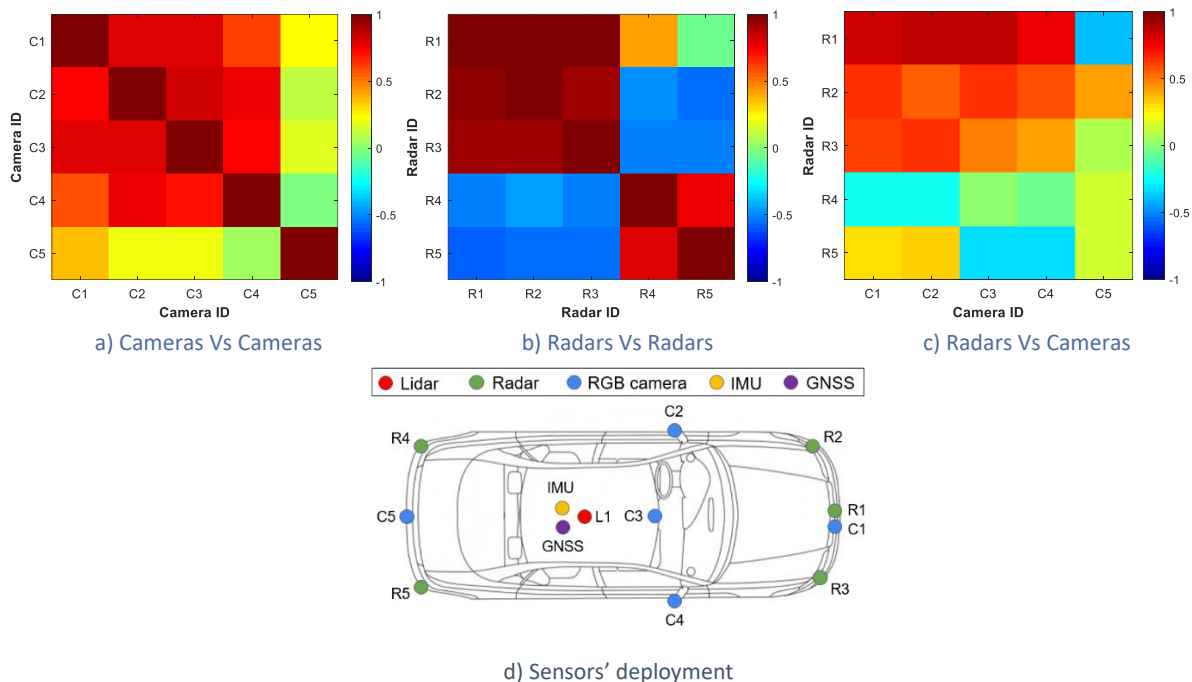

Figure 51: Cross-correlation between the sensors’ processed data.

We analyse in Figure 52 the cross-correlation between processed data (i.e. detected objects/vehicles) of radars as a function of the simulation time. The analysis focuses on the urban scenario where there are vehicles driving in opposite directions. Figure 52 shows the Spearman correlation coefficients between the front-centre radar (R1) and all other radars (R2-R5). Spearman’s correlation has been

computed considering a sliding window of 5 seconds (i.e. 100 radar samples). The selected simulation period in Figure 52 (from time instant 20s to 40s) captures the moment when a vehicle driving in the opposite direction approaches and then passes by the ego vehicle. The obtained results show an increasing cross-correlation between the front bumpers radars (i.e. between radars R1 and R2, and between R1 and R3) as the vehicle driving in the opposite direction approaches and is detected by the ego vehicle. The opposite trend is observed between the front radar R1 and rear radars R4 and R5. The data captured in Figure 52 shows also a relevant difference between the cross-correlation between radars R1 and R2, and between R1 and R3. At time instant 30s, the vehicle driving in the opposite direction is no longer detected by the front right radar R3, as its FoV is concentrated on the sidewalk and partially covers the opposite lane, while it remains in the field of view of the front-centre and front-left radars (R1 and R2). This is reflected in the decreasing correlation coefficients between radars R1 and R3 from time instant 30s, while the correlation coefficients between R1 and R2 remain high until time instant 35s. At this time, the vehicle driving in the opposite direction passes by and exits the field of view of the front-centre (R1) and front-left (R2) radars, and therefore the cross-correlation coefficient between R1 and R2 decreases. Figure 52 serves as an example to illustrate the multiple possible correlations over time that can characterize the data generated and processed by the different sensors mounted on the vehicle. In the framework of the 6G-SHINE project, the characterization of these correlation patterns can be exploited to anticipate in-vehicle subnetworks traffic flows and reconfigure the subnetworks for deterministic service provisioning.

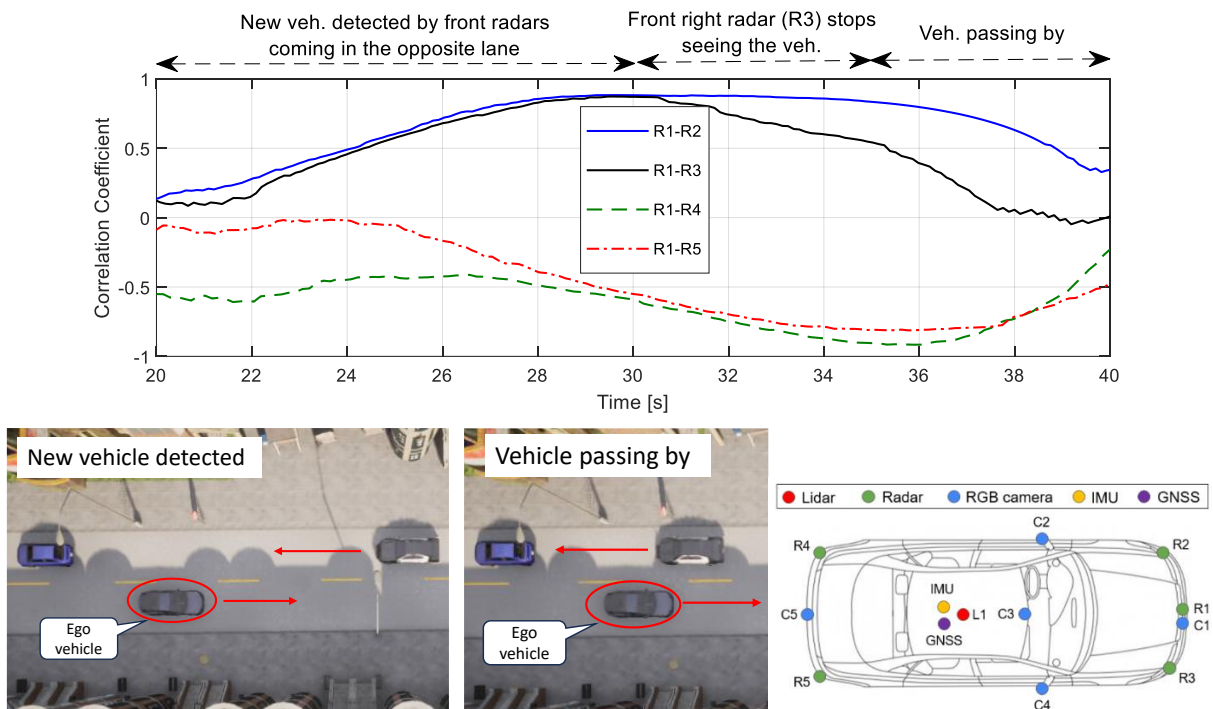

Figure 52: Cross-correlation of the processed message sizes of the radars over time.

Finally, we analyse in Figure 53 the processing time of Autoware's perception module. This module is of high importance for the vehicles' autonomous driving operation since it serves as an intermediary between the in-vehicle sensors and the trajectory planner. In future centralized, zone-oriented E/E

architectures, such as the one being considered as a reference for the 6G-SHINE in-vehicle subnetwork use cases (see Section 5.3), the operations of the perception and planning modules are expected to be executed in separate dedicated nodes or platforms, namely the ADAS integration platform and the motion integrated platform [44]. The characterization of the perception module’s processing time is hence of interest to anticipate or predict the need for transmission resources at the output of the perception module triggered by new incoming sensor data. As an example of the CAM platform - and the generated in-vehicle traces - potential for the characterization of in-vehicle traffic, Figure 53 shows the CDF of the time required by the perception module to process the input raw sensors data. The processing inside the perception module includes the detection and localization of surrounding objects on the digital map available in the vehicle, the estimation of the trajectory of each detected object, and, finally, the generation of an output message that is passed to the planning module.

The results reported in Figure 53 have been normalized to eliminate the dependencies of the computer’s resources utilized to execute the CAM platform and the measured perception processing times. Although further analysis will be performed within 6G-SHINE’s WP3 and WP4, Figure 53 shows that the perception processing time is far from being deterministic and exhibits significant variations. The “step-wise” trend exhibited by the CDF suggests that there may be some states in the perception module that trigger discrete processing times. Identifying the conditions that cause and rule these states in the internal operation of the perception module would help contribute towards the predictability of the perception module perception time.

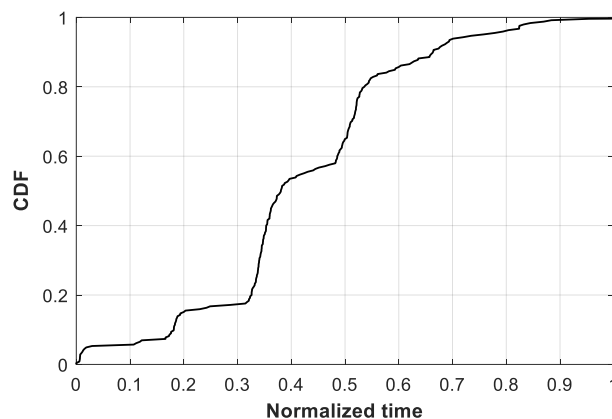

Figure 53: Perception module’s processing time

5.8 6G CHALLENGES AND 6G-SHINE TECHNOLOGY COMPONENTS RELATED TO IN-VEHICLE SUBNETWORK

The in-vehicle networks will need to support a growing number of automotive applications with varying requirements that require interconnecting cross-domain functions and collaboration between sensors and actuators physically located in different zones of the vehicle. These are raising demands on in-vehicle networks with high bandwidth data flows and lower and deterministic latency requirements. The demands will significantly increase with the softwarization of vehicles and the gradual introduction of AD functions. This challenges the integration of 6G wireless technologies in vehicles to replace cable-based connections used in time-safety critical automotive systems. The stochastic nature of wireless communications makes it difficult to achieve time-critical and strict service level capabilities (e.g., determinism/TSN) that are interoperable and compatible with wired capabilities.

The evolution of in-vehicle networks is directly related to the rising demands of increasingly sophisticated automotive applications. These applications would require in-vehicle wireless networks capable of handling high-bandwidth data flows and lower, deterministic latency requirements. The ongoing trend of vehicle softwarization and the gradual integration of AD functions are expected to significantly amplify these demands.

The following 6G-SHINE’s Technology Components (TCs) are identified as relevant to address the above challenges, see Table 32.

Note: We do not intend to evaluate all the following TCs for a given use case in the other technical WPs. The TCs will be evaluated for specific selected use cases, and eventually it may be elaborated on how these TCs can also be used in the other use cases.

Table 32: Technical Components (TCs) addressing In-Vehicle category use case challenges

Technology component (TC)	Use cases	Explanation
TC1. In-X data traffic models	<ul style="list-style-type: none"> • Wireless Zone ECU • Collaborative Wireless Zone ECU 	In-vehicle data traffic generated by sensors (e.g., camera, lidar, radar, etc.) in a zone and between zones will be collected from an emulation platform for its characterization (e.g., spatial-temporal correlations) and for determining its requirements.
TC2. Channel models for in-X scenarios	<ul style="list-style-type: none"> • Wireless Zone ECU • Collaborative Wireless Zone ECU • Inter-subnetwork Coordination • Virtual ECU 	In-vehicle channel model will be derived based on radio propagation measurements inside vehicles. Measurements will also cover propagation from outside to inside the vehicle. The use of RIS could also be covered in the measurement campaign.
TC3. Sub-THz system models	<ul style="list-style-type: none"> • Wireless Zone ECU • Collaborative Wireless Zone ECU 	The in-vehicle subnetwork wireless link can benefit from the high-bandwidth, reliable, and low latency sub-THz communications.
TC4. Ultra-short transmissions with extreme reliability	<ul style="list-style-type: none"> • Wireless Zone ECU 	Critical sensors generating non-predictable traffic composed of short packets require ultra-reliable transmissions.
TC5. Analog/hybrid beamforming/beam-focusing	<ul style="list-style-type: none"> • Wireless Zone ECU 	TC.5 might be necessary to support TC.4
TC6. Jamming-aware native PHY design	<ul style="list-style-type: none"> • Wireless Zone ECU • Collaborative Wireless Zone ECU 	Native robustness to jamming attacks is needed for life-critical in-vehicle services.

	<ul style="list-style-type: none"> • Inter-subnetwork Coordination • Virtual ECU 	
TC7. RIS enhancements	<ul style="list-style-type: none"> • Wireless Zone ECU • Collaborative Wireless Zone ECU • Inter-subnetwork Coordination 	Static smart surfaces deployed within the vehicle can create a favourable propagation condition to reduce interference and improve the links' reliability.
TC8. Intra-subnetwork macro-diversity	<ul style="list-style-type: none"> • Collaborative Wireless Zone ECU 	The possibility that the sensors can connect directly to the HPCU brings some macro diversity possibilities, such that the zone ECU can act as a relay, or provide a redundant radio link to the HPCU.
TC9. Flexible/full duplex scheduler	<ul style="list-style-type: none"> • Wireless Zone ECU • Collaborative Wireless Zone ECU 	Flexible/full duplexing capabilities at the AP or zone ECU are of high relevance to multiplex traffic with different requirements from different automotive systems
TC10. Predictive scheduler	<ul style="list-style-type: none"> • Wireless Zone ECU • Collaborative Wireless Zone ECU 	The localized and predictive nature of the traffic patterns generated and demanded in the in-vehicle zone by sensors/actuators can be exploited to anticipate radio resource requests and program scheduling. Traffic prediction can also be utilized to pre-allocate resources in the communication path between subnetworks located at different in-vehicle zones, which can be particularly necessary for use cases and links requiring deterministic service levels.
TC11. Latency-aware access in the unlicensed spectrum	<ul style="list-style-type: none"> • Wireless Zone ECU • Collaborative Wireless Zone ECU • Inter-subnetwork Coordination 	In-vehicle wireless subnetworks might operate using licensed or unlicensed spectrum.
TC12. Centralized radio resource management	<ul style="list-style-type: none"> • Inter-subnetwork Coordination 	The integration of 6G in-vehicle networks with the 6G parent network favours the centralized management of radio resources to prevent intra-/inter-vehicle subnetworks interferences.
TC13. Distributed/hybrid radio resource management	<ul style="list-style-type: none"> • Inter-subnetwork Coordination 	Distributed/hybrid radio resource management schemes will be critical for preventing interference among in-vehicle

		subnetworks at nearby vehicles, in particular when experiencing partial coverage from a 6G parent network or critical functions that might require short reaction times to prevent interference.
TC14. Jamming detection and mitigation	<ul style="list-style-type: none"> • Wireless Zone ECU • Collaborative Wireless Zone ECU • Inter-subnetwork Coordination • Virtual ECU 	Native robustness to jamming attacks is needed for life-critical in-vehicle services.
TC15. Hybrid management of traffic, spectrum and computational resources	<ul style="list-style-type: none"> • Virtual ECU 	6G-SHINE will explore solutions for efficient and dynamic traffic and computational offload between subnetworks and the larger 6G network.
TC16. Coordination of operations among subnetworks in the same entity	<ul style="list-style-type: none"> • Collaborative Wireless Zone ECU 	Adaptive and efficient coordination mechanisms within and across subnetworks will be designed for dependable service levels in-vehicle networks and offloading computational tasks among HCPUs or ECUs when needed or beneficial.

6 CONCLUSIONS

This deliverable discussed the use cases and service requirements of the identified 6G-SHINE subnetwork categories, namely commercial, industrial, and in-vehicle subnetwork category. We have identified 13 use cases in three categories. The consumer subnetwork category has 4 use cases in which the use cases are representing different purposes and applications, such as education, gaming, and navigation. There are 5 and 4 use cases for the industry and in-vehicle subnetwork categories, respectively. In these categories, the use cases are identified with a different approach than the consumer subnetwork. The use cases are represented using a bottom-up approach, starting from the subnetwork in a single entity or zone to a complex one that consists of multiple entities or zones. The use cases titles and short descriptions are provided in Table 33.

Table 33: Summary of the use cases and short descriptions

No	Title	Short Descriptions
C-1	Immersive Education	Immersive Education aims to enhance the interactive experience for a group of students and teacher(s) for knowledge exchange, leveraging media content and related technologies (e.g., XR devices).
C-2	Indoor Interactive Games	XR interactive gaming in an indoor environment where one or more players play in a place where it has been equipped and pre-loaded with some equipment to facilitate the XR interactive gaming.
C-3	Virtual Live Production	One or more performers that can be located in different geographical areas produce 3D video content that can be live-broadcasted or uploaded to social media.
C-4	AR Navigation	AR navigation powered by AI/ML concierge based on user input, including the information around the user. The output is provided to the user via an AR device.
I-1	Robot Control	The wireless control of robot operations, such as the control of multi-axis robots for leveraging the degrees of freedom offered by potential movement directions the robot can accomplish.
I-2	Unit Test Cell	To perform quality assurance tasks of product parts in the manufacturing process, as well as of devices used in the manufacturing process.
I-3	Visual Inspection Cell	A visual inspection cell performs quality assurance in the manufacturing process through video feeds. The video feeds are processed, and quality control is performed, by eventually outputting commands to actuators in case actions are to be taken for improving operation quality.
I-4	Subnet Co-existence in Factory Hall	Tasks distributions among a swarm of smaller, specialized robots. Each robot is configured to perform a

		specific function. Working in concert, these robotic swarms can assemble intricate products
I-5	Subnetwork Segmentation and Management	Combination of all the other industrial use cases with a focus on the security and management aspects, particularly on functional requirements.
V-1	Wireless Zone ECU: in-vehicle wireless subnetwork zone	In-vehicle zone wireless subnetwork that is utilized by some sensors and actuators located in this zone to connect wirelessly to the zone ECU that manages and controls them. The sensors and actuators that are wirelessly connected to the zone ECU are equipped with a 6G-capable wireless communication interface that replaces their former wired communication interface.
V-2	Collaborative Wireless Zone ECUs: Functions across multiple in-vehicle zones	This use case covers automotive systems and applications that require (or benefit from) collaboration or offloading between functions, sensors and actuators located at different zones of the considered 6G-SHINE reference in-vehicle E/E architecture.
V-3	Inter-subnetwork Coordination: Collaboration/interference/RRM between subnetworks in intra/inter-vehicle communications	Two cases of subnetwork coordination on RRM/interference handling where the sub-networks can be within the same vehicle (Intra-vehicular) or in some other vehicle(s) (Inter-vehicular).
V-4	Virtual ECU: In-vehicle sensor data and functions processing at the 6G network edge	Integrating the in-vehicle network with the 6G parent network, to seamlessly extend the in-vehicle embedded compute capabilities to the edge/cloud.

The major characteristic of 6G-SHINE use cases is the operation of in-X subnetwork. The network elements and reference architectures are essential in describing the use cases. All of the network elements are utilized in all use cases. RIS is considered as an optional element that can be used to improve link quality, extend the coverage, and shape the interference. Some use cases may have the same network elements but performing different roles. The subnetwork architecture in each use case facilitates in identifying the communication modes between elements and the functional requirements.

The traffic characterisation in some use cases could be used later in identifying the technical solutions to solve the challenges related to 6G-SHINE use cases. Furthermore, the traffic characterisation could be used to derive the requirements of certain KPIs. The identified KPI and its requirements for various use cases have unique characteristics:

- The use cases in consumer subnetworks typically require high data rates and low latency. Computation offloading is commonly used in many use cases for video rendering purpose and AI/ML data processing. A certain level of reliability is still needed to minimize possible retransmission which may increase the latency. It has a mixture of KPIs for various links, such as one or more data streams with high data rates (UL/DL video frame) and accompanied by multiple low data rates for sensors. Furthermore, synchronization of multiple streams, such as

- video, audio, and sensors is required. It is a challenging requirement to achieve high data rates which can reach up to 6.37 Gbps with low latency and high reliability.
- The use cases in the Industrial subnetworks typically require ultra-low latency and high reliability. Ultra-low latency is required to support communication cycles with less than 100 μ s in one of the use cases. The data rate is typically low, but it may have a high number of devices connected to an AP. Furthermore, the operation of multiple APs may be needed. Hence, a proper network architecture design is required to ensure the operation of low latency and possible computation offloading from one node to another. Note that use cases where video feeds play a role can also require high data rates (i.e., up to 50 Mbps).
 - The use cases in the In-vehicle subnetwork typically require extreme reliability. Some use cases may require 99.9% reliability. The possible multiple links are a mixture of medium data rates (e.g., picture/video captured by camera) and low data rates (e.g., the interactions with sensor(s) and actuator(s)).

The use cases defined in 6G-SHINE are expected to provide key values on social, environment, and economic sustainability. In all use cases, social sustainability is achieved by improving user experience compared to the existing technology. For the environment sustainability, the aim is to reduce carbon footprint (including carbon dioxide and methane) as well as energy consumption. For the economic sustainability we can consider production efficiency improvements in the industry subnetwork category, increasing the vehicle lifetime and circular economy promotion in the in-vehicle subnetwork category, and creating new services for game and education in the consumer subnetwork category. The benefits introduced in 6G-SHINE use cases can be associated to the KVis. Low latency and reliable communications are the KV enabler in all use cases. High data rate is required in some of the use cases, particularly in consumer subnetwork category.

It has been shown that all the 6G-SHINE technology components can be applied in some of the presented use cases. First of all, TC-1 In-X data traffic models and TC-2 channel model for the in-X scenario can be the starting point for all of the use cases. All use cases require low latency. Hence, TC4 Ultra-short transmission with extreme reliability is needed. Note that the extreme reliability is more crucial for both industry and in-vehicle subnetworks. Some of the use cases may require tailored technology components. For example, the consumer subnetwork deployed in a small room is feasible to be supported with TC3 Sub-THz system models. In another example, the industry subnetwork with multiple subnetworks is expected to require the development of TC16 on Coordination of operations among subnetworks in the same entity.

This deliverable will be used as the reference for other activities across the involved WPs of the project, such as TCs development and PoC activity. Within WP2, we will characterize radio propagation at different frequency bands to be reported in Deliverable D2.3. We will also explore detailed network architectures for in-X subnetworks of the selected identified use cases in this deliverable to be reported in Deliverable D2.4. Deliverable D2.4 will delve into architectural enhancement for in-X subnetworks, and their connection with a 6G parent network. In this respect, input from the SNS architecture working group would be of high relevance for aligning our architectural enhancements with the other SNS research in the field.

REFERENCES

- [1] 3GPP TS 22.261 V17.6.0, "Tech. Specification Group Services and System Aspects; Service requirements for the 5G system; Stage 1 (Rel. 17)", March 2021.
- [2] 3GPP TS 22.104 V17.7.0, "Service Requirements for Cyber-physical Control Applications in Vertical Domains", September 2021.
- [3] 3GPP TR 38.838 V17.0.0, "Tech. Report Group Radio Access Network; Study on XR (Extended Reality) Evaluations for NR (Rel. 17)", December 2021.
- [4] G. Wikström, A. Schuler Scott, I. Mesogiti, R.-A. Stoica, G. Georgiev, S. Barmounakis, A. Gavras, P. Demestichas, M.-H. Hamon, H.-S. Hallingby, D. Lund, (2022), "What societal values will 6G address?", Zenodo, url: <https://doi.org/10.5281/zenodo.6557534>.
- [5] United Nations, 2020, The 17 Goals, url: <https://sdgs.un.org/goals>
- [6] United Nations, 2023, What are the Sustainable Development Goals?, url: <https://www.undp.org/sustainable-development-goals>
- [7] Stockholm Resilience Center, url: <https://www.stockholmresilience.org/research/research-news/2017-02-28-contributions-to-agenda-2030.html>
- [8] European Association of Research & Technology Organisations, "[The TRL Scale as a Research & Innovation Policy Tool, EARTO Recommendations](#)" (PDF), 30 April 2014.
- [9] Northey, Stephen, Nawshad Haque, and Gavin Mudd, "Using sustainability reporting to assess the environmental footprint of copper mining", *Journal of Cleaner Production* 40 (2013): 118-128.
- [10] E. Basar, M. Di Renzo, J. De Rosny, M. Debbah, M. -S. Alouini and R. Zhang, "Wireless Communications Through Reconfigurable Intelligent Surfaces," in *IEEE Access*, vol. 7, pp. 116753-116773, 2019, doi: 10.1109/ACCESS.2019.2935192.
- [11] Berardinelli et al., "Extreme Communication in 6G: Vision and Challenges for 'in-X' Subnetworks", *IEEE Open Journal of the Communications Society*, vol. 2, pp. 2516 - 2535, 2021.
- [12] "Education and training in the EU - facts and figures", available online: https://ec.europa.eu/eurostat/statistics-explained/index.php?title=Education_and_training_in_the_EU_-_facts_and_figures
- [13] 3GPP TR 26.926 V18.1.0, "Tech. Specification Group Services and System Aspects; Traffic Models and Quality Evaluation Methods for Media and XR Services in 5G Systems (Release 18)", December 2023.
- [14] 3GPP TR 26.928 V18.0.0, "Tech. Specification Group Services and System Aspects; Extended Reality (XR) in 5G (Release 18)", March 2023.
- [15] 3GPP TR 38.901 V17.1.0, "Tech. Specification Group Radio Access Network ; Study on channel model for frequencies from 0.5 to 100 GHz".
- [16] 3GPP TR 22.847 V18.2.0, "Tech. Specification Group Services and System Aspects; Study on supporting tactile and multi-modality communication services" March 2022.
- [17] 3GPP Newsletter, "eXtended Reality for NR", Issue 06, November 2023.
- [18] Preparing for a cloud AR/VR future", Huawei, <https://www.huawei.com/en/huaweitech/industry-insights/outlook/mobile-broadband/xlabs/insights-whitepapers/cloud-vr-ar-white-paper>
- [19] F. Hu, Y. Deng, W. Saad, M. Bennis and A. H. Aghvami, "Cellular-Connected Wireless Virtual Reality: Requirements, Challenges, and Solutions," in *IEEE Communications Magazine*, vol. 58, no. 5, pp. 105-111, May 2020, doi: 10.1109/MCOM.001.1900511

- [20] 3GPP TS 22.827 V17.1.0, “Technical Specification Group Services and System Aspects; Study on Audio-Visual Service Production”, December 2019.
- [21] PREDICT-6G, D1.1, “Analysis of use cases and system requirements”, June 2023.
- [22] DETERMINISTIC-6G, D1.1, “Analysis of use cases and system requirements”, June 2023.
- [23] Mahmood, Aamir, et al., Factory 5G: “A review of industry-centric features and deployment options”, IEEE Industrial Electronics Magazine 16.2 (2022): 24-34.
- [24] Rodriguez, Ignacio, et al., “5G swarm production: Advanced industrial manufacturing concepts enabled by wireless automation”, IEEE Communications Magazine 59.1 (2021): 48-54.
- [25] Bányai, Tamás. "Optimization of material supply in smart manufacturing environment: A metaheuristic approach for matrix production." Machines 9.10 (2021): 220.
- [26] 3GPP TR 22.804 V16.3.0, “Tech. Specification Group Services and System Aspects; Study on Communication for Automation in Vertical Domains (Release 16)”, July 2020.
- [27] R. S. Mogensen, I. Rodriguez, G. Berardinelli, G. Pocovi, T. Kolding, “Empirical IIoT data traffic analysis and comparison to 3GPP 5G models”, 2021 IEEE 94th Vehicular Technology Conference (VTC2021-Fall), pp. 1-7. IEEE, 2021.
- [28] 5G Alliance for Connected Industries and Automation, “Key 5G Use Cases and Requirements”, 5G-ACIA White Paper, May 2020.
- [29] Adeogun, Ramoni, et al., “Towards 6G in-X subnetworks with sub-millisecond communication cycles and extreme reliability”, IEEE Access 8 (2020): 110172-110188.
- [30] International Electrotechnical Commission (IEC) 62443:
<https://webstore.iec.ch/searchform&q=IEC%2062443> [last accessed in July 2023].
- [31] Gündüz et al., “Beyond Transmitting Bits: Context, Semantics, and Task-Oriented Communications”, IEEE Journal on Selected Areas in Communications, vol. 41, no. 1, pp. 5-41, Jan. 2023.
- [32] 5G-ACIA white paper: A 5G Traffic Model for Industrial Use Cases, November 2019
- [33] TIMES, Deliverable D2.1, “Definition of use cases, KPIs, and scenarios for channel measurements”, June 2023.
- [34] PREDICT-6G, <https://predict-6g.eu/>
- [35] DETERMINISTIC-6G, <https://deterministic6g.eu/>
- [36] Hexa-X-II, Deliverable D 1.2 “6G Use Cases and Requirements”, December 2023.
- [37] 3GPP TS 23.501 V18.0.0 “Tech. Specification Group Services and System Aspects: System architecture for the 5G System (5GS)”, December 2023.
- [38] E. Lisova, R. Broux, J. Denil, A. Bucaioni, S. Mubeen, “Communication Patterns for Evaluating Vehicular E/E Architectures”, 2022 International Conference on Electrical, Computer, Communications and Mechatronics Engineering (ICECCME), Maldives, Maldives, 2022, pp. 1-8, doi: 10.1109/ICECCME55909.2022.9987747.
- [39] A. G. Mariño, F. Fons, J. M. M. Arostegui, “The Future Roadmap of In-Vehicle Network Processing: A HW-Centric (R-)evolution”, IEEE Access, vol. 10, pp. 69223-69249, 2022, doi: 10.1109/ACCESS.2022.3186708.
- [40] H. Askaripoor, M. Hashemi Farzaneh, A. Knoll, “E/E Architecture Synthesis: Challenges and Technologies”, Electronics, vol. 11, no. 4, p. 518, Feb. 2022, doi: 10.3390/electronics11040518.
- [41] Bosch’s presentation in ASAM, “E/E-Architecture in a Connected World”, March 2017. Available online at [last accessed in July 2023]:
<https://www.asam.net/index.php?eID=dumpFile&t=f&f=798&token=148b5052945a466cacfe8f31c44eb22509d5aad1>
- [42] P. Aberl, S. Haas, A. Vmuri, “How a Zone Architecture Paves the Way to a Fully Software-Defined Vehicle”, Texas Instrument White Paper, April 2023.

- [43]V. Bandur, G. Selim, V. Pantelic, M. Lawford, “Making the Case for Centralized Automotive E/E Architectures”, IEEE Transactions on Vehicular Technology, vol. 70, no. 2, pp. 1230-1245, Feb. 2021, doi: 10.1109/TVT.2021.3054934.
- [44]Bosch Mobility, official web page [last accessed in July 2023]: <https://www.bosch-mobility.com/en/mobility-topics/ee-architecture/>
- [45]IEEE P802.1DG – TSN Profile for Automotive In-Vehicle Ethernet Communications [last accessed in July 2023]: <https://1.ieee802.org/tsn/802-1dg/>
- [46]V. M. Navale, K. Williams, A. Lagospiris, M. Schaffert, M.-A. Schweiker, “(R)evolution of E/E architectures”, SAE Int. J. Passenger Cars-Electron. Elect. Syst., vol. 8, no. 2, pp. 282–288, 2015.
- [47]W. Zeng, M. A. S. Khalid, S. Chowdhury, “In-Vehicle Networks Outlook: Achievements and Challenges”, IEEE Communications Surveys & Tutorials, vol. 18, no. 3, pp. 1552-1571, Sept. 2016.
- [48]“The changing automotive industry landscape”, EE World Resource, April 2022.